

BUTTERFLY VALVE

GATE VALVE

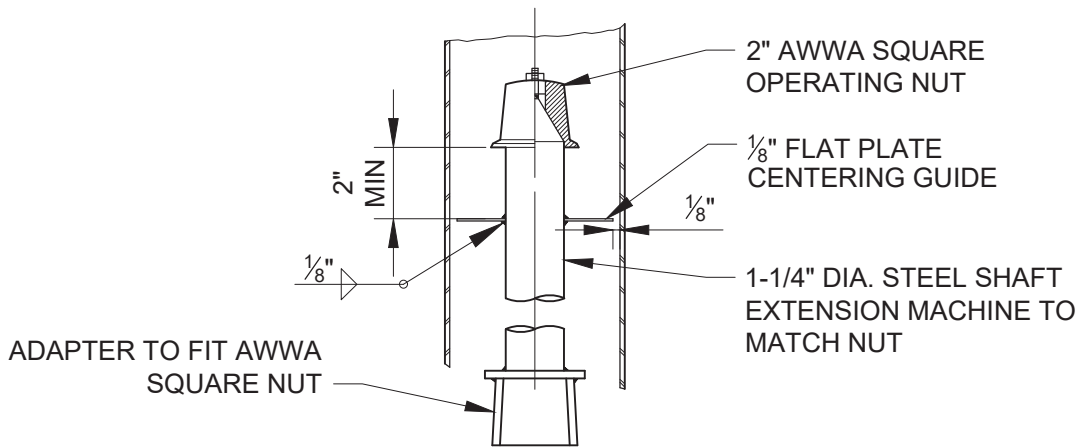

VALVE STEM EXTENSION

NOTES:

1. VALVE STEM EXTENSIONS ARE ONLY TO BE USED WHEN THE VALVE IS GREATER THAN 8' DEEP
2. REFER TO STD. PLAN 570 S FOR LEGEND ITEMS, APPROVED PARTS LIST, AND DETAIL NOTES.

| | | | |
|---|---------|---------------------------------------|------------|
| PARK CITY MUNICIPAL CORPORATION WATER | DATE | BURIED VALVE AND VALVE BOX | STD. PLAN |
| | 03/2024 | | 570 |
| | REV. | | |
| | 1 | | |

LEGEND AND APPROVED PARTS LIST

| ITEM | DESCRIPTION | ACCEPTABLE MANUFACTURER | MODELS |
|------|--|-----------------------------|---|
| ① | BUTTERFLY VALVE, NRS, AWWA C504 CLASS 250B, 250 PSI, SST BONNET BOLTS, FLANGED END CONNECTIONS | MUELLER | LINESEAL XP11, 5227 SERIES OR APPROVED EQUAL |
| ② | GATE VALVE, NRS, AWWA C509, 250 PSI, SST BONNET BOLTS, END CONNECTIONS PER FOLLOWING: ON TEES: FLG x FLG IN-LINE VALVES: MJ x MJ OTHERS: MJ x MJ, OR PER DESIGN | MUELLER | SERIES 2360 OR APPROVED EQUAL |
| ③ | POLYETHYLENE ENCASEMENT, HIGH DENSITY CROSS LAMINATED (HDCL) POLYETHYLENE FILM, AWWA C105 & AWWA C703E METHOD C | CHRISTY'S OR APPROVED EQUAL | AWWA C703E METHOD C (4 MIL) |
| ④ | VALVE BOX, CAST IRON, TWO PIECE, SLIP TYPE WITH CAST IRON DROP-IN COVER MARKED AS FOLLOWS: ISOLATION VALVE: "WATER" BUTTERFLY VALVE: "BFV" IRRIGATION: "IRRIG" FIRE LINE VALVE: "FIRE" VALVE BOX RISER: LIMIT ONE PER VALVE BOX | D&L SUPPLY OR APPV'D EQUAL | BOX AND LID: M-8042 RISER: M-8049 THRU M-8055 EXTENSION: M-8070 |

DETAIL NOTES

1. VALVES TO BE RATED FOR WORKING AND TEST PRESSURE OF WATER MAIN
2. PROVIDE FUSION BONDED EPOXY COATING ON GATE VALVE AND BUTTERFLY VALVE INTERIOR AND EXTERIOR
3. PROVIDE 316 SST BOLTS AND NUTS WITH ANTI-SEIZE LUBRICANT ON FLANGED CONNECTIONS
4. DO NOT LOCATE VALVE AND VALVE BOX WITHIN CURB OR GUTTER
5. CENTER VALVE BOX ON VALVE OPERATING NUT
6. SET VALVE BOX PLUMB WITHOUT DEFLECTIONS IN VALVE BOX JOINTS
7. PROVIDE ADDITIONAL SLIP BASE FOR VALVE BOX ON 7' BURY WATER MAIN
8. APPLY WAX TAPE COATING SYSTEM TO VALVE BONNET BOLTS AND ALL OTHER BURIED BOLTS AND NUTS, AWWA C217. SYSTEM TO INCLUDE FILLER MATERIAL, TAPE COATING, AND PROTECTIVE OUTERWRAP. DENSO NORTH AMERICA, TRENTON, OR APPROVED EQUAL (STD. PLAN 534)

| | | | |
|--|-------------|--|-----------------------------------|
|  PARK CITY MUNICIPAL CORPORATION WATER | DATE | <h2 style="margin: 0;">BURIED VALVE AND VALVE BOX</h2> | STD. PLAN |
| | 02/2024 | | <h1 style="margin: 0;">570 S</h1> |
| | REV. | | |
| | 1 | | |

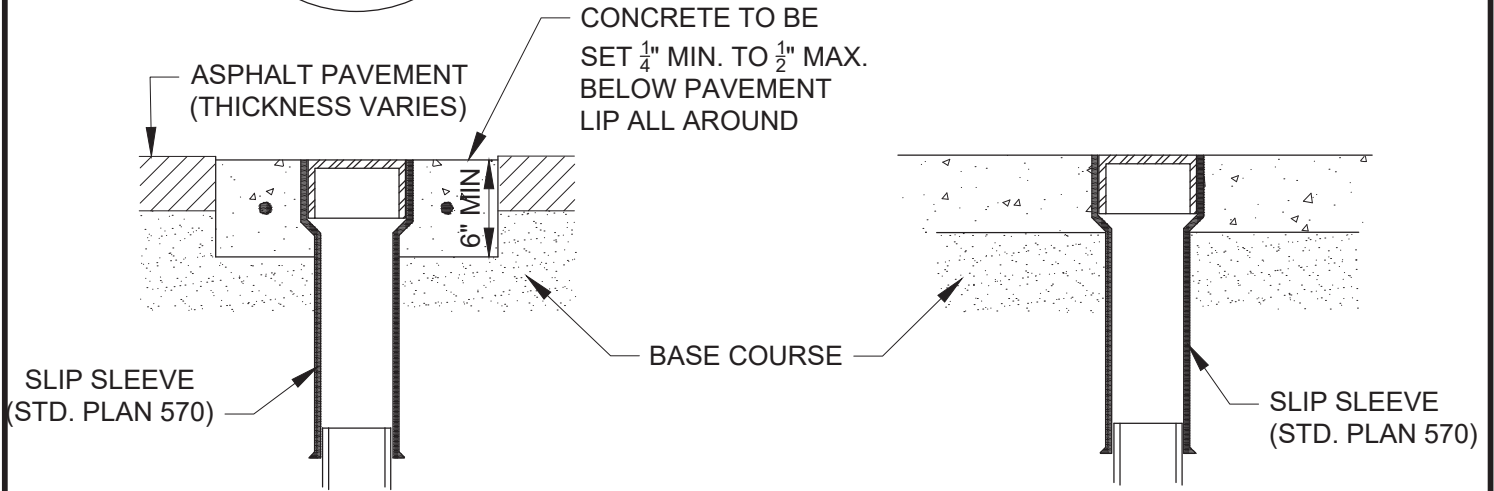
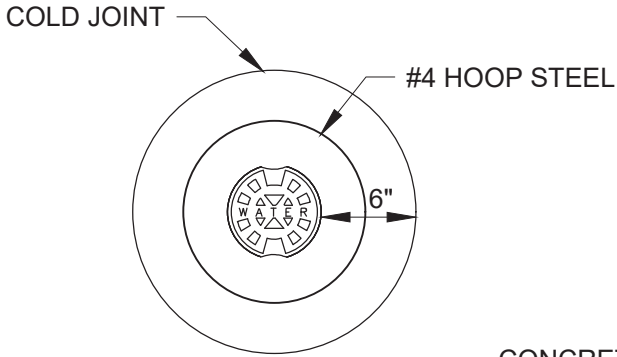

ASPHALT PAVEMENT

CONCRETE PAVEMENT

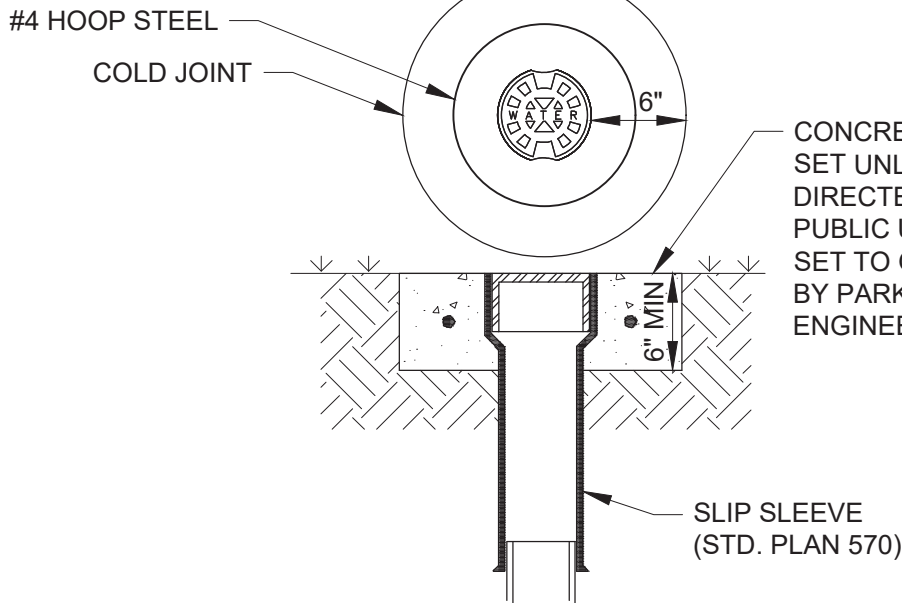

LANDSCAPED AREA



PARK CITY MUNICIPAL CORPORATION
WATER

DATE

3/2024

REV.

1

**VALVE BOX
COLLAR**

STD. PLAN

572

GENERAL NOTES

1. ALL WORK SHALL CONFORM TO PARK CITY DESIGN STANDARDS, CONSTRUCTION SPECIFICATIONS, AND STANDARD DRAWINGS.
2. SUBMIT SHOP DRAWINGS TO DESIGN ENGINEER AND CITY ENGINEER FOR APPROVAL PRIOR TO CONSTRUCTION. INCLUDE MECHANICAL, STRUCTURAL, ELECTRICAL AND INSTRUMENT DRAWINGS IDENTIFYING CONDUIT, CONDUCTOR, CABLE, SIZE AND ROUTINGS FOR POWER, GROUNDING, INSTRUMENTATION, AND CONTROLS, OPENINGS, PIPE, VALVES, HATCH, AND ALL VAULT COMPONENTS.
3. VAULT BACKFILL: STRUCTURAL FILL MATERIAL COMPACTED TO 95% MINIMUM OF MODIFIED PROCTOR DENSITY.
4. DUCTILE IRON PIPE, FITTINGS, COUPLERS, FLANGES, ETC. SHALL BE IN ACCORDANCE WITH AWWA C153, C111, AND C110 AND RATED FOR A MINIMUM 250 PSI WORKING PRESSURE.
5. FLANGED JOINTS: 125 LB FLANGES, ANSI/AWWA C115/A21.15. "FULL FACE FLANGE-TYTE" GASKET OR "RING FLANGE-TYTE" GASKET (OR PRE-APPROVED EQUAL). GASKETS TO BE HIGH-PERFORMANCE TYPE, 1/8" THICK, AND HAVE AT LEAST (3) BULB TYPE RINGS MOLDED INTO BOTH GASKET FACES, ANSI/AWWA C110/A21.11.
6. FITTINGS: FULL BODY AWWA C110. NO COMPACT FITTINGS. DOMESTIC "MADE IN USA".
7. DUCTILE IRON PIPE AND FITTINGS: UNCOATED. PRIME AND PAINT WITH NSF APPROVED HIGH SOLIDS EPOXY PAINT, TNE MEC POTA-POX N140 OR PRE-APPROVED EQUAL. HIGH PRESSURE SIDE, LIGHT BLUE. LOW PRESSURE SIDE, OFF WHITE.
8. ALL VALVES INSIDE VAULT SHALL BE RATED FOR 250 PSI WORKING PRESSURE, OR HIGHER IF REQUIRED FOR PROJECT.
9. VAULT SHALL BE PRECAST CONCRETE. APPROVAL MUST BE GIVEN TO USE CAST IN PLACE CONCRETE. VAULT SHALL BE DESIGNED FOR HS-20 LOADING. THE LOCATION OF THE PRECAST JOINTS MUST BE APPROVED. SITE SPECIFIC APPROVAL REQUIRED.
10. SEAL ALL JOINTS WITH PREFORMED FLEXIBLE SEALANT CONFORMING TO ASTM C990, AND WRAP WITH EXTERNAL JOINT SEALANT MEETING ASTM C877. FILL JOINTS INSIDE VAULT WITH CAULK OR GROUT.
11. PROVIDE (2) 8 HR DAYS FOR TESTING, STARTUP, AND TRAINING FOR PRV VALVES WITH MANUFACTURER REPRESENTATIVE.
12. SEAL ALL VAULT PENETRATIONS WITH HYDROPHILIC NON-SHRINK GROUT.
13. 36" MINIMUM LANDSCAPE CLEARANCE AROUND HATCH REQUIRED.
14. 24" CLEAR, CONVENIENT AND UNINHIBITED ACCESS PATH REQUIRED TO HATCH.

| | | | |
|--|---------|--|--------------|
|  PARK CITY MUNICIPAL CORPORATION WATER | DATE | PRESSURE REDUCING VALVE VAULT | STD. PLAN |
| | 10/2020 | | 573-A |
| | REV. | | |
| | 1 | | |

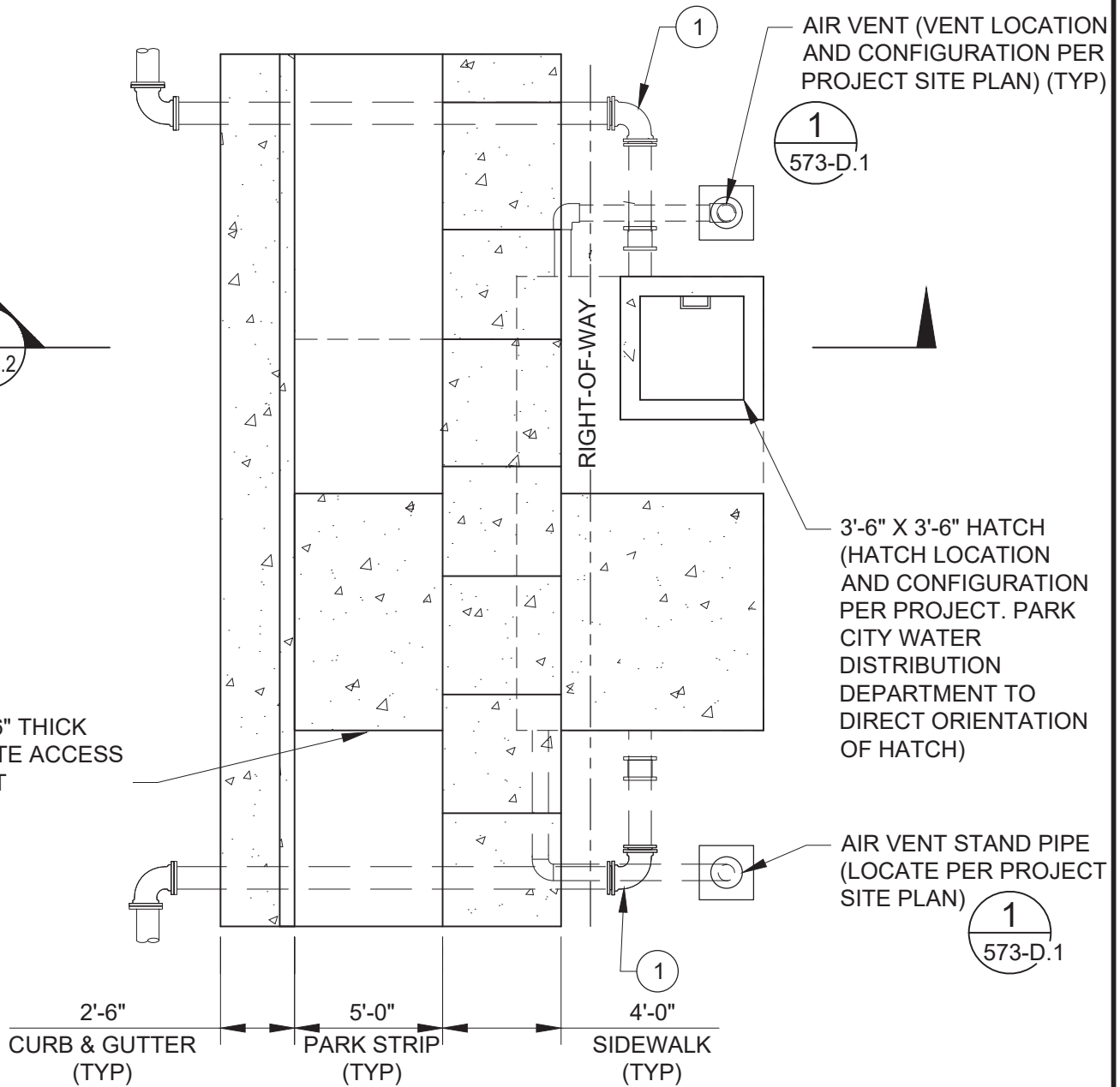

VAULT LOCATION PLAN

NTS

NOTES:

- 1. FOR GENERAL NOTES, SEE STD. PLAN 573-A, AND FOR (#) KEYED ITEMS, SEE STD. PLAN 573-C.3 AND C.4.
- 2. SITE SPECIFIC APPROVAL REQUIRED. NEW EASEMENTS WILL BE REQUIRED IF VAULT IS LOCATED OUTSIDE OF PROPERTY LINE.

| | | | |
|--|---------|--|----------------|
|  PARK CITY MUNICIPAL CORPORATION WATER | DATE | PRESSURE REDUCING VALVE VAULT | STD. PLAN |
| | 03/2024 | | 573-B.1 |
| | REV. | | |
| | 1 | | |

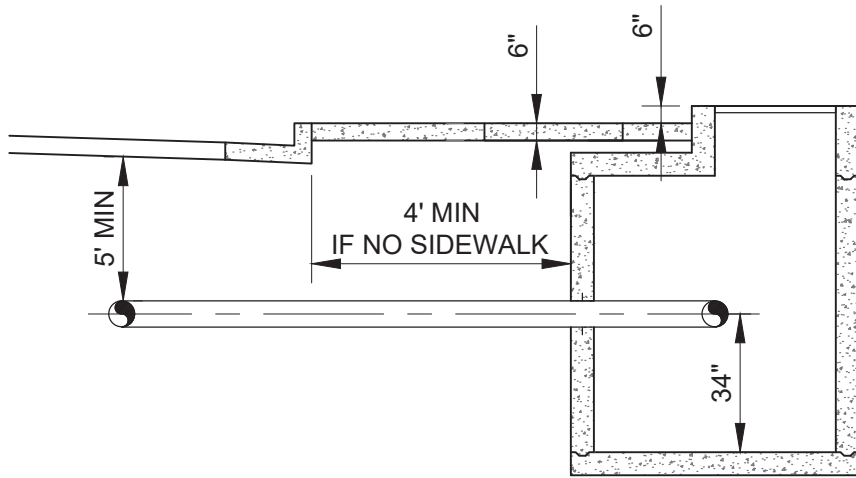

VAULT SECTION
NTS

A
573-B.1



PARK CITY MUNICIPAL CORPORATION
WATER

DATE

03/2024

REV.

1

**PRESSURE REDUCING
VALVE VAULT**

STD. PLAN

573-B.2

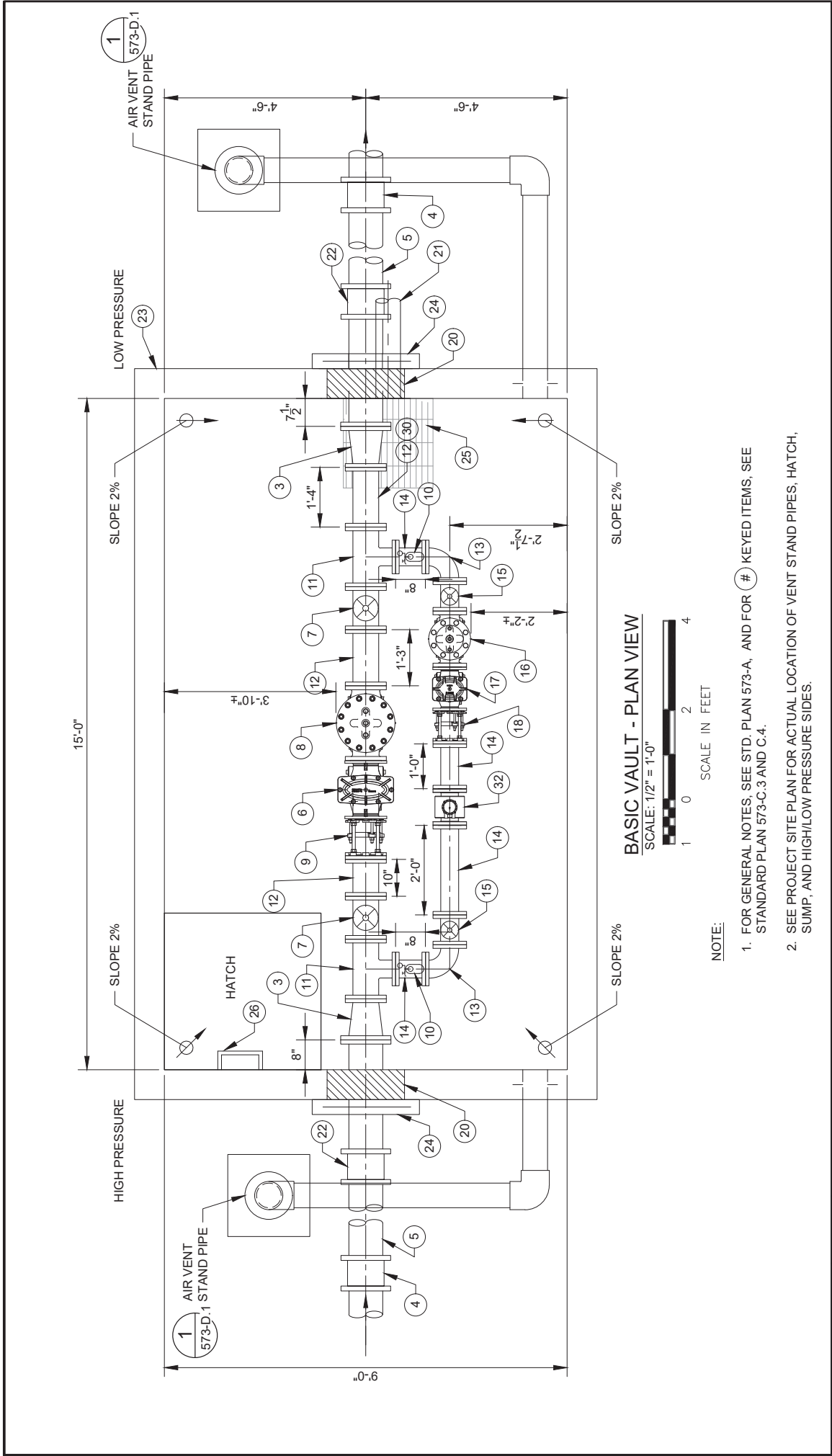

BASIC VAULT - PLAN VIEW

SCALE: 1/2" = 1'-0"



NOTE:

1. FOR GENERAL NOTES, SEE STD. PLAN 573-A, AND FOR (#) KEYED ITEMS, SEE STANDARD PLAN 573-C.3 AND C.4.
2. SEE PROJECT SITE PLAN FOR ACTUAL LOCATION OF VENT STAND PIPES, HATCH, SUMP, AND HIGH/LOW PRESSURE SIDES.

| | | |
|--|-----------------|---|
|  PARK CITY MUNICIPAL CORPORATION WATER | DATE 03/2024 | STD. PLAN 573-C.1 |
| | REV. 2 | PRESSURE REDUCING VALVE VAULT |

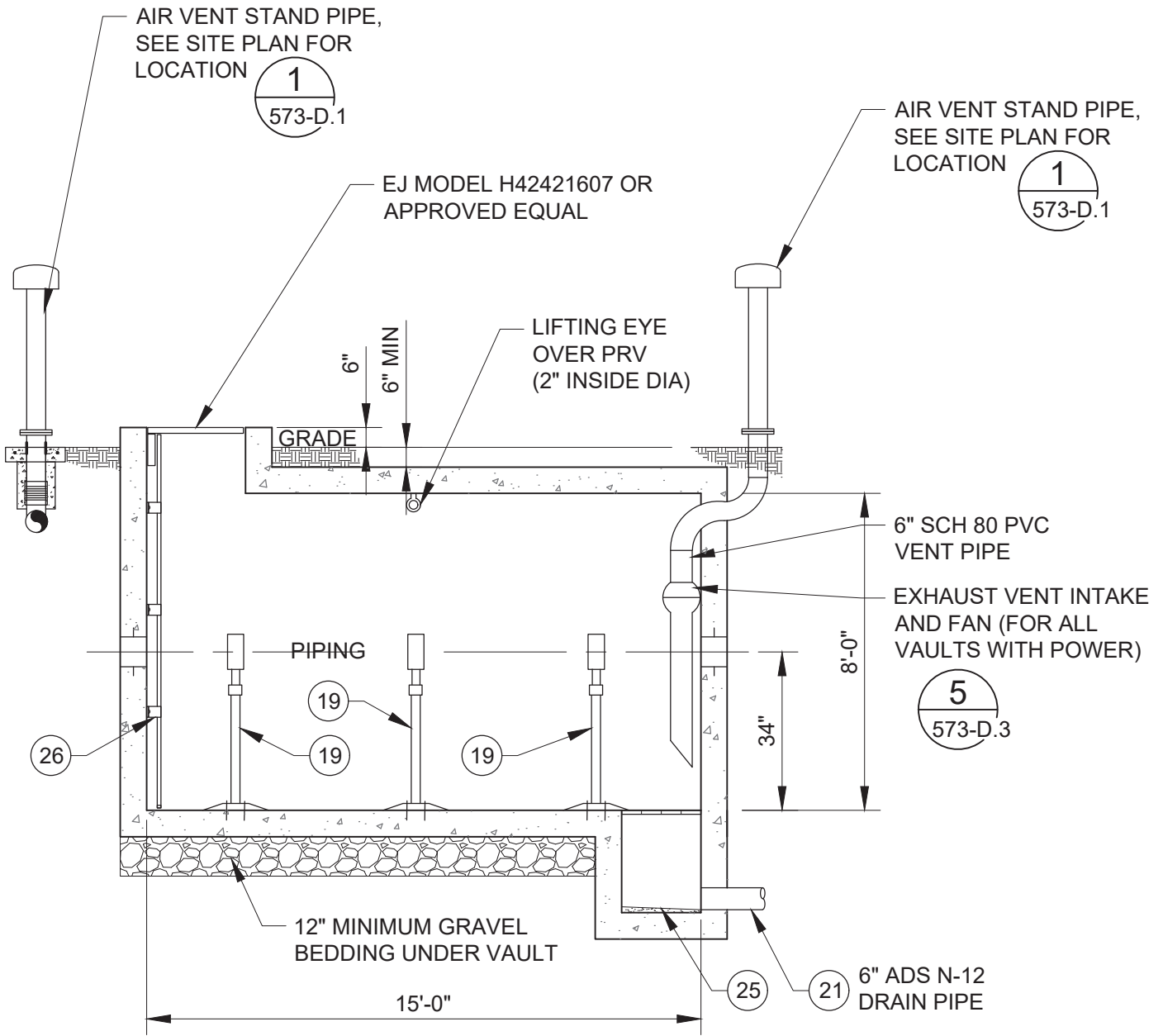

VAULT SECTION **(B)**
 NTS **(573-C.1)**

NOTES:

- FOR GENERAL NOTES, SEE STD. PLAN 573-A, AND FOR (#) KEYED ITEMS, SEE STD. PLAN 573-C.3 AND C.4.

| | | | |
|--|---------|---|----------------|
|  PARK CITY MUNICIPAL CORPORATION WATER | DATE | PRESSURE REDUCING VALVE VAULT | STD. PLAN |
| | 03/2024 | | 573-C.2 |
| | REV. | | |
| | 1 | | |

MATERIAL LIST

| ITEM | PRESSURE REDUCING VALVE VAULT |
|------|---|
| ① | INSTALL WATER MAIN WITH DI BENDS AS REQUIRED WITH RETAINER GLANDS AND THRUST BLOCKS |
| ② | INSTALL RESILIENT SEAT VALVE, FL X MJ, W/ TEE AND RETAINER GLANDS AND TRUST BLOCKS ON EXISTING WATER MAIN, SEE STD PLAN 570 |
| ③ | 8"x6" DI REDUCER FL X FL |
| ④ | DI WATER MAIN, USE FLEXIBLE OR DUCTILE IRON MJ SLEEVES (POWERSEAL MODEL 3506 POWERMAX OR EQUAL) AS NECESSARY TO LEVEL EXISTING LINES |
| ⑤ | DUCTILE IRON PIPE (EXISTING PIPE SIZE) |
| ⑥ | 6" CLA-VAL X 43 H (H STYLE STRAINER), FLANGED ENDS, 10 MESH SCREEN, CAGE SUPPORT, AND O-RING |
| ⑦ | 6" RESILIENT WEDGE GATE VALVE, FL X FL WITH HAND WHEEL |
| ⑧ | 6" PRESSURE REDUCING VALVE, CLA-VAL MODEL 92-01, FLANGE X FLANGE WITH MICRO-SWITCH (PRESSURE SUSTAINING VALVE IS REQUIRED UNLESS NOTED OTHERWISE) ALL BALL VALVES, WYE STRAINERS, PILOT CONTROLS, TRIM, SPEED CONTROLS AND ALL METALLIC INTERNAL COMPONENTS ARE TO BE STAINLESS STEEL. STAINLESS STEEL ANTI-CAVITATION MAY BE REQUIRED DEPENDING ON PRESSURE DIFFERENTIAL |
| ⑨ | 6" DISMANTLING JOINT, ROMAC DJ 400, OR EQUAL |
| ⑩ | 1" AIR VALVE AND PRESSURE TREE. SEE STD PLAN 573-D.1. |
| ⑪ | 6"x6"x4" FL DI TEE |
| ⑫ | 6" DI FL SPOOL |
| ⑬ | 4" DI FL 90° BEND |
| ⑭ | 4" DI FL SPOOL |
| ⑮ | 4" RESILIENT WEDGE GATE VALVE, FLxFL WITH HAND WHEEL |
| ⑯ | 4" PRESSURE REDUCING VALVE, CLA-VAL MODEL 92-01, FLANGE X FLANGE, (PRESSURE SUSTAINING VALVE IS REQUIRED UNLESS NOTED OTHERWISE) ALL BALL VALVES, WYE STRAINERS, PILOT CONTROLS, TRIM, SPEED CONTROLS AND ALL METALLIC INTERNAL COMPONENTS ARE TO BE STAINLESS STEEL. STAINLESS STEEL ANTI-CAVITATION TRIM MAY BE REQUIRED DEPENDING ON PRESSURE DIFFERENTIAL |
| ⑰ | 4" CLA-VAL X 43H (H STYLE STRAINER), FLANGED ENDS, 10 MESH SST SCREEN, CAGE SUPPORT, AND O-RING |
| ⑱ | 4" DISMANTLING JOINT, ROMAC DJ 400, OR EQUAL |



PARK CITY MUNICIPAL CORPORATION
WATER

DATE

03/2024

REV.

2

PRESSURE REDUCING VALVE VAULT

STD. PLAN

573-C.3

MATERIAL LIST (CON'T)

| ITEM | PRESSURE REDUCING VALVE VAULT |
|------|---|
| (19) | 2" STEEL PIPE SUPPORT STAND, ADJUSTABLE (3 REQUIRED ON 6" PIPE SYSTEM, 3 REQUIRED ON 4" PIPE SYSTEM), SEE STD. PLAN 578 |
| (20) | CORE DRILL OPENING WITH LINK-SEAL PIPE-TO-WALL SEAL. TYPICAL ON ALL OPENING. FILL OUTSIDE OPENINGS WITH NON-SHRINK GROUT AND CAULK |
| (21) | DRAIN SUMP, PIPE TO DAYLIGHT WITH DRAIN PIPE AND #4 SST RODENT PROTECTION SCREEN ON END OF PIPE. ROUTE AS SHOWN ON SITE PLAN. IF NO PIPE-TO-DAYLIGHT OPTION IS AVAILABLE, INSTALL A SUMP PUMP. CITY APPROVAL IS REQUIRED FOR A SUMP PUMP. SEE STD. PLAN 573-D.2 |
| (22) | 8" MJ SOLID SLEEVE, MEGA-LUG RESTRAINTS WITH CORE-TEN BOLTS |
| (23) | VAULT IN ACCORDANCE WITH 573-A AND 573-B A. PRECAST CONCRETE VAULT RATED FOR HS-20 LOADING. MAY BE CAST IN PLACE PER CITY APPROVAL. PROVIDE STAMPED STRUCTURAL DRAWINGS B. WATERPROOF OUTSIDE WALLS AND TOP SLAB PER IBC CODE FOR BURIED FOUNDATIONS |
| (24) | MECHANICAL JOINT DUCTILE IRON RETAINER GLAND WITH CONCRETE THRUST BLOCK, REINFORCE CONCRETE WITH (4) #4 EACH SIDE OF PIPE. |
| (25) | 30"x30"x30" SUMP. FRP GRATING, 1-1/2" THICK MIN. AND RATED FOR 300 LB/FT PEDESTRIAN TRAFFIC. |
| (26) | VAULT LADDER, SEE DETAIL 7 ON 573-D.4 |
| (27) | 3" PRESSURE RELIEF VALVE, CLA-VAL MODEL 50A-01 BKCX WITH MOUNTED LIMIT SWITCH OR MICRO SWITCH WITH SCADA CONNECT FOR "OPEN" ALARM CONDITION, SEE STD. PLAN 573-D.2 |
| (28) | IN-LINE GAUGE PRESSURE TRANSMITTER, ROSEMOUNT MODEL 3051TG 800 PSI ASSEMBLED TO INTEGRAL, 2-VALVE, ROSEMOUNT 306 MANIFOLD. SEE STD. PLAN 573-D.1. 4-20 MA ANALOG |
| (29) | 6"x6"x3" DI TEE FLANGE X FLANGE X FLANGE |
| (30) | 6" DI PIPE. IF VAULT HAS POWER, THIS ITEM SHALL BE REPLACED WITH ITEMS 29 AND 27. |
| (31) | SUMP PUMP: 2" SUMP PUMP, TSURUMI MODEL HSZ2.4S-62 OR EQUAL. SUMP PUMP REQUIRED IF DRAIN TO DAYLIGHT NOT AVAILABLE, SEE STD. PLAN 573-D.2 |
| (32) | 4" SIEMENS MAGNETIC FLOW METER, 5100 W |



PARK CITY MUNICIPAL CORPORATION
WATER

DATE

03/2024

REV.

2

**PRESSURE REDUCING
VALVE VAULT**

STD. PLAN

573-C.4

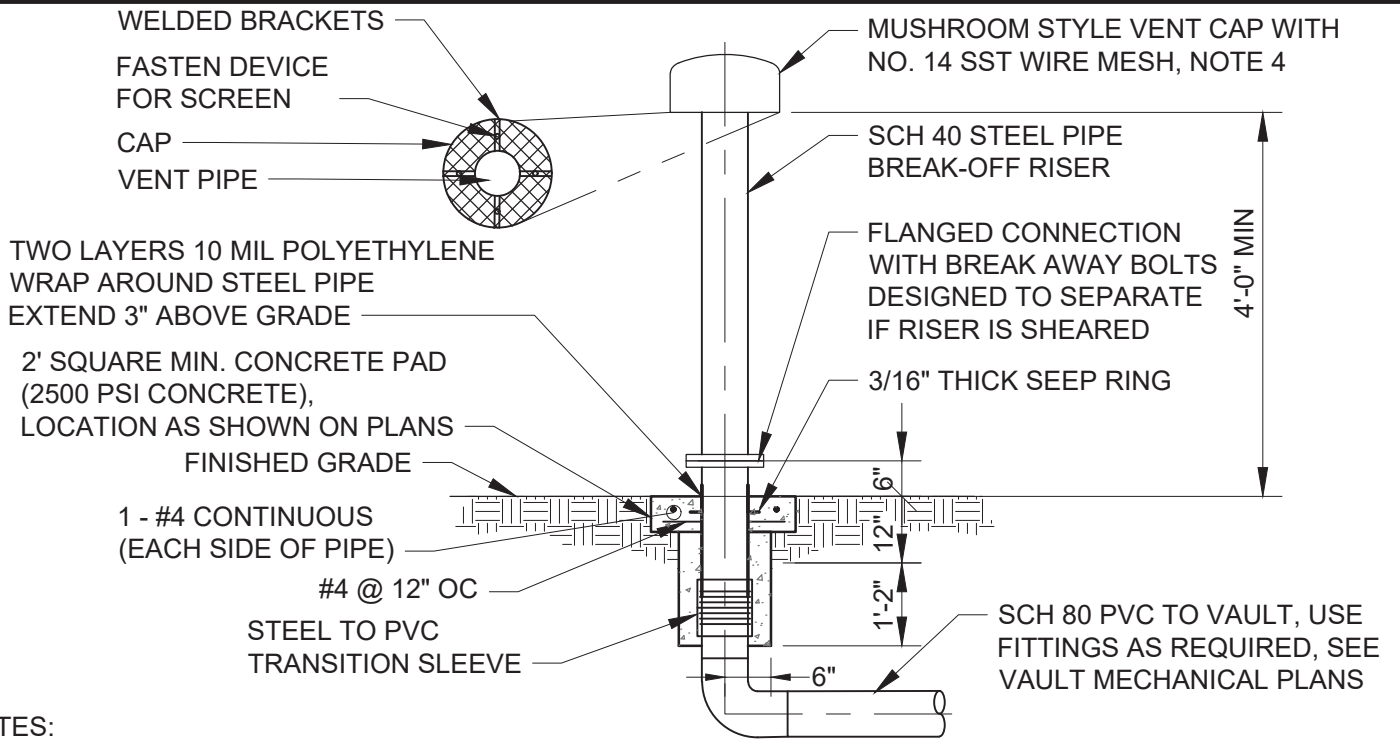

NOTES:

1. WELD ALL STEEL FITTINGS EXCEPT MATCHING BOLT ON FLANGE.
2. ALL ABOVE GRADE STEEL PIPING SHALL BE CORE-TEN BARE STEEL.
3. VENT CAP SHALL BE 12" DIA FOR 6" VENT PIPE. OTHER SIZES SHALL BE PROJECT SPECIFIC.
4. STEEL WALL PIPE WITH SEEP RING SHALL BE CAST IN VAULT FOR VENT PIPES INSTALLED ON TOP OF VAULTS.

AIR VENT STAND PIPE
NTS

1
573-B, 573-C

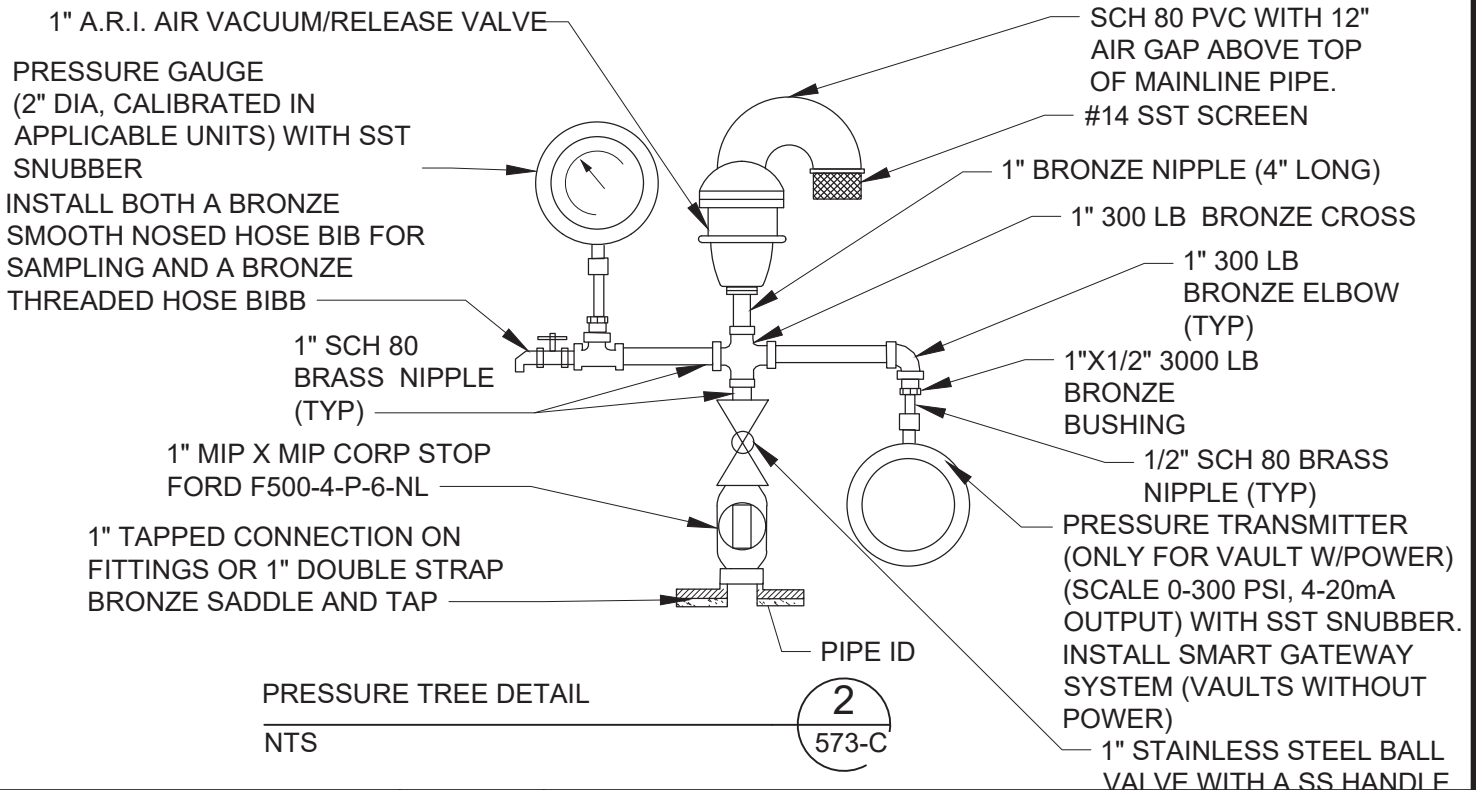

PRESSURE TREE DETAIL
NTS

2
573-C

| | | | |
|--|---------|--|----------------|
|  PARK CITY MUNICIPAL CORPORATION WATER | DATE | PRESSURE REDUCING VALVE VAULT | STD. PLAN |
| | 03/2024 | | 573-D.1 |
| | REV. | | |
| | 2 | | |

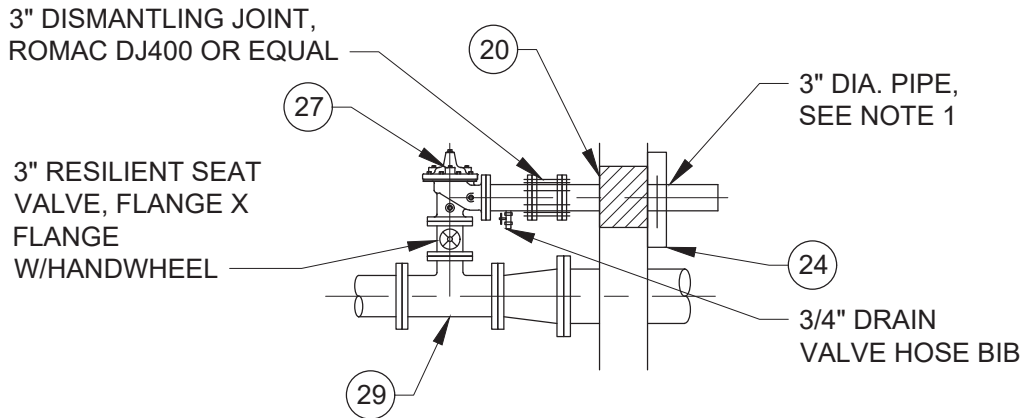

NOTES:

1. ROUTE TO NEAREST APPROVED DISCHARGE LOCATION WITH 12" AIR GAP AND #4 SST MESH SCREEN BETWEEN FLANGES AND EROSION CONTROL. ALL FITTINGS MUST BE FLANGED OR RESTRAINED. 5' MIN COVER.
2. FOR GENERAL NOTES, SEE STD. PLAN 573-A, AND FOR (#) KEYED ITEMS, SEE STD. PLAN 573-C.3 AND C.4

3" PRESSURE RELIEF VALVE DETAIL

NTS

3
573-C

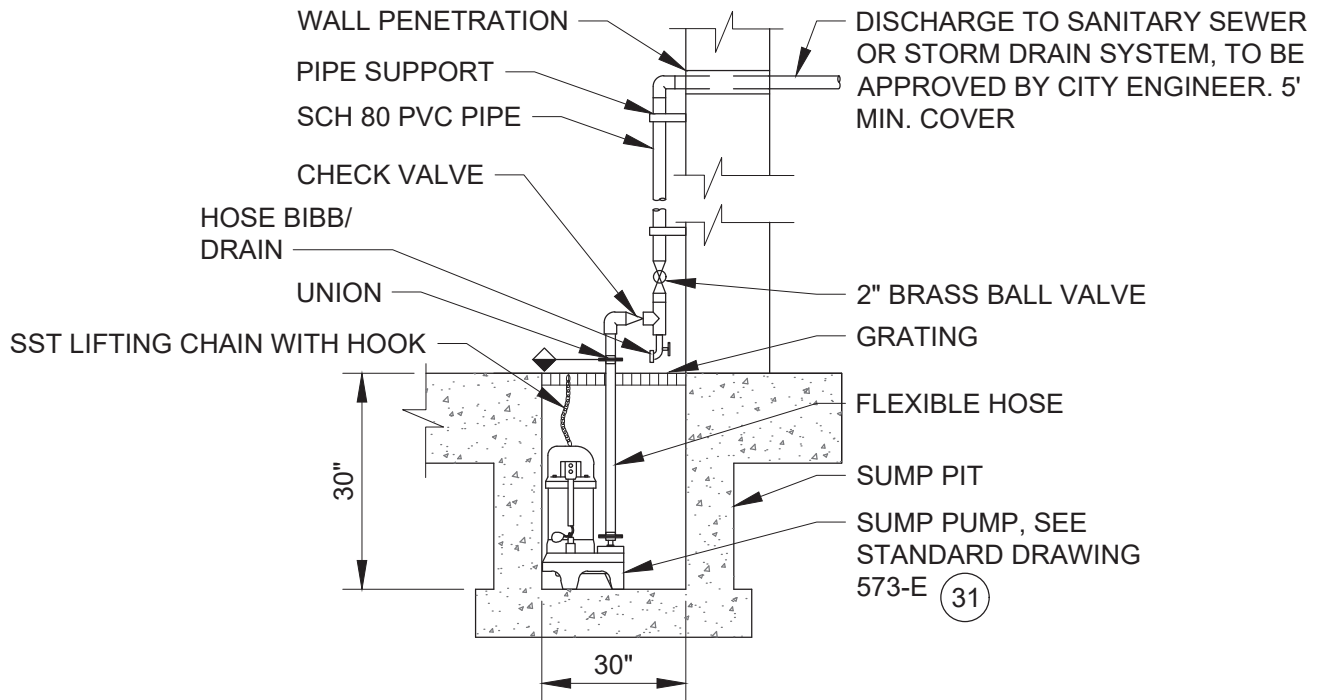

NOTES:

1. SUMP PUMP AND DISCHARGE PIPING SHALL NOT BE USED UNLESS SPECIFICALLY APPROVED BY THE CITY. SUMP SHALL DRAW TO DAYLIGHT UNLESS OTHERWISE APPROVED.
2. FOR GENERAL NOTES, SEE STD. PLAN 573-A, AND FOR (#) KEYED ITEMS, SEE STD. PLAN 573-C.3 AND C.4

TYPICAL SUMP SECTION DETAIL

NTS

4
573-C



PARK CITY MUNICIPAL CORPORATION
WATER

DATE

03/2024

REV.

1

**PRESSURE REDUCING
VALVE VAULT**

STD. PLAN

573-D.2

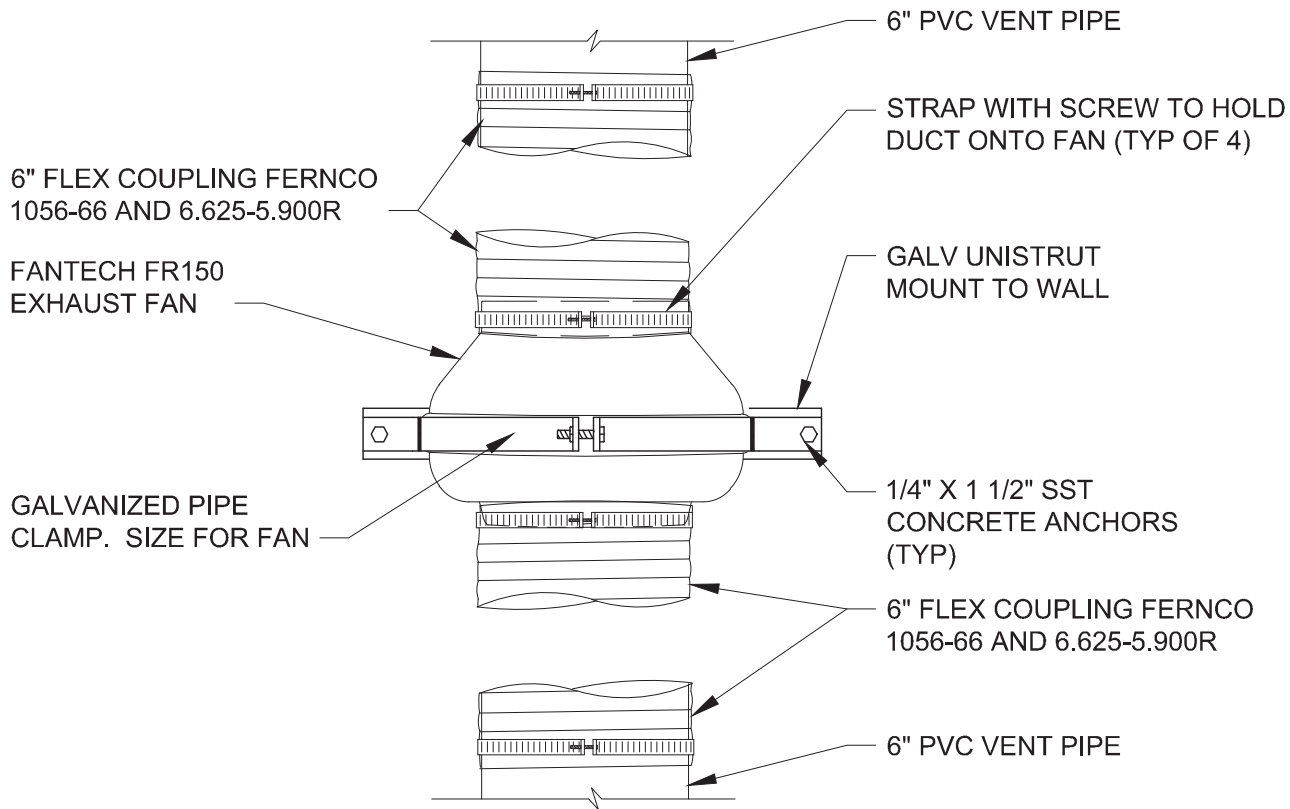

IN-LINE EXHAUST FAN DETAIL

5
573-C, 573-E

NTS

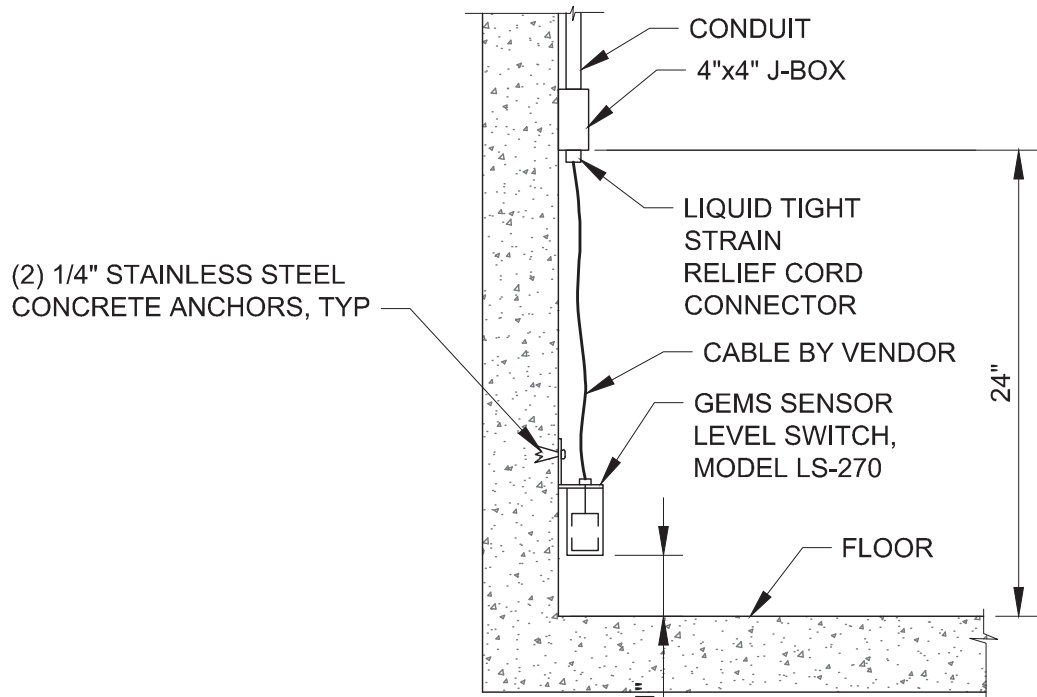

FLOOD SWITCH INSTALLATION DETAIL

6
573-E

NTS



| | |
|------|--------|
| DATE | 4/2014 |
| REV. | 0 |

PRESSURE REDUCING VALVE VAULT

STD. PLAN

573-D.3

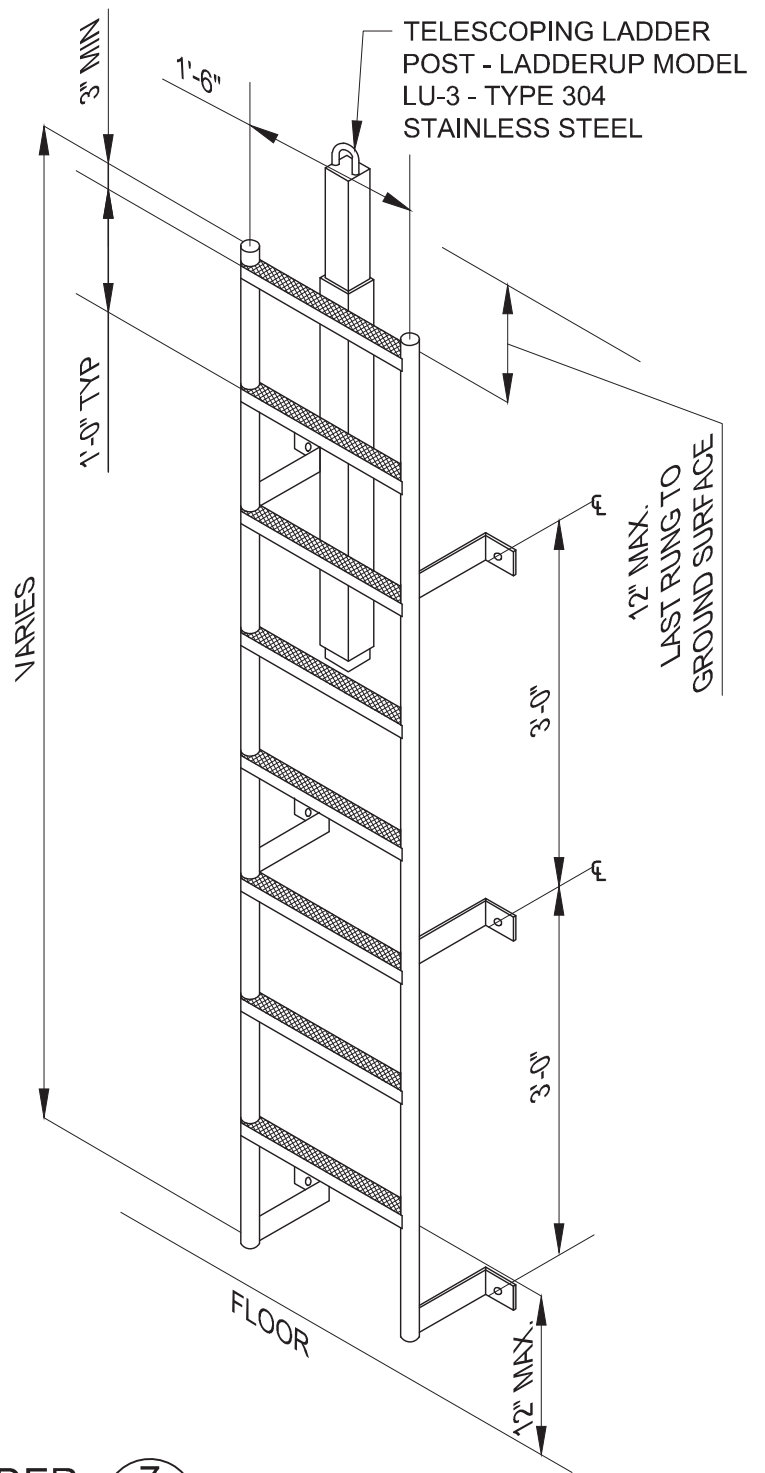
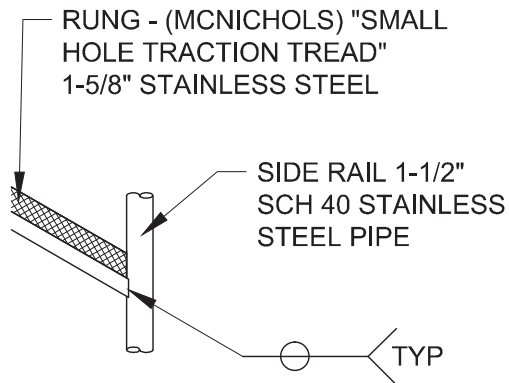
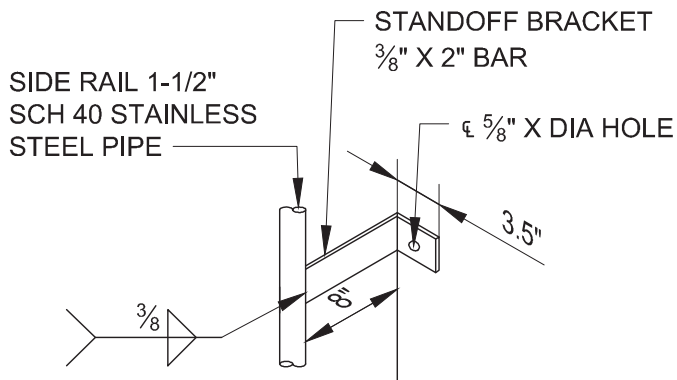

VAULT LADDER

NTS

7
573-C

NOTE:

- LADDER, ANCHORS, AND BOLTS TO BE STAINLESS STEEL



PARK CITY MUNICIPAL CORPORATION
WATER

DATE

4/2014

REV.

0

**PRESSURE REDUCING
VALVE VAULT**

STD. PLAN

573-D.4

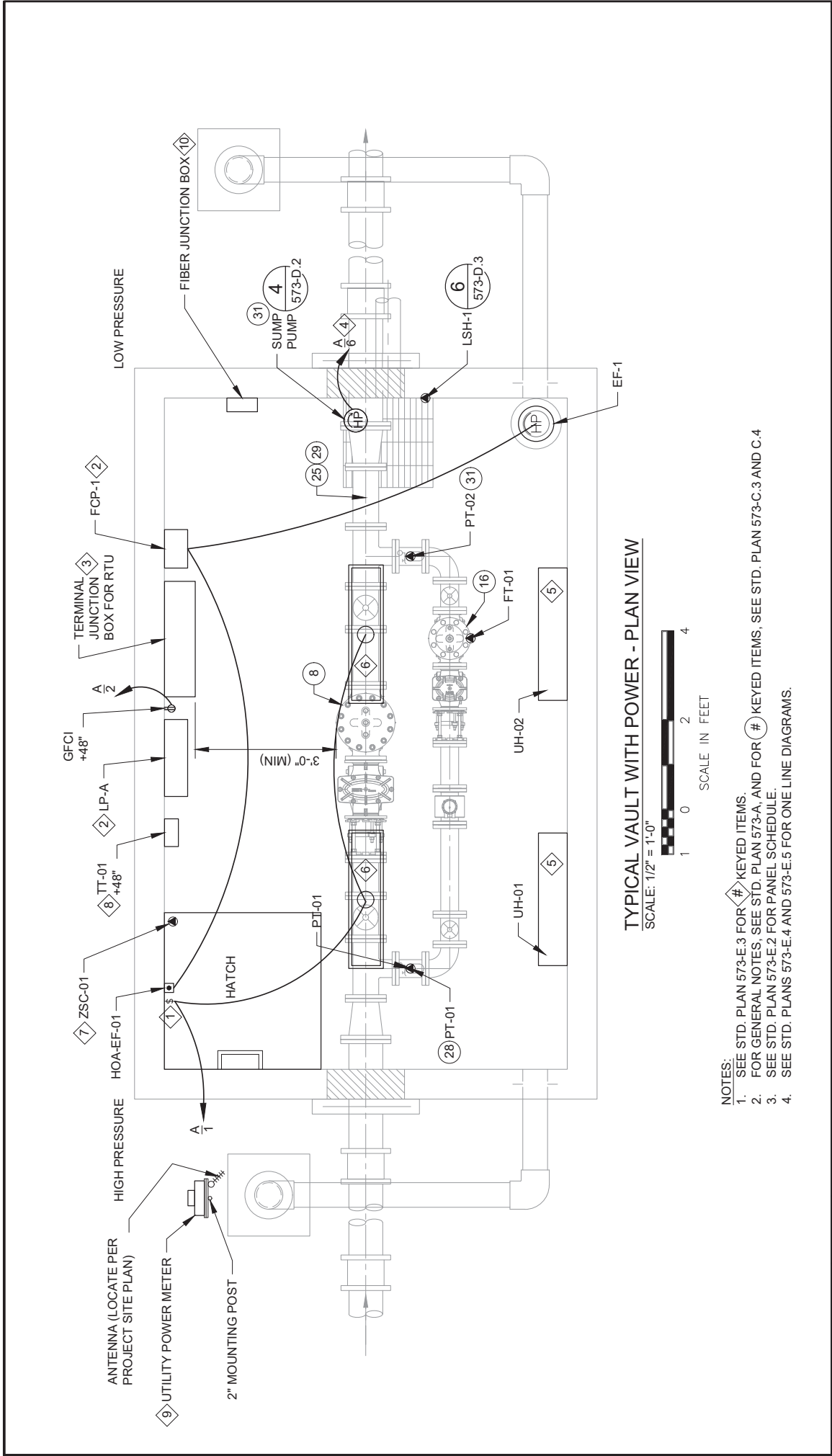

TYPICAL VAULT WITH POWER - PLAN VIEW

SCALE: 1/2" = 1'-0"

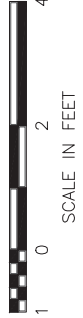

NOTES:

1. SEE STD. PLAN 573-E.3 FOR # KEYPED ITEMS.
2. FOR GENERAL NOTES, SEE STD. PLAN 573-A, AND FOR # KEYPED ITEMS, SEE STD. PLAN 573-C.3 AND C.4
3. SEE STD. PLAN 573-E.2 FOR PANEL SCHEDULE.
4. SEE STD. PLANS 573-E.4 AND 573-E.5 FOR ONE LINE DIAGRAMS.

| | |
|------|---------|
| DATE | 03/2024 |
| REV. | 1 |



PRESSURE REDUCING VALVE VAULT

STD. PLAN

573-E.1

PANEL SCHEDULE LP-A

| | | | |
|-----------------------------------|---------------------------------|--------------|----------------|
| LOCATION: IN VAULT | MFGR: CULTER HAMMER OR EQUAL | 100 AMPS | VOLTS: 120/240 |
| DIMENSIONS: SIZE BY CONTRACTOR | TYPE: PANELBOARD | M.L.O. | PHASE: 1 |
| MOUNTING: SURFACE | NEMA: 3R | 50 M.C.B. | WIRES: 3 |
| FEED: TOP | | 10000 A.I.C. | |

| | | | | | | PHASE LOADS | | | | | | | | | |
|------|---|-----------------------|--------------------|------------------|----|-------------|---------|-------|---------|----|------------------|----------------|-------------------------|------|---|
| BRKR | | DESCRIPTION | CONT. WATT S | N-CONT. WATTS | NO | A | | B | | NO | N-CONT. WATTS | CONT. WATTS | DESCRIPTION | BRKR | |
| A | P | | | | | CONT. | N-CONT. | CONT. | N-CONT. | | | | | A | P |
| 20 | 1 | LIGHTS | | 148 | 1 | 0 | 328 | | | 2 | 180 | | OUTLETS | 15 | 1 |
| 20 | 1 | RTU | | 500 | 3 | | | 0 | 1246 | 4 | 746 | | SUMP PUMP OUTLET | 20 | 1 |
| 20 | 2 | UNIT HEATER (UH-1) | 1000 | | 5 | 500 | 0 | 500 | 0 | 6 | 560 | | FAN CONTROL PANEL | 20 | 1 |
| 20 | 2 | UNIT HEATER (UH-2) | 1000 | | 7 | 500 | 0 | 500 | 0 | 8 | | | SPARE | 20 | 1 |
| 20 | 1 | SPARE | | | 9 | 0 | 0 | | | 10 | | | SPARE | 20 | 1 |
| 20 | 1 | SPARE | | | 11 | | | 0 | 0 | 12 | | | SPACE | | |
| | | SPACE | | | 13 | 0 | 0 | | | 14 | | | SPACE | | |
| | | SPACE | | | 15 | | | 0 | 0 | 16 | | | SPACE | | |
| | | SPACE | | | 17 | | | | | 18 | | | SPACE | | |

| | | | | | | | | |
|---------------------------|-------|-----|-------|-----|-------|------|-------|---|
| TOTAL WATTS: | 2000 | 648 | 1,000 | 328 | 1,000 | 1246 | 1,486 | 0 |
| CONTINUOUS LOAD: | 2000 | | | | | | | |
| CONTINUOUS LOAD *125%: | 2,500 | | | | | | | |
| NON-CONTINUOUS LOAD: | 2,134 | | | | | | | |
| DESIGN WATTS: | 4,634 | | | | | | | |
| MIN. RATING (AMPS): | 13 | | | | | | | |

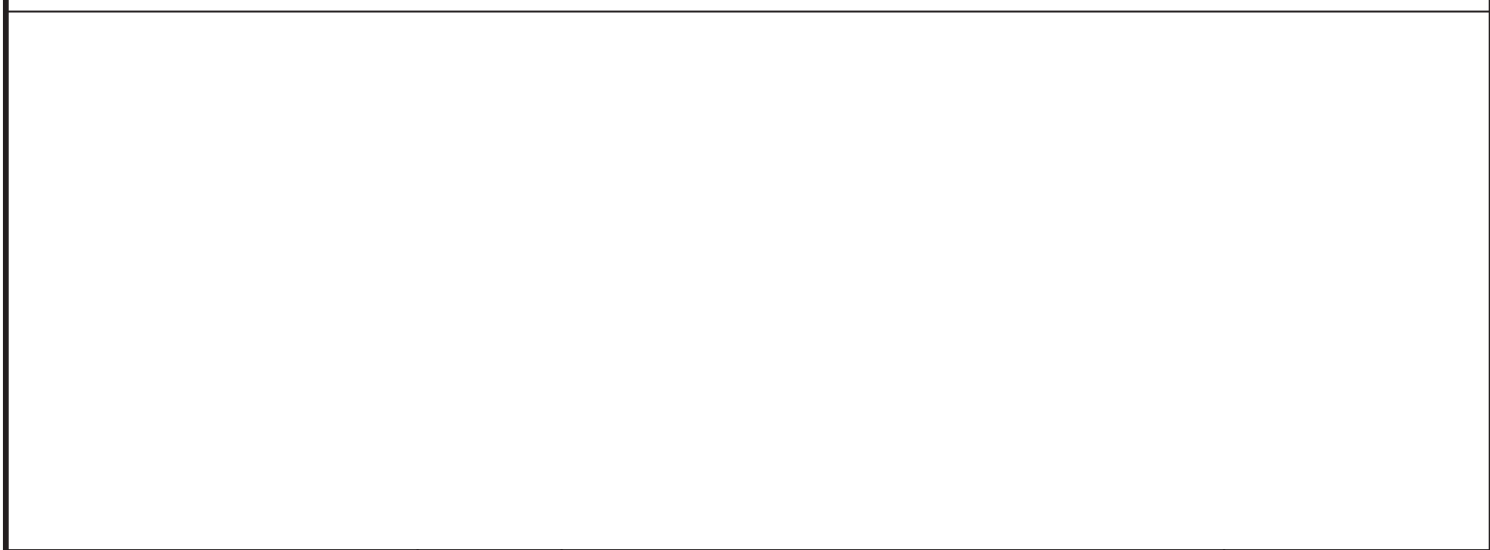

| | | | |
|--|---------|---|-------------------------------------|
|  PARK CITY MUNICIPAL CORPORATION WATER | DATE | <h3 style="margin: 0;">PRESSURE REDUCING VALVE VAULT</h3> | STD. PLAN |
| | 03/2024 | | <h2 style="margin: 0;">573-E.2</h2> |
| | REV. | | |
| | 1 | | |

PANEL NOTE:

- ① INSTALL WEATHERPROOF LIGHT SWITCH AND NEMA 4X HOA CONTROL BOX IN HATCH OPENING ABOUT 8" FROM TOP OF CONCRETE.
- ② MAINTAIN NATIONAL ELECTRICAL CODE REQUIRED CLEARANCE AND WORKING SPACE AROUND PANELS.
- ③ COORDINATE WITH PCMC FOR RTU PANEL, ANTENNA, AND CABLE REQUIREMENTS. CONTRACTOR TO FURNISH AND INSTALL RTU PANEL, ANTENNA, ANTENNA MAST, CONDUIT, CONDUCTOR, AND CABLE WITH WIRING TERMINATIONS INSIDE THE RTU PANEL. CONTRACTOR TO SIZE RTU RELATED EQUIPMENT FOR 11 I/O POINTS INCLUDING 3 SPARES. (1 FLOW METER, 2 PRESSURE TRANSDUCERS, 1 TEMPERATURE SENSOR, 1 FLOOD ALARM, 1 ENTRY SECURITY ALARM, 1 PRESSURE RELIEF OPEN ALARM, 2 SPARE DIGITAL INPUTS AND 2 SPARE ANALOG INPUTS). PCMC WILL PROVIDE AND INSTALL A PRE-ASSEMBLED AND PRE-WIRED BACKPANEL IN RTU PANEL AND PROVIDE SCADA PROGRAMMING.
- ④ SUMP PUMP TO BE HARDWIRED TO PANEL LP-A.
- ⑤ INSTALL 4-FOOT BASEBOARD HEATER AT 2-FEET ABOVE FINISHED FLOOR OF VAULT. HEATER SHALL BE 240 V WITH 3,400 BTUH, INTEGRAL DIAL THERMOSTAT.
- ⑥ GASKETED AND ENCLOSED INDUSTRIAL FIXTURE, FIBERGLASS HOUSING, WET LOCATION TWO LAMP FLUORESCENT, 120 VOLT, INSTANT START ELECTRONIC BALLAST METALUX VT3-232DR-120V-EB81-WL-U OR EQUAL. MOUNT FIXTURE ON WALL AT ABOUT 7 FEET ABOVE FINISHED FLOOR.
- ⑦ NEMA 4 HEAVY-DUTY LIMIT SWITCH WITH 1NO 1NC CONTACT 5A 120 VAC. SQUARE D COMPANY, CLASS 9007 OR EQUAL.
- ⑧ ROOM TEMPERATURE DISPLAY AND 4-20 mA TRANSMITTER WITH 100 OHM PLATINUM RTD. DEVAR MODEL D-RTTI-0024.
- ⑨ INSTALL UTILITY POWER METER WITH 50 AMP BREAKER ON BACK TO BACK UNISTRUT TO 2" GALVANIZED STEEL POLE ACCORDING TO UTILITY COMPANY STANDARDS.
- ⑩ IF FIBER IS AVAILABLE, INSTALL JUNCTION BOX FOR FIBER CONNECTION. COORDINATE SIZE OF BOX WITH PROVIDER.

| | | | |
|---|---------|---|-----------------------|
|  <p>PARK CITY 1884 PARK CITY MUNICIPAL CORPORATION WATER</p> | DATE | <p>PRESSURE REDUCING VALVE VAULT</p> | STD. PLAN |
| | 03/2024 | | <p>573-E.3</p> |
| | REV. | | |
| | 2 | | |

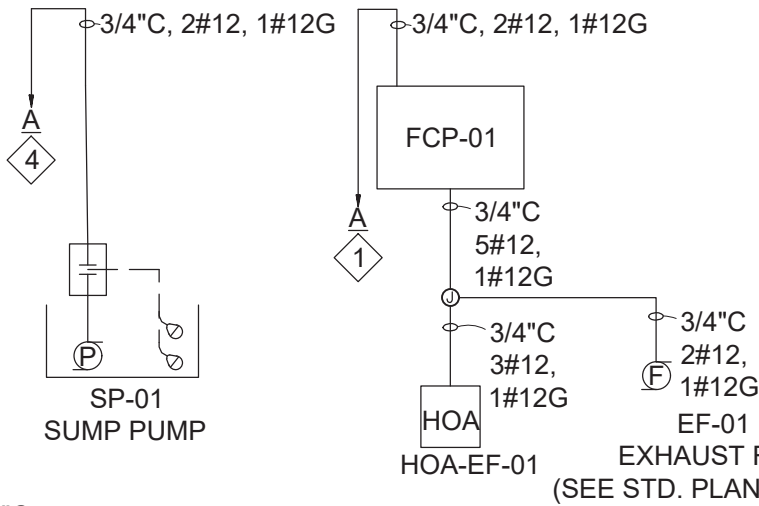

GENERAL NOTES:

1. REFER TO STD. PLAN 573-E.1 FOR EQUIPMENT LOCATIONS, 573-E.2 FOR PANEL SCHEDULE, AND 573-E.3 FOR # KEYED ITEMS.

LEGEND

- AI - ANALOG INPUT
- DI - DIGITAL INPUT
- TSP - TWISTED SHIELDED PAIR CABLE

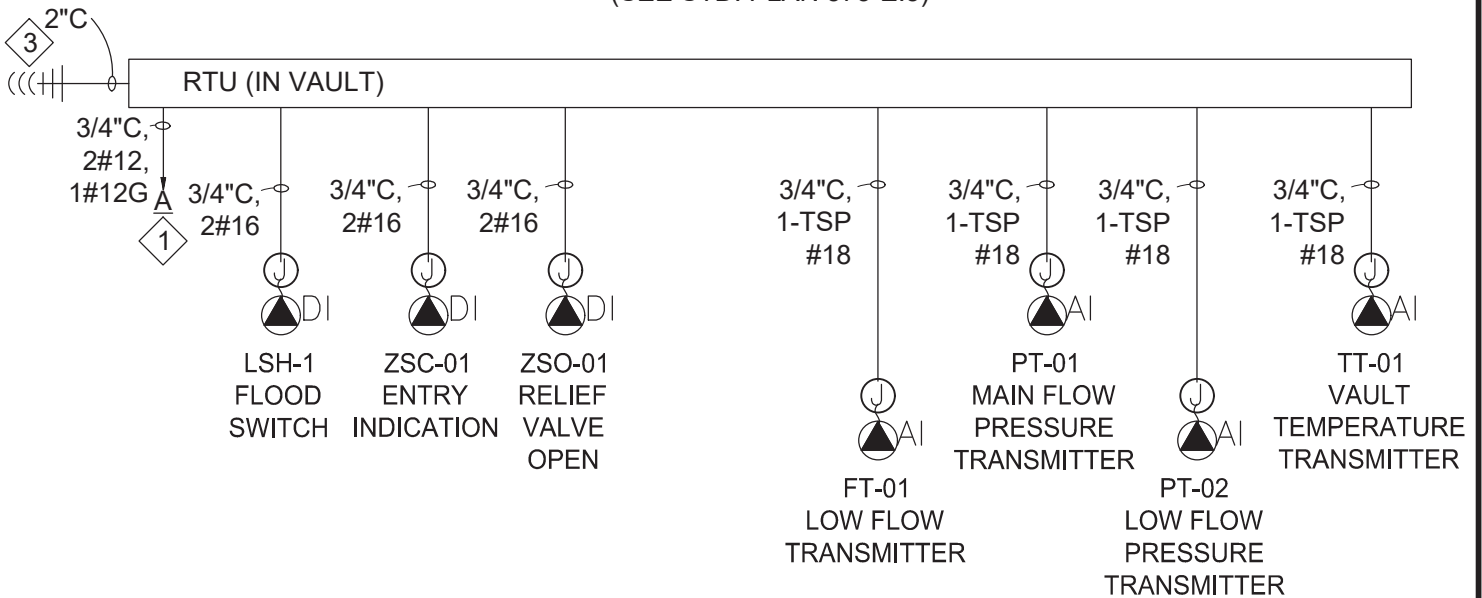

CONTROL ONE-LINE DIAGRAM

| | | | |
|---|---------|---|-----------------------|
| <p>PARK CITY MUNICIPAL CORPORATION WATER</p> | DATE | <p>PRESSURE REDUCING VALVE VAULT</p> | STD. PLAN |
| | 03/2024 | | <p>573-E.4</p> |
| | REV. | | |
| | 1 | | |

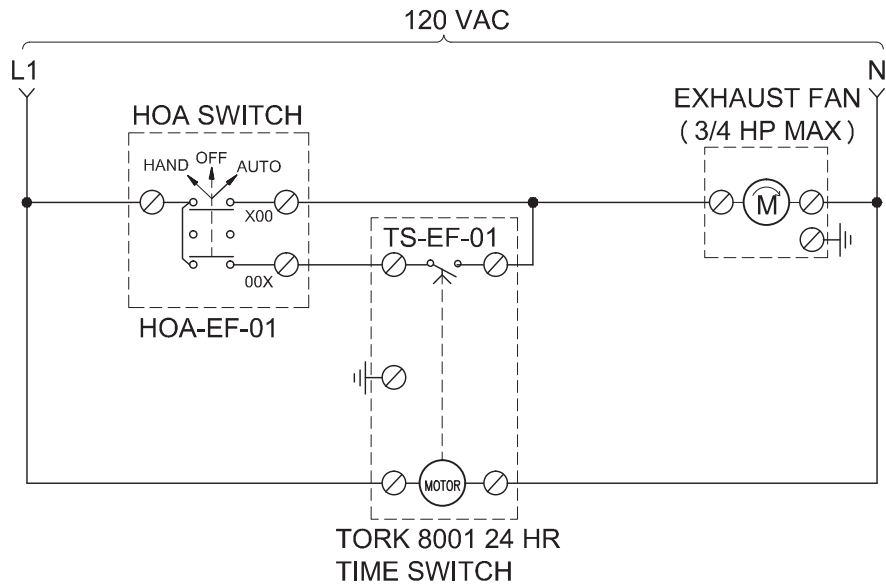

TYPICAL VAULT EXHAUST FAN CONTROL SCHEMATIC

NTS

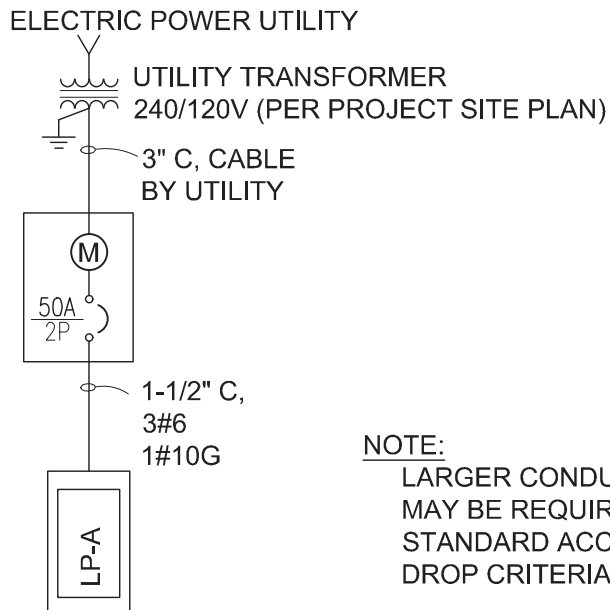

POWER ONE-LINE

NTS



PARK CITY MUNICIPAL CORPORATION
WATER

DATE

4/2014

REV.

0

PRESSURE REDUCING VALVE VAULT

STD. PLAN

573-E.5

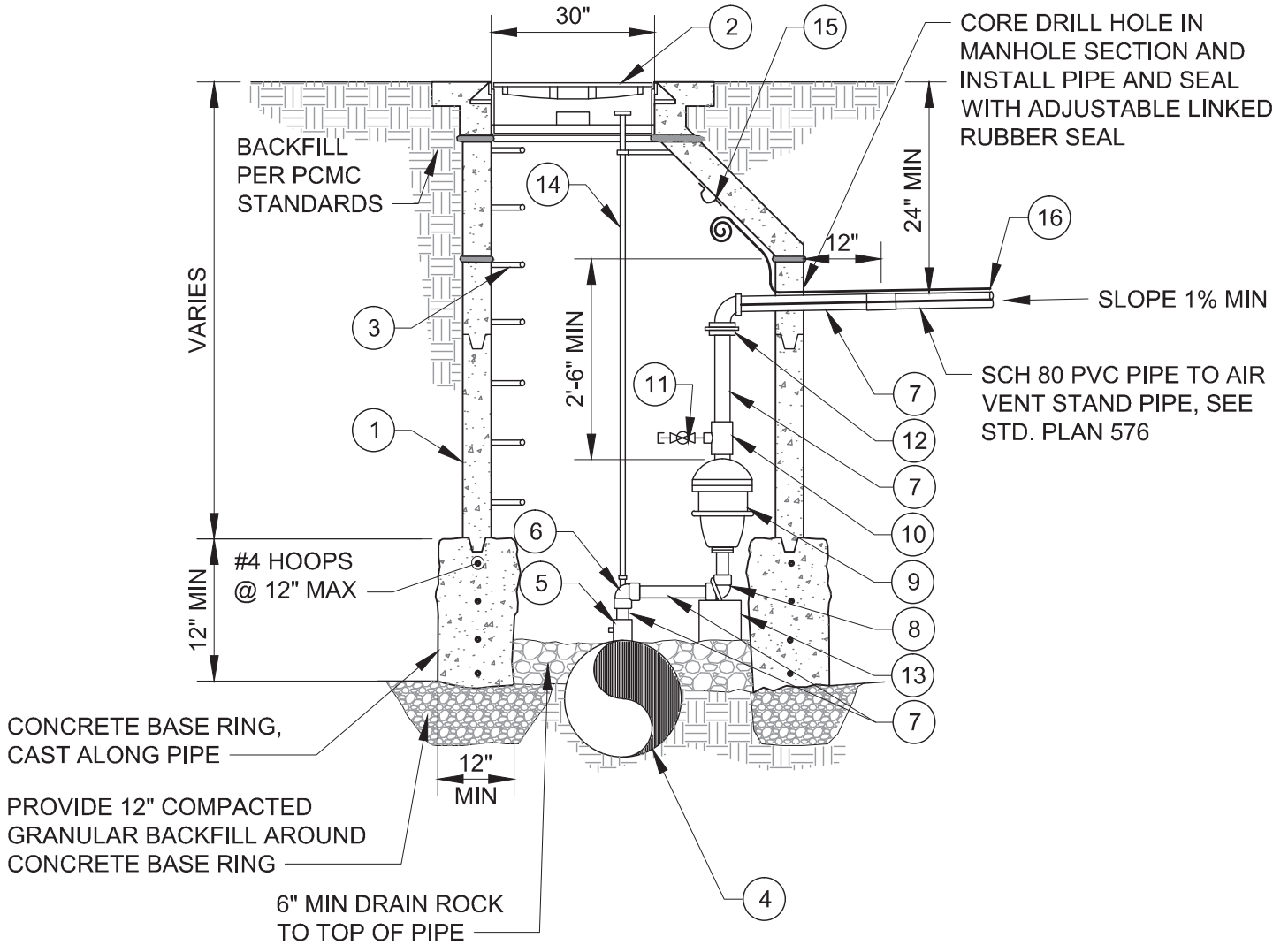

PARK CITY MUNICIPAL CORPORATION
WATER

DATE

3/2014

REV.

0

AIR RELEASE / CAV VALVE MANHOLE

STD. PLAN

574

LEGEND AND APPROVED PARTS LIST

| ITEM | DESCRIPTION | ACCEPTABLE MANUFACTURER | MODELS |
|------|---|--------------------------------|---|
| ① | 5' DIA. MANHOLE, PRECAST CONCRETE ECCENTRIC CONE AND WALL SECTIONS | | ASTM C 478 |
| ② | MANHOLE FRAME AND COVER (STD. PLAN 529) | | |
| ③ | POLYPROPYLENE ENCASED GRADE 60 STEEL STEPS AT 13" C-C, 13-1/2" TREAD WIDTH | M.A. INDUSTRIES OR APP'D EQUAL | PS2-PFDF |
| ④ | VALVE LARGER THAN 2": DUCTILE IRON FLANGED TEE WITH 4" BLIND FLANGE BRONZE AND NPT SERVICE TAP VALVE 2" AND SMALLER: BRONZE SERVICE SADDLE DI MAIN; DOUBLE STRAP PVC MAIN; TWO-PIECE BOLTED | MUELLER | DI PIPE SADDLE: BR2B SERIES, I.P. THDS; PVC PIPE SADDLE: H-13000 SERIES, I.P. THDS |
| | | FORD | DI PIPE SADDLE: STYLE 202B I.P. THDS; PVC PIPE SADDLE: STYLE S92, I.P. THDS |
| ⑤ | BRASS CORPORATION STOP, INLET I.P. THREAD, OUTLET F.I.P. THREAD (VALVE INLET SIZE) | MUELLER | B-20046N |
| | | FORD | FB1100-(SERVICE SIZE)-Q-NL |
| ⑥ | BRONZE ANGLE VALVE, 300 PSI (VALVE INLET DIAMETER) | | |
| ⑦ | BRASS NIPPLES X LENGTH AS REQUIRED, M.I.P., (VALVE INLET DIAMETER) | | |
| ⑧ | BRASS 90° ELBOW, F.I.P. (VALVE INLET/OUTLET DIAMETER) | | |
| ⑨ | COMBINATION AIR VACUUM / RELEASE VALVE, NPT, SIZE PER ENGINEER DESIGN AND APPROVED PLANS | | |
| ⑩ | BRONZE TEE, F.I.P., THREADED, (VALVE OUTLET DIAMETER X 3/4" DIA.) | | |
| ⑪ | DRAIN ASSEMBLY: 3/4" DIA. BRASS CLOSE NIPPLE, M.I.P.; 3/4" BRONZE BALL VALVE; 3/4" BRONZE PLUG | MUELLER | SERIES 300 VALVE; H-10035 |
| ⑫ | BRONZE UNION, (VALVE OUTLET DIAMETER) | | |
| ⑬ | CAV ASSEMBLY SUPPORT, (1) 16"X8"X8" CMU BLOCK | | |
| ⑭ | 5/8" DIAMETER GALVANIZED STEEL ROD WITH 3" DIAMETER HAND WHEEL TO FORM EXTENSION, TOGETHER WITH A GALVANIZED EYELET STANDOFF | | |
| ⑮ | LIFTING EYE ABOVE AIR VALVE, GALVANIZED | | |
| ⑯ | TRACER WIRE: 12 GA. SOLID, BLUE PVC INSULATION; WIRE-WIRE CONNECTORS SILICONE-FILLED WIRE NUTS | IDEAL INDUSTRIES | TWISTER DB PLUS OR APP'D EQUAL |

DETAIL NOTES

1. ALL VALVES AND FITTINGS SHALL BE RATED FOR THE SAME WORKING AND TEST PRESSURES AS THE CONNECTED WATERLINE
2. LOCATE VALVE, VAULT, AND AIR VENT PER APPROVED PLANS AND SET VAULT PLUMB
3. REFER TO STD. PLAN 575 FOR HEAT TRACE REQUIREMENTS

| | | | |
|--|-------------|--|------------------|
|  PARK CITY MUNICIPAL CORPORATION WATER | DATE | AIR RELEASE / CAV VALVE MANHOLE | STD. PLAN |
| | 10/2020 | | 574 S |
| | REV. | | |
| | 1 | | |

KEY NOTES:

- 1 WRAP HEAT TAPE AROUND THE AIR/VAC VALVE. USE MANUFACTURER'S RECOMMENDATIONS FOR THE NUMBER OF WRAPS.
- 2 SECURE THE HEATING CABLE IN PLACE WITH CHROMALOX FT-3 FIBERGLASS TAPE.
- 3 END KIT WITH INDICATING LIGHT.
- 4 INSULATE THE ISOLATION VALVE AND THE COMBINATION AIR VACUUM RELEASE VALVE WITH A REMOVABLE AND REUSABLE INSULATING BLANKET. ENERGY-WRAP INSULATION SYSTEM AS MANUFACTURED BY THERMAL ENERGY PRODUCTS.
- 5 INSTALL CHROMALOX AT-1 ALUMINUM TAPE NEXT TO PVC PIPE BEFORE INSTALLING HEAT TAPE AND THEN THE HEAT TAPE WILL CONTINUE FROM THE AIR/VAC VALVE AND LAY ALONG THE ALUMINUM TAPE.
- 6 INSULATE THE PIPE WITH 2 INCH THICK FIBERGLASS PIPE INSULATION.

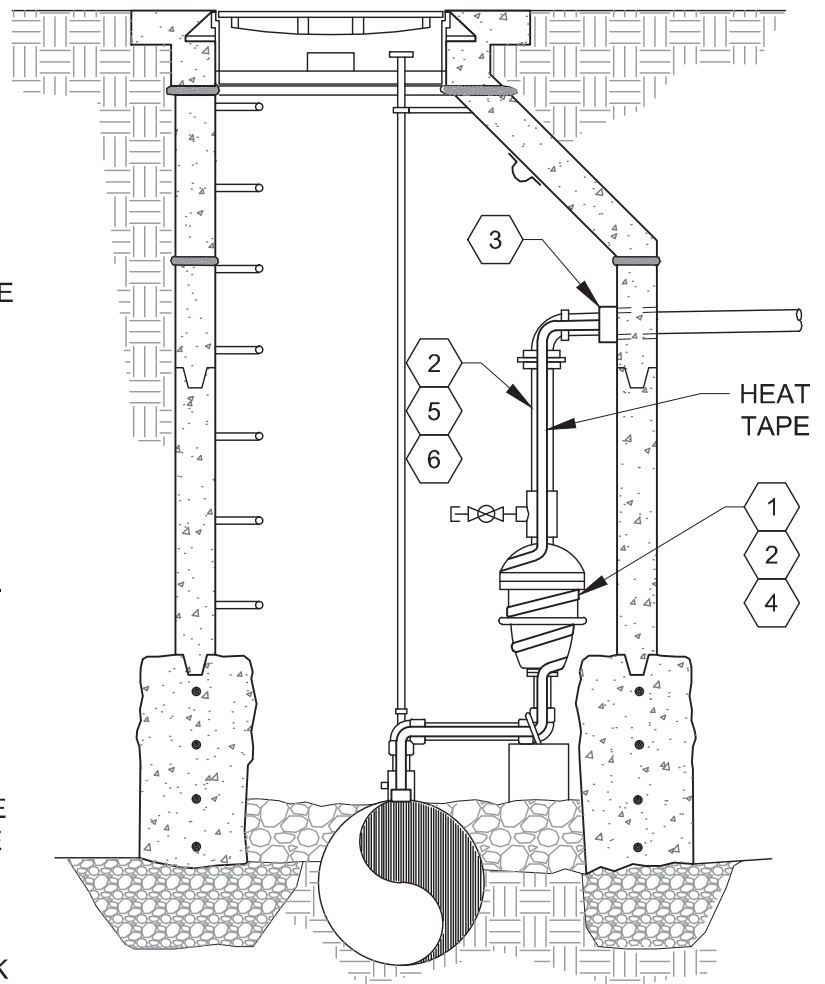

NOTES:

1. INSTALL HEAT TAPE IN ACCORDANCE WITH MANUFACTURER'S RECOMMENDATIONS.
2. REFER TO STD. PLAN 575-B FOR POWER ONE-LINE DETAIL.
3. SEE AIR RELEASE / CAV VALVE MANHOLE, STD. PLAN 574



PARK CITY MUNICIPAL CORPORATION
WATER

DATE

3/2014

REV.

0

HEAT TAPE INSTALLATION FOR AIR RELEASE / CAV VALVE

STD. PLAN

575-A

KEY NOTES:

- 1 TYPE 4X NONMETALLIC J-BOX FOR WIRE CONNECTIONS AS NEEDED.
- 2 CROUSE HINDS FS BOX, WITH 20 AMP SINGLE POLE SWITCH, AND A CROUSE HINDS P/N DS185 COVER.
- 3 CHROMALOX NON INDICATING TEMPERATURE CONTROL, 0 TO 150 DEGREES F, P/N PIT-15.
- 4 CHROMALOX PIPE MOUNTED POWER CONNECTION BOX NEMA 4X, P/N RTPC.
- 5 HEAT TAPE 120 VOLT, 5 WATTS PER FOOT, SELF-REGULATING, TINNED COPPER BRAID, WITH A FLUOROPOLYMER OVERJACKET. CONNECT GROUNDING CONDUCTOR TO COPPER BRAID. CHROMALOX P/N SRL 5-1CT HEATING CABLE.
- 6 END KIT WITH INDICATING LIGHT 120 VOLT, CHROMALOX P/N RTPC-SL1.
- 7 3/4" RIGID CONDUIT GALVANIZED WITH TWO #12 CONDUCTORS AND ONE #12 GROUND.
- 8 1/2" RIGID CONDUIT GALVANIZED WITH TWO #12 CONDUCTORS AND ONE #12 GROUND.
- 9 3/4" RIGID T CONDUIT GALVANIZED BODY WITH ONE REDUCER FOR 1/2" CONDUIT.

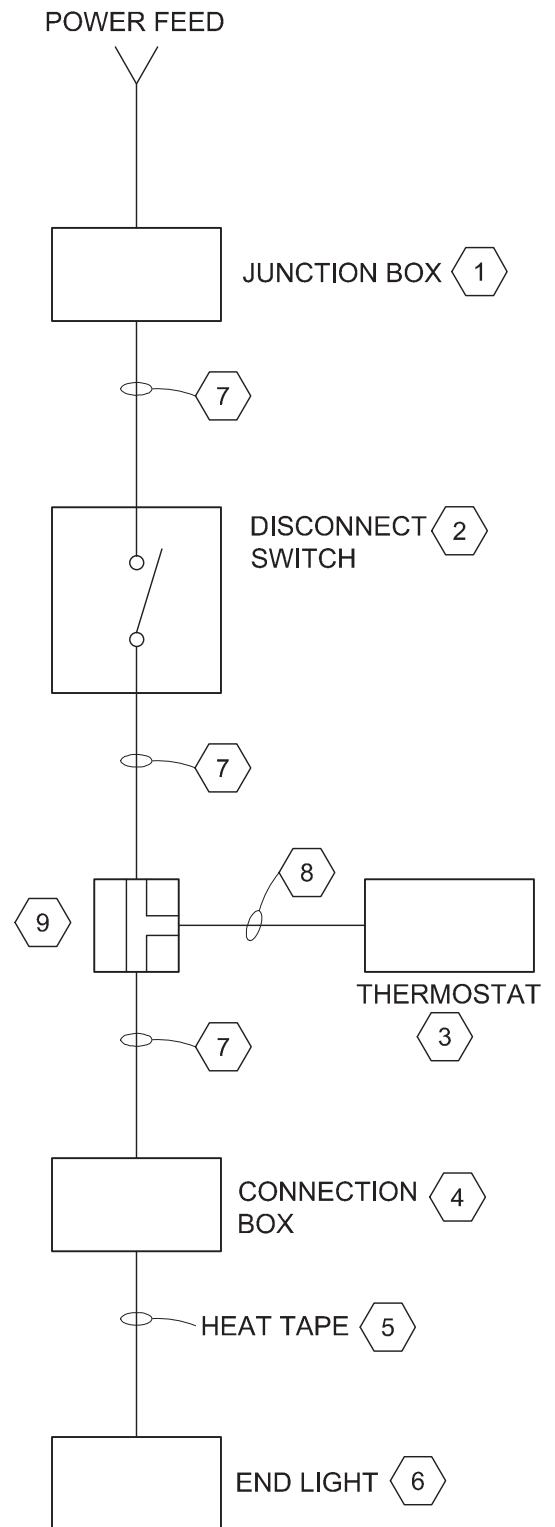

HEAT TRACE POWER ONE-LINE DETAIL



PARK CITY MUNICIPAL CORPORATION
WATER

DATE

3/2014

REV.

0

HEAT TAPE INSTALLATION FOR AIR RELEASE / CAV VALVE

STD. PLAN

575-B

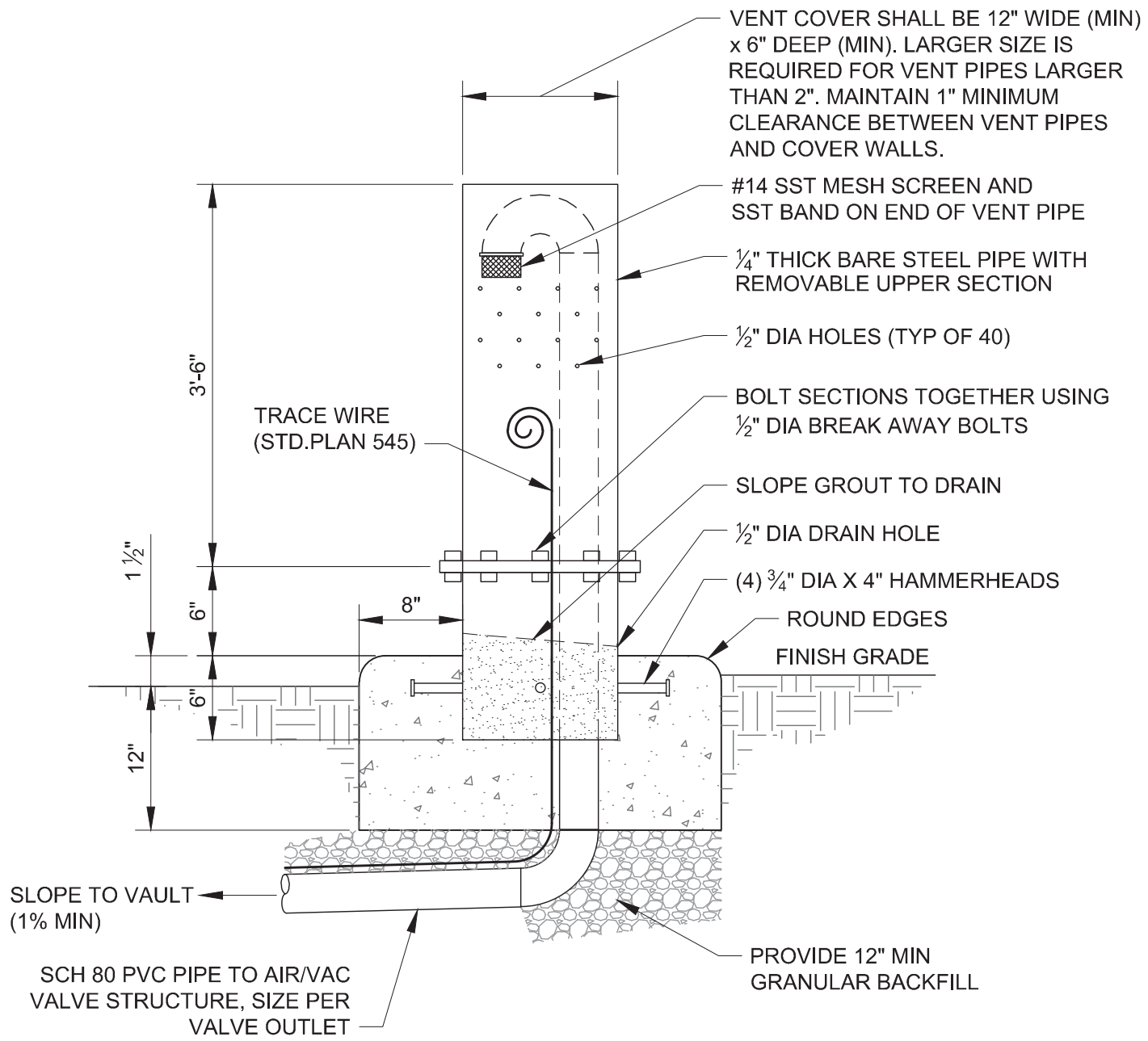

NOTES:

1. LOCATE VENT AS SHOWN ON APPROVED PLANS, 1'-6" MINIMUM BEHIND TOP BACK OF CURB / GUTTER OR SIDEWALK.

| | | | |
|--|--------|------------------------------|--------------|
|  PARK CITY MUNICIPAL CORPORATION WATER | DATE | <h2>AIR VENT STAND PIPE</h2> | STD. PLAN |
| | 3/2014 | | <h1>576</h1> |
| | REV. | | |
| | 0 | | |

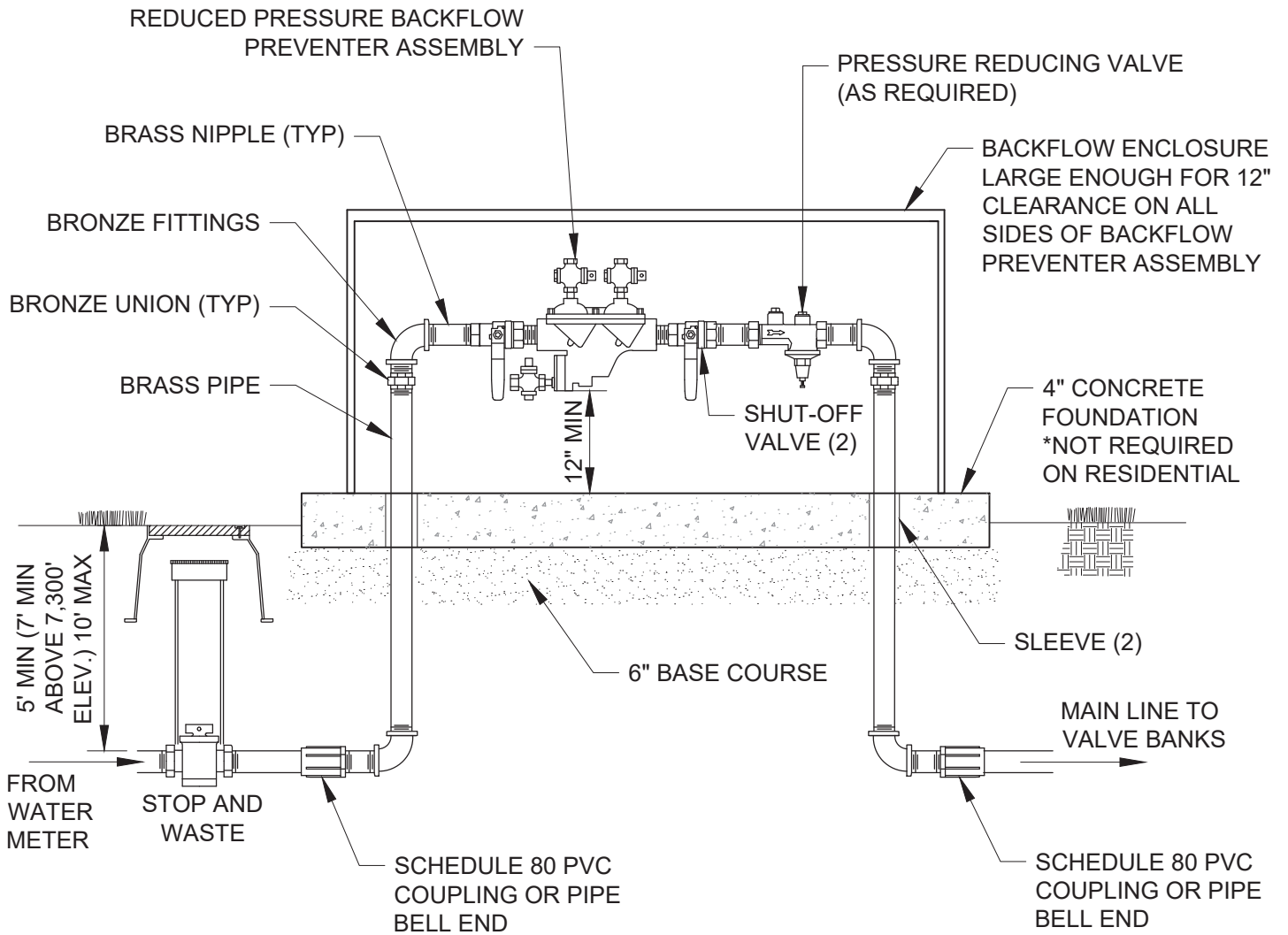

LESS THAN 3" DIAMETER



PARK CITY MUNICIPAL CORPORATION
WATER

DATE

03/2024

REV.

2

**CULINARY WATER - IRRIGATION
BACKFLOW PREVENTER**

STD. PLAN

577-A

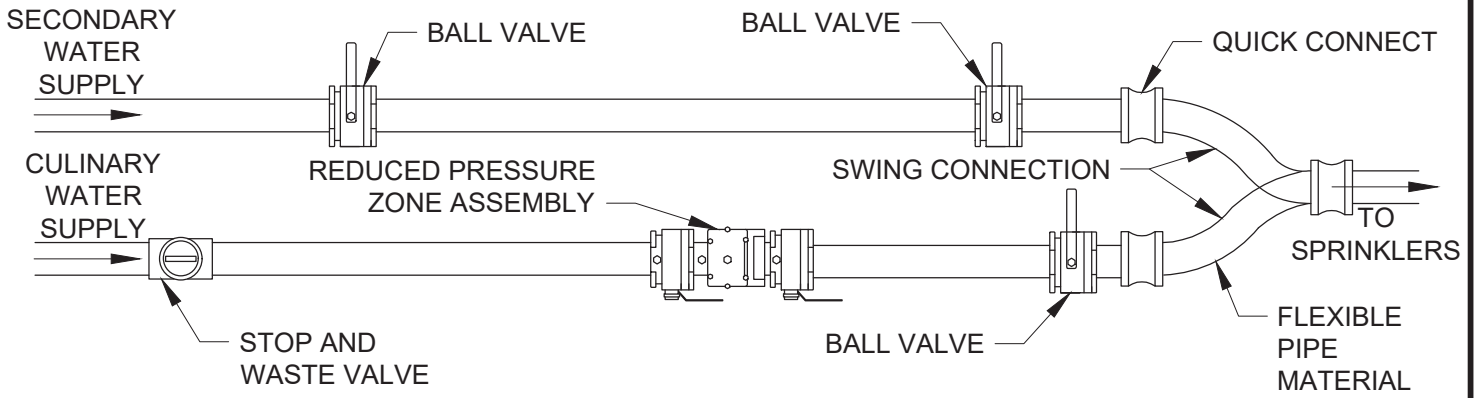

PLAN VIEW
NTS

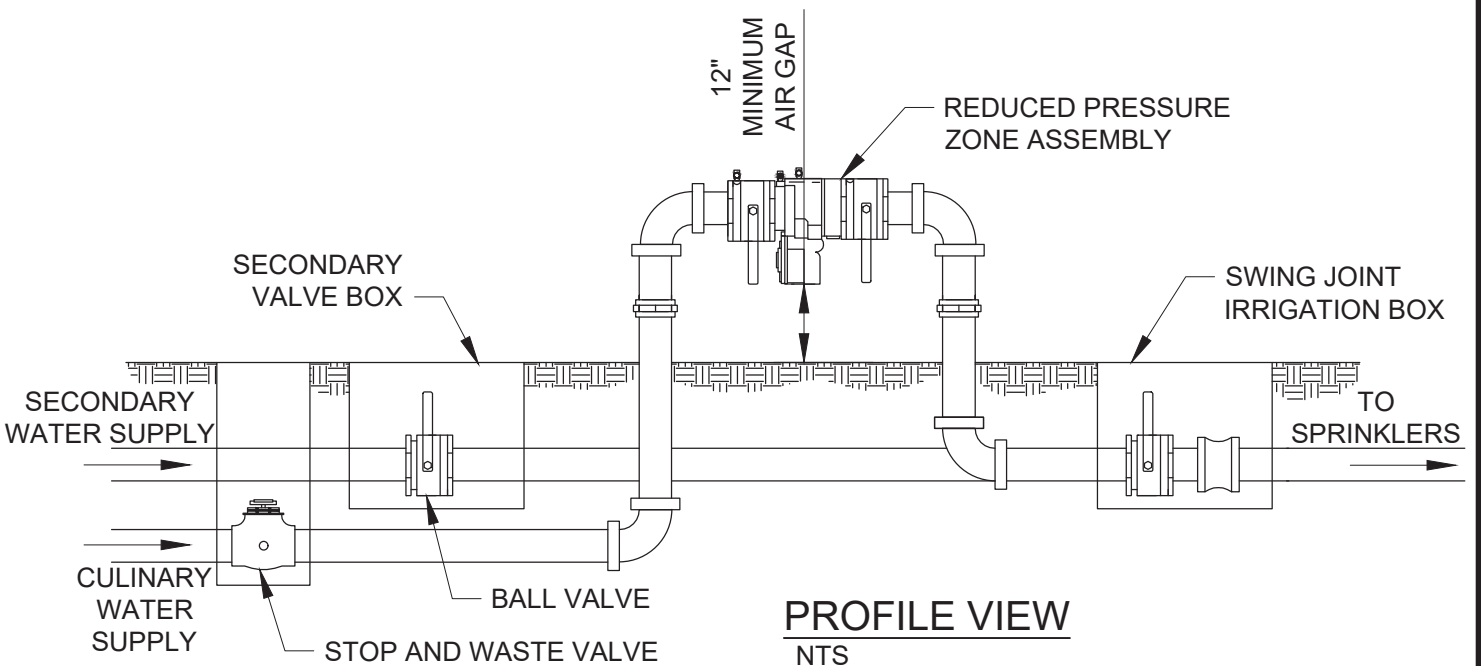

PROFILE VIEW
NTS

NOTES:

1. THE SWING CONNECTION IS INSTALLED SO THAT EITHER THE SECONDARY IRRIGATION WATER OR THE CULINARY WATER IS CONNECTED AND FEEDING THE SPRINKLER SYSTEM AT THE ONE TIME.
2. THE REDUCED PRESSURE ZONE ASSEMBLY MUST BE LOCATED AT A MINIMUM OF 12" FROM WALL, FENCE OR OTHER OBSTACLE.
3. THE REDUCED PRESSURE ZONE ASSEMBLY MUST BE LOCATED AT A MINIMUM OF 12" ABOVE GRADE (NOT ALLOWED IN A PIT BELOW GRADE).
4. THE REDUCED PRESSURE ZONE ASSEMBLY MUST BE INSPECTED BY A CERTIFIED BACKFLOW TECHNICIAN ON AN ANNUAL BASIS. CONSISTENT WITH PARK CITY MUNICIPAL CODE 13-1-29, BACKFLOW PREVENTER SHALL BE TESTED UPON INITIAL INSTALLATION AND EVERY 12 MONTHS THEREAFTER. PROOF OF TESTING/INSPECTION MUST BE PROVIDED TO PARK CITY EACH TIME. FAILURE TO PROVIDE PROOF OF TESTING MAY LEAD TO WATER SHUT-OFF TO PROTECT THE DRINKING WATER SYSTEM FROM POTENTIAL CONTAMINATION.



PARK CITY MUNICIPAL CORPORATION
WATER

DATE

03/2024

REV.

0

**CULINARY & SECONDARY
WATER - IRRIGATION SWING
CHECK CONNECTION**

STD. PLAN

577-B

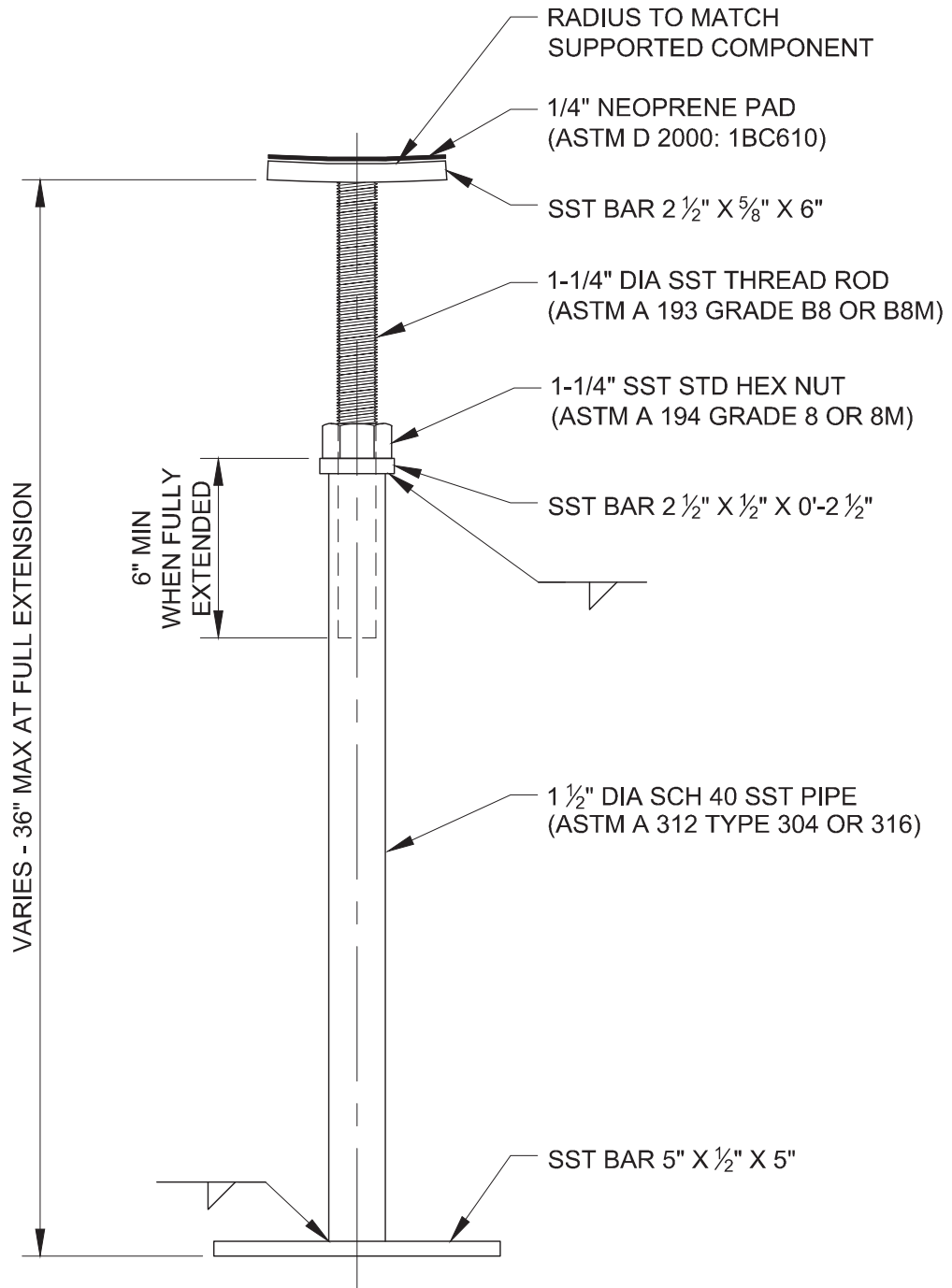

NOTES:

1. BAR MATERIAL TO BE ASTM A 240 TYPE 304 OR 316 (Fy= 30 KSI MIN.)

| | | | |
|--|--------|-----------------------|--------------|
|  PARK CITY MUNICIPAL CORPORATION WATER | DATE | <h2>PIPE SUPPORT</h2> | STD. PLAN |
| | 3/2014 | | <h1>578</h1> |
| | REV. | | |
| | 0 | | |