

**PCMC WATER SYSTEM – CORROSION PROTECTION REQUIREMENTS:**

PCMC HAS EXPERIENCED EXTERNAL CORROSION OF WATER DISTRIBUTION MATERIALS IN VARYING DEGREES THROUGHOUT THE CITY. TO MAXIMIZE THE LIFE CYCLE OF WATER SYSTEM IMPROVEMENTS, AS IMPACTED BY THE IMMEDIATE SITE CONDITIONS AND THE SELECTION OF MATERIALS, THE CITY HAS IDENTIFIED KEY DESIGN AND CONSTRUCTION REQUIREMENTS.

1. **FOR PROJECTS WITH LESS THAN 300 FEET OF NEW WATER PIPE** AND APPURTENANCES, CORROSION PROTECTION SHALL BE ADDRESSED IN THE FOLLOWING MANNER:
  - a. IN ADDITION TO THE REQUIRED POLYETHYLENE WRAP, APPLY A WAX TAPE COATING SYSTEM TO VALVE BONNET BOLTS, SADDLES, CORP STOPS, STAINLESS REPAIR CLAMPS AND ALL OTHER BURIED BOLTS, NUTS, CONNECTORS, RESTAINER GLAND BOLTS, AND COUPLING HARDWARE, AWWA C217. COATING SYSTEM TO INCLUDE A 4-MIL MINIMUM WAX TAPE PRIMER, FILLER MATERIAL, 45-MIL MINIMUM WAX TAPE AND PROTECTIVE OUTER WRAP. WHEN WAX TAPING A STAINLESS CLAMP THE ENTIRE CLAMP SHOULD BE WRAPPED NOT JUST BOLTS.
  - b. WAX TAPE COATING MATERIALS:
    - i. DENSO NORTH AMERICA DENSO PRIMER, DENSYL TAPE AND/OR MASTIC, DENSO FIBER-WRAP
    - ii. TRENTON PRIMER, #1 WAX-TAPE, AND GUARD-WRAP
    - iii. OR APPROVED EQUAL (SUBMITTAL TO CITY AND WRITTEN APPROVAL REQUIRED PRIOR TO INSTALLATION)
  
2. **FOR PROJECTS EXCEEDING 300 FEET OF NEW WATER PIPE** AND APPURTENANCES, CORROSION PROTECTION SHALL BE ADDRESSED IN THE FOLLOWING MANNER:
  - a. THE DEVELOPER AND ITS' DESIGN ENGINEER, GEOTECHNICAL ENGINEER, AND CORROSION CONSULTANT SHALL PROVIDE A SITE SPECIFIC "CORROSION STUDY REPORT". THE REPORT SHALL INCORPORATE PROJECT SPECIFIC FINDINGS INTO CORROSION PROTECTION RECOMMENDATIONS FOR THE PROPOSED WATER SYSTEM IMPROVEMENTS. THE REPORT SHALL INCLUDE AT A MINIMUM THE FOLLOWING ITEMS:
    - i. DETAILED INFORMATION ON EXISTING CONDITIONS, SOIL TYPES, CLASSIFICATION, ETC.
    - ii. IDENTIFICATION OF STRAY CURRENT SOURCES AND ANY EXISTING CORROSION PROTECTION SYSTEMS IN THE IMMEDIATE AREA
    - iii. IDENTIFICATION OF ANY POTENTIAL FOR HOT SPOTS OR VARYING SOIL CONDITIONS THAT MAY WARRANT CHANGES TO THE CORROSION PROTECTION PLAN DURING CONSTRUCTION.
    - iv. FIELD SAMPLING AND TESTING RESULTS WITHIN THE PROPOSED PIPE ZONE BASED ON REPRESENTATIVE SAMPLING OF THE DEVELOPMENT AREA CONDITIONS
    - v. SOIL RESISTIVITY TESTING RESULTS IDENTIFYING CORROSIVE SOIL CONDITIONS AND LOCATIONS (WENNER 4-PIN SOIL RESISTIVITY TESTS AND SOIL BOX RESISTIVITY TESTS) AT REPRESENTATIVE PIPE INSTALL DEPTHS
    - vi. LABORATORY ANALYSIS OF SOIL SAMPLES FOR PH, CHLORIDES, SULFATES, TOTAL SALTS, AND CONDUCTIVITY
    - vii. DETERMINATION OF THE NEED FOR CORROSION PROTECTION BASED ON SOIL CORROSIVITY CLASSIFICATION/SOIL RESISTIVITY AND RECOMMENDATION OF SUITABLE PIPE, CONSTRUCTION MATERIALS, PIPE PROTECTION METHOD, PIPE EXTERIOR COATINGS, ETC., BASED ON SITE CORROSIVITY. SEE TABLE BELOW.
    - viii. SPECIFY IF THE INVESTIGATION INCLUDES ONLY THE INITIAL PHASE OR ALL FUTURE PHASES

|  |             |   |                  |
|--|-------------|---|------------------|
| <br>PARK CITY MUNICIPAL CORPORATION<br><b>WATER</b> | <b>DATE</b> | <b>METALLIC PIPE<br/>CORROSION PROTECTION</b> | <b>STD. PLAN</b> |
|  | 10/2020     |   | <b>534.1</b>     |
|  | <b>REV.</b> |   |                  |
|  | 1           |   |                  |

- b. FOLLOWING PCMC'S RECEIPT AND REVIEW OF THE CORROSION STUDY REPORT, THE DEVELOPER WILL BE NOTIFIED OF THE CITY'S DETERMINATION AS TO REQUIRED PROTECTION OR THE DESIGN TEAM WILL BE REQUESTED TO MEET AND REVIEW THE FINDINGS AND ESTABLISH THE FINAL WATER SYSTEM DESIGN CRITERIA. THE CITY'S REVIEW WILL BE BASED ON THE FOLLOWING TABLE 1:

**TABLE 1 - SOIL CORROSIVITY CLASSIFICATION VERSUS SOIL RESISTIVITY**

| CORROSIVITY          | RESISTIVITY, OHM-CM | TREATMENT  |
|----------------------|---------------------|--|
| EXTREMELY CORROSIVE  | LESS THAN 1,000     | SITE SPECIFIC DESIGN REQUIRED  |
| VERY CORROSIVE       | 1,000 TO 3,000      | SITE SPECIFIC DESIGN REQUIRED  |
| CORROSIVE            | 3,000 TO 6,000      | NON-METALLIC PIPE – WAX TAPE COATING SYSTEM ON BOLTS & NUTS, ANODE PROTECTED FITTINGS AND VALVES                             |
| MODERATELY CORROSIVE | 6,000 TO 10,000     | NON-METALLIC PIPE - WAX TAPE COATING SYSTEM ON BOLTS AND NUTS ON PIPE, FITTINGS, AND VALVES                                  |
| MILDLY CORROSIVE     | MORE THAN 10,000    | WAX TAPE COATING SYSTEM ON BOLTS AND NUTS ON PIPE, FITTINGS, AND VALVES<br>*ALWAYS REQUIRED UNLESS SOILS TESTING IS PROVIDED |

- c. REFER TO PERTINENT PCMC WATER STANDARD PLANS OR PROVIDE CONSTRUCTION DRAWING DETAILS ASSOCIATED WITH CORROSION STUDY RECOMMENDATIONS AND THE PCMC FINAL APPROVED WATER SYSTEM

**WAX TAPE INSTALLATION PROCEDURES**

WIRE BRUSH AND SCRAPE THE SURFACE CLEAN OF DIRT, LOOSE COATING AND LOOSE RUST. APPLY A THIN FILM OF WAX-TAPE® PRIMER. IF THE SURFACE IS WET, COLD OR RUSTY, RUB AND PRESS ON PRIMER TO DISPLACE MOISTURE AND ENSURE ADHESION. THEN WRAP WAX-TAPE WRAP USING A 1" OVERLAP. ON STRAIGHT PIPE APPLY SLIGHT TENSION TO ENSURE CONTACT WITH SURFACE. ON IRREGULAR SURFACES ALLOW SLACK SO THE WRAP CAN BE MOLDED INTO CONFORMITY. IN EITHER CASE, PRESS AND FORM THE WRAP SO THERE ARE NO AIR POCKETS OR VOIDS UNDER THE WRAP. ALSO, PRESS AND SMOOTH OUT THE LAP SEAMS TO ENSURE THEY ARE SEALED AND APPLY OUTERWRAP. THE WRAP DOES NOT REQUIRE CURING OR DRYING TIME SO IT CAN BE BACKFILLED IMMEDIATELY.

|  |             |   |                  |
|--|-------------|---|------------------|
| <br>PARK CITY MUNICIPAL CORPORATION<br><b>WATER</b> | <b>DATE</b> | <b>METALLIC PIPE<br/>CORROSION PROTECTION</b> | <b>STD. PLAN</b> |
|  | 10/2020     |   | <b>534.2</b>     |
|  | <b>REV.</b> |   |                  |
|  | 1           |   |                  |

# TERMINAL BOARD WIRING DIAGRAM

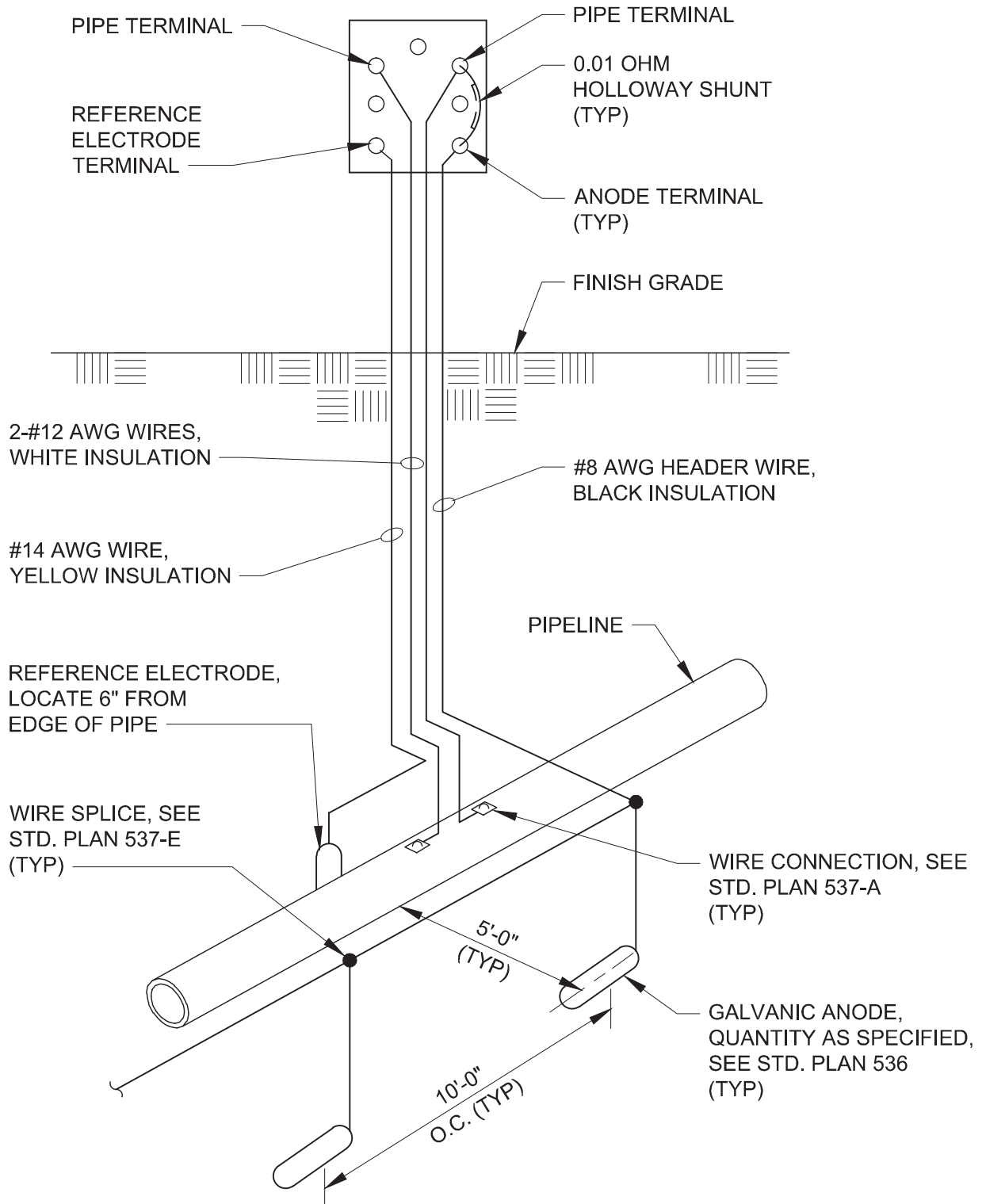

|  |         |                            |              |
|--|---------|----------------------------|--------------|
| <br>PARK CITY MUNICIPAL CORPORATION<br><b>WATER</b> | DATE    | <b>TYPE A TEST STATION</b> | STD. PLAN    |
|  | 12/2013 |                            | <b>535-A</b> |
|  | REV.    |                            |              |
|  | 0       |                            |              |

# TERMINAL BOARD WIRING DIAGRAM

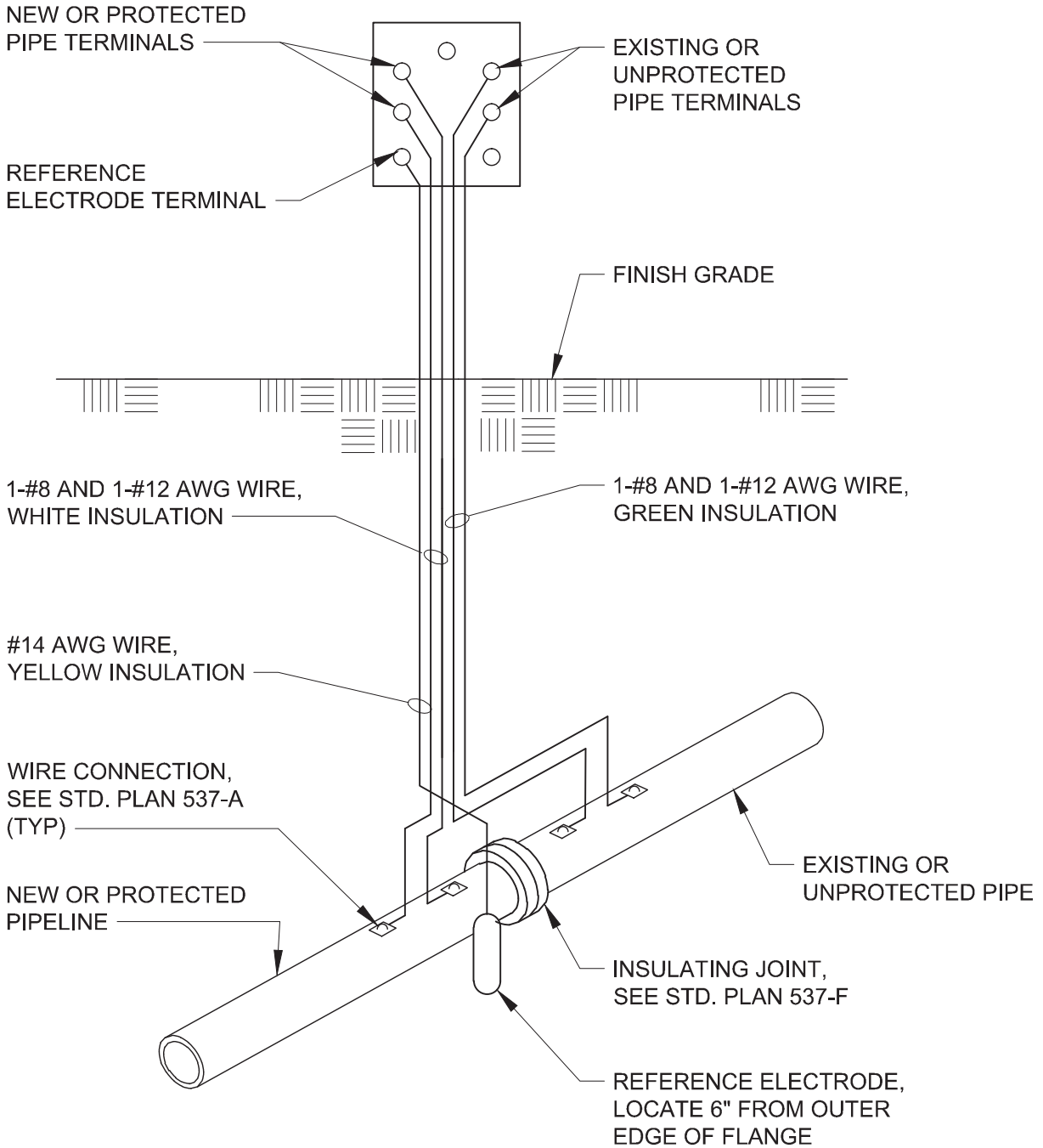

**NOTE:**  
SEE POST OR FLUSH MOUNTED TEST STATION DETAILS AS APPLICABLE FOR TEST STATION STYLE REQUIRED.

|  |         |                            |              |
|--|---------|----------------------------|--------------|
| <br>PARK CITY MUNICIPAL CORPORATION<br><b>WATER</b> | DATE    | <b>TYPE I TEST STATION</b> | STD. PLAN    |
|  | 12/2013 |                            | <b>535-B</b> |
|  | REV.    |                            |              |
|  | 0       |                            |              |

# TERMINAL BOARD WIRING DIAGRAM

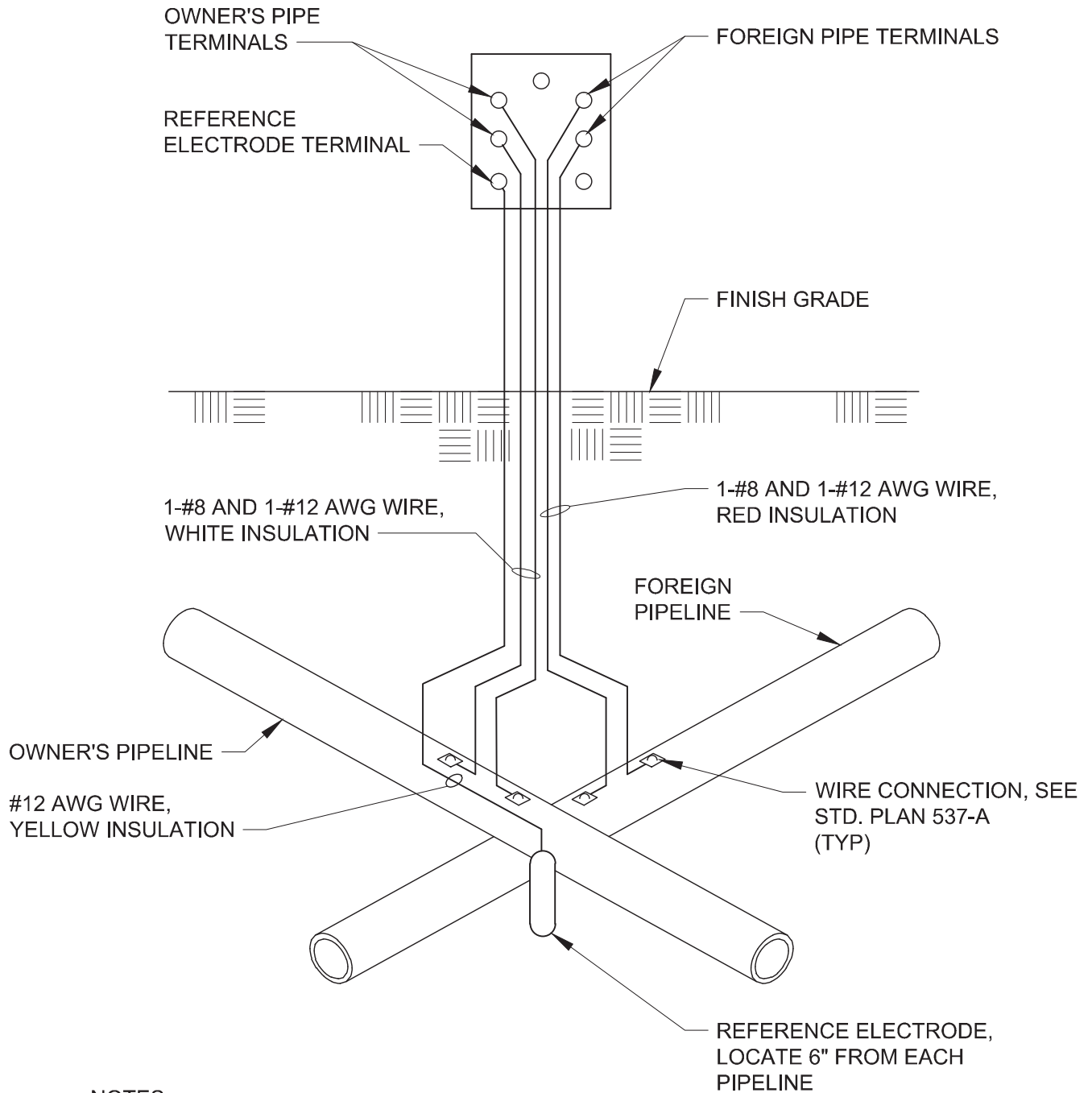

**NOTES:**

1. PRIOR TO MAKING WIRE CONNECTIONS CONTACT FOREIGN PIPELINE OWNER FOR APPROVAL.
2. SEE POST OR FLUSH MOUNTED TEST STATION DETAILS AS APPLICABLE FOR TEST STATION STYLE REQUIRED.

|  |         |                            |              |
|--|---------|----------------------------|--------------|
| <br>PARK CITY MUNICIPAL CORPORATION<br><b>WATER</b> | DATE    | <b>TYPE F TEST STATION</b> | STD. PLAN    |
|  | 12/2013 |                            | <b>535-C</b> |
|  | REV.    |                            |              |
|  | 0       |                            |              |

# TERMINAL BOARD WIRING DIAGRAM

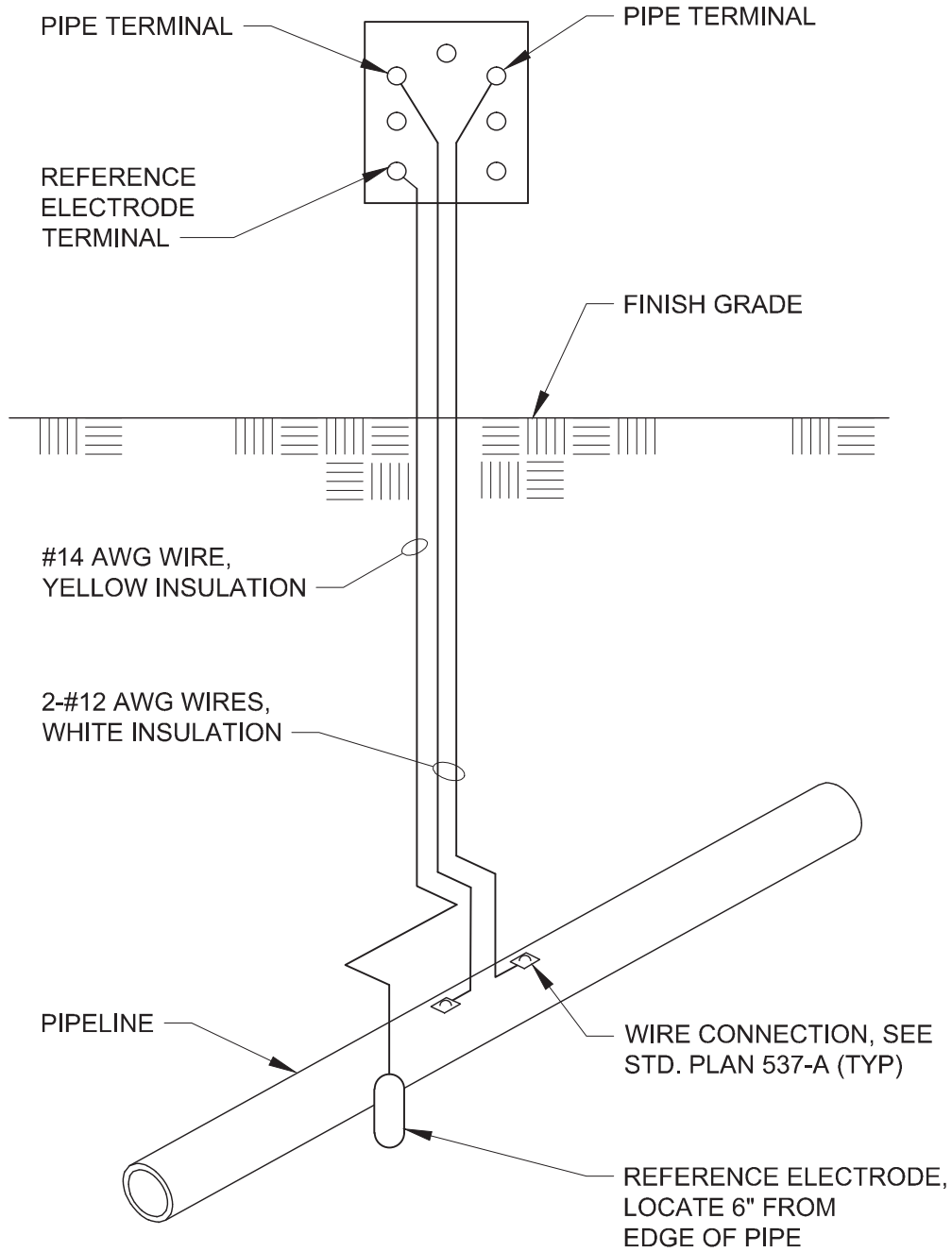

**NOTE:**  
SEE POST OR FLUSH MOUNTED TEST STATION DETAILS AS APPLICABLE FOR TEST STATION STYLE REQUIRED.



PARK CITY MUNICIPAL CORPORATION  
**WATER**

DATE

12/2013

REV.

0

**TYPE T TEST STATION**

STD. PLAN

**535-D**

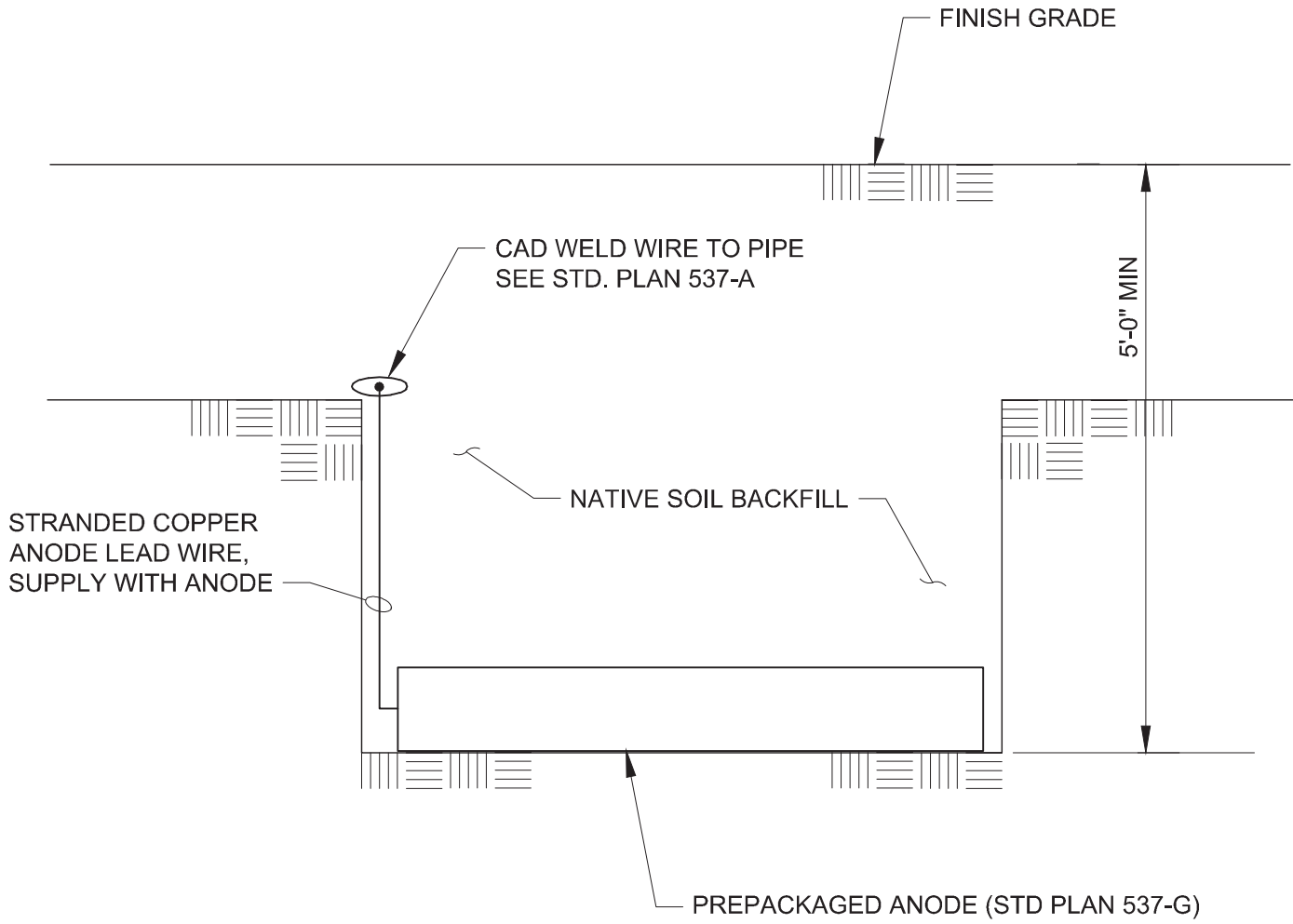

PARK CITY MUNICIPAL CORPORATION  
**WATER**

|         |
|---------|
| DATE    |
| 04/2014 |
| REV.    |
| 0       |

**HORIZONTAL GALVANIC  
 ANODE INSTALLATION  
 WITHOUT TEST STATION**

STD. PLAN

**536-A**

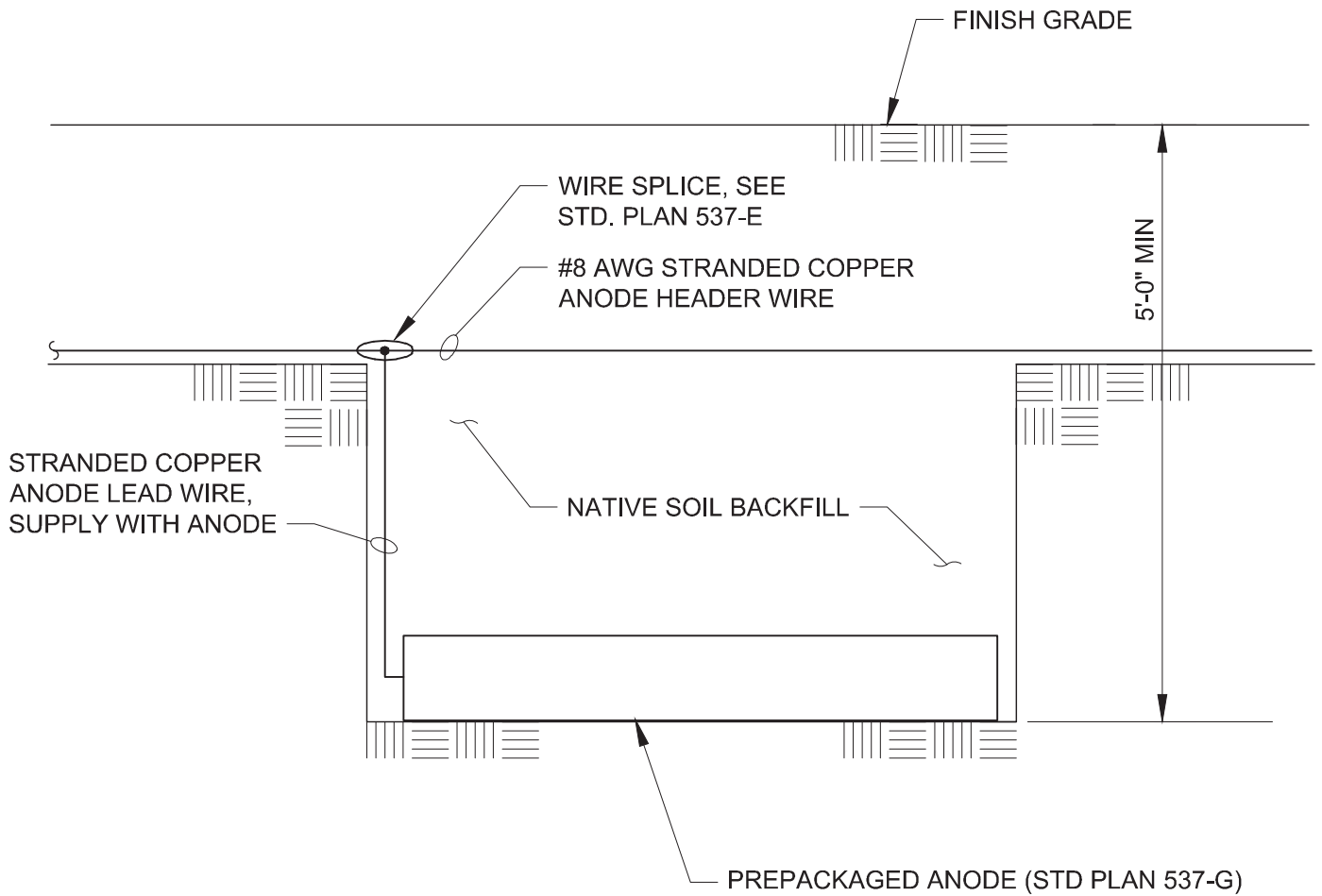

PARK CITY MUNICIPAL CORPORATION  
**WATER**

DATE

03/2014

REV.

0

## HORIZONTAL GALVANIC ANODE INSTALLATION

STD. PLAN

**536-B**



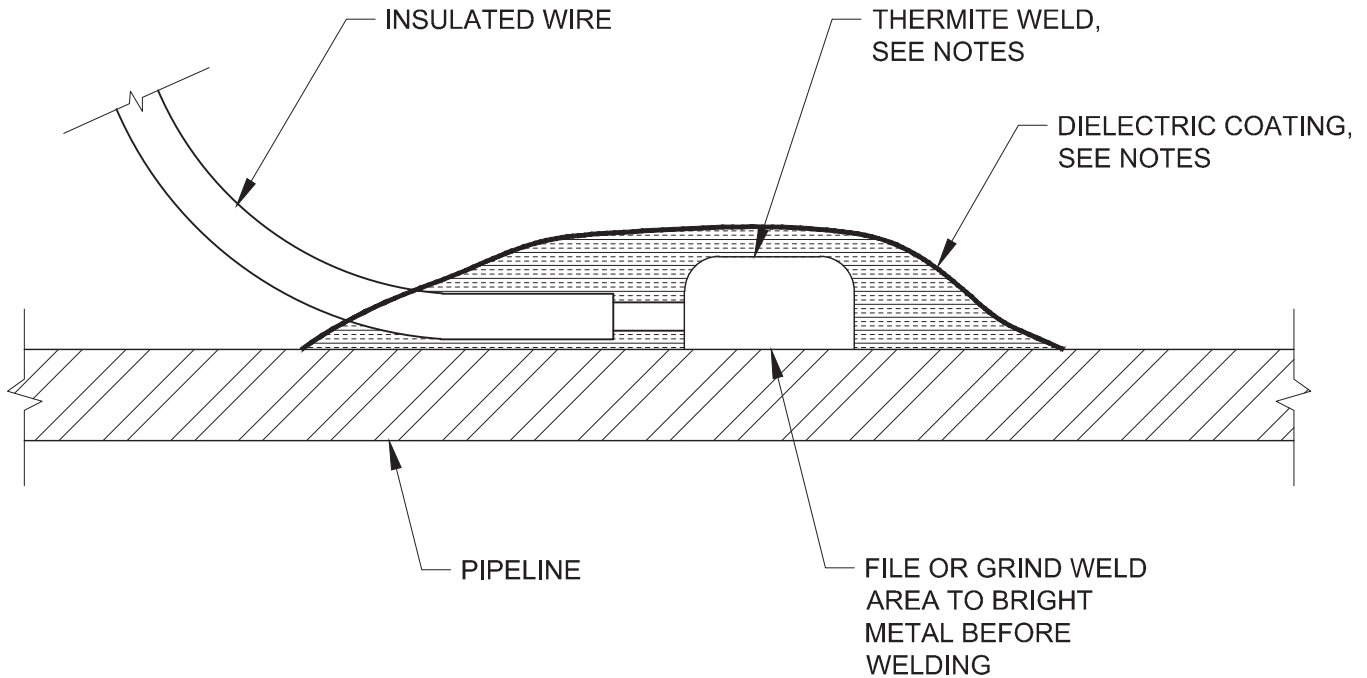

**NOTES:**

1. MAKE WIRE CONNECTION TO PIPE AT FIELD JOINT WHERE HOLDBACK OCCURS ON PIPELINE COATING.
2. MAINTAIN SEPARATION BETWEEN MULTIPLE TEST WIRE CONNECTIONS OF ONE PIPE DIA OR 24", WHICHEVER IS LESS.
3. COPPER SLEEVE REQUIRED FOR #2 AWG JOINT BONDS OR FOR #12 AWG OR SMALLER TEST WIRES.
4. WELDER AND CARTRIDGE SIZE VARIES ACCORDING TO PIPE SIZE AND PIPE MATERIAL, CONSULT WELDER MANUFACTURER FOR RECOMMENDED WELDER AND CARTRIDGE.
5. COAT COMPLETED CONNECTIONS, SEE STD PLAN 537-G.
6. PIPELINE JOINT COATING NOT SHOWN FOR CLARITY.



PARK CITY MUNICIPAL CORPORATION  
**WATER**

DATE

04/2014

REV.

0

**STEEL AND DUCTILE IRON PIPE  
WIRE CONNECTION**

STD. PLAN

**537-A**

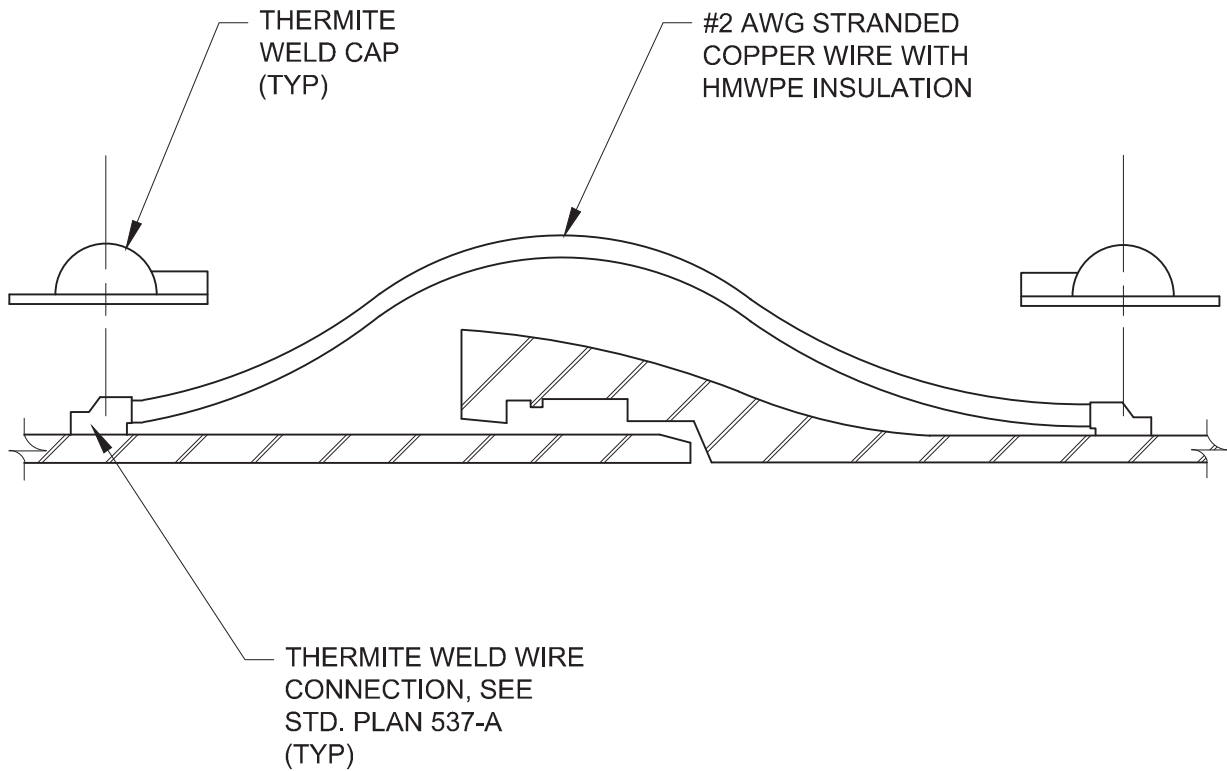

NOTES:

1. PUSH ON DUCTILE IRON BOND SHOWN, SIMILAR FOR DUCTILE MECHANICAL AND RESTRAINED JOINTS, AND STEEL CARNEGIE JOINTS.
2. INSTALL 2 BOND WIRES AT EACH PIPE JOINT, UNLESS SPECIFIED OTHERWISE.
3. COAT THERMITE WELDS WITH THERMITE WELD CAP OR FAST CURE EPOXY AT CONTRACTOR'S OPTION.



PARK CITY MUNICIPAL CORPORATION  
**WATER**

DATE

12/2013

REV.

0

**DUCTILE IRON PIPE  
JOINT BOND**

STD. PLAN

**537-B**

#2 AWG STRANDED  
WIRE, HMWPE  
INSULATION

#12 AWG STRANDED  
WIRE PIGTAIL, THHN  
INSULATION (TYP OF 2)

THERMITE WELD, SEE  
STD. PLAN 537-A  
(TYP)

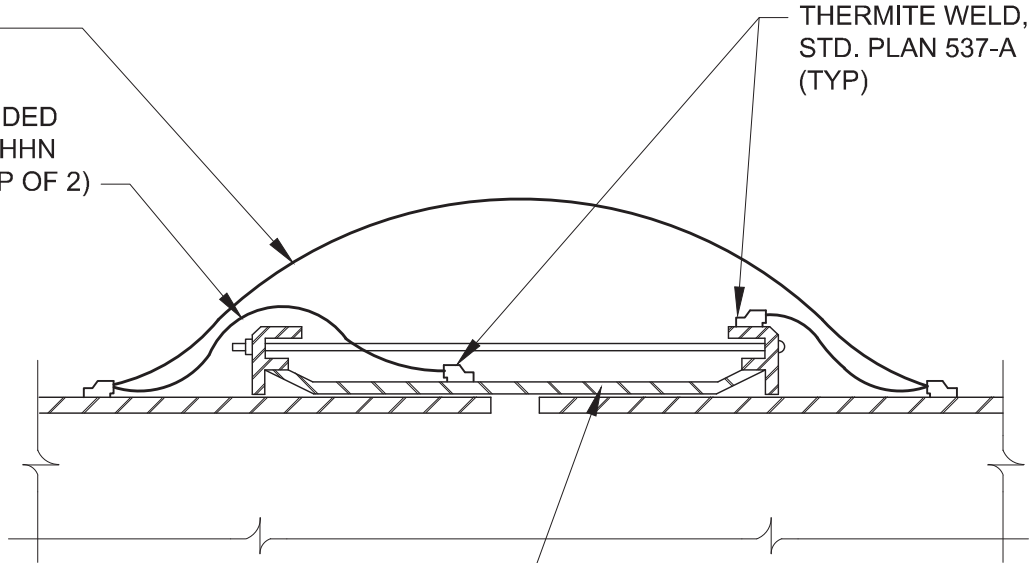

FLEXIBLE,  
EXPANSION, OR  
DEPEND-O-LOCK  
TYPE COUPLING



PARK CITY MUNICIPAL CORPORATION  
**WATER**

DATE

12/2013

REV.

0

## FLEXIBLE JOINT BOND

STD. PLAN

# 537-C

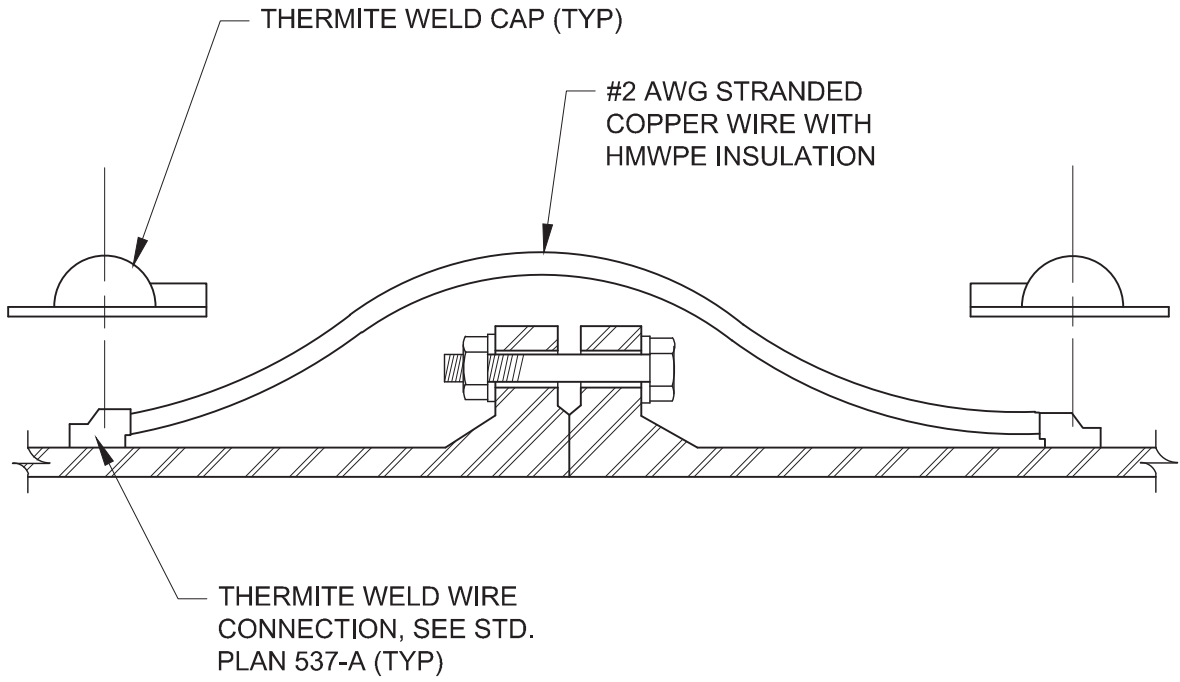

NOTE:  
INSTALL TWO BOND WIRES AT EACH PIPE JOINT.



PARK CITY MUNICIPAL CORPORATION  
**WATER**

DATE

12/2013

REV.

0

**FLANGED AND MECHANICAL  
JOINT BOND**

STD. PLAN

**537-D**

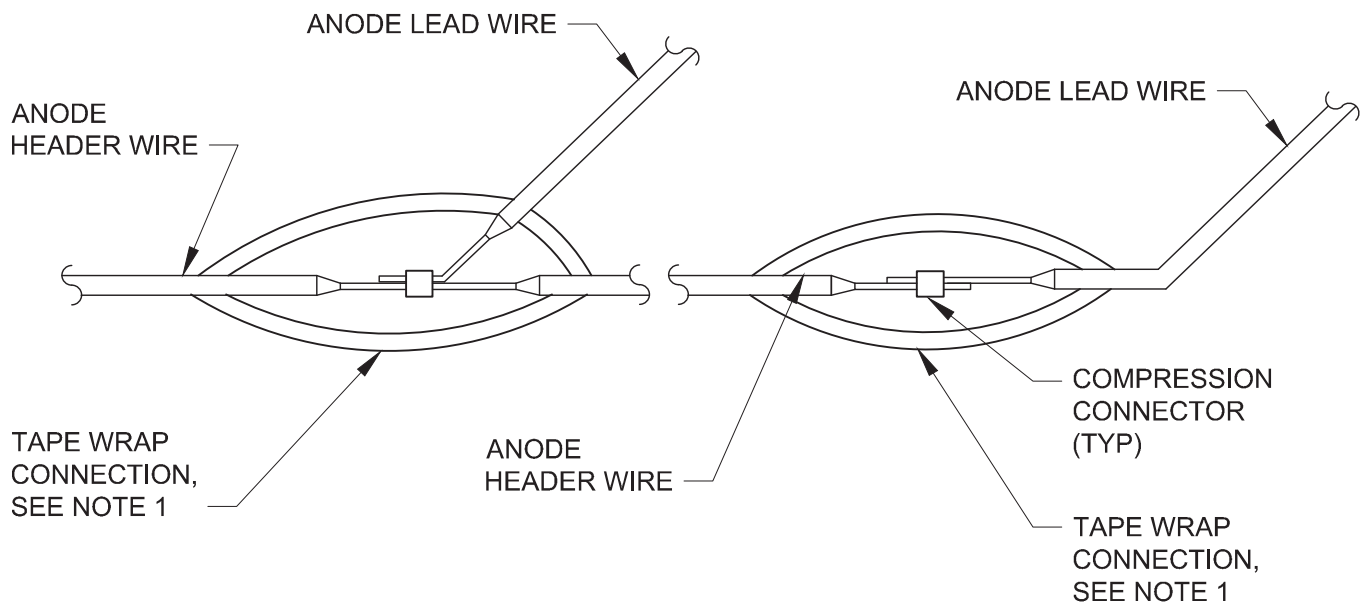

**NOTES:**

1. FILL VOIDS AND IRREGULARITIES WITH INSULATING PUTTY, WRAP CONNECTION WITH TWO LAYERS OF SCOTCH 130C SELF VULCANIZING RUBBER TAPE AND TWO LAYERS OF SCOTCH 88 VINYL ELECTRICAL TAPE.
2. DETAIL SIMILAR FOR ANODE HEADER WIRE SPLICES, SIZE COMPRESSION CONNECTORS AS REQUIRED.



PARK CITY MUNICIPAL CORPORATION  
**WATER**

DATE

12/2013

REV.

0

**GALVANIC ANODE  
WIRE SPLICE**

STD. PLAN

**537-E**

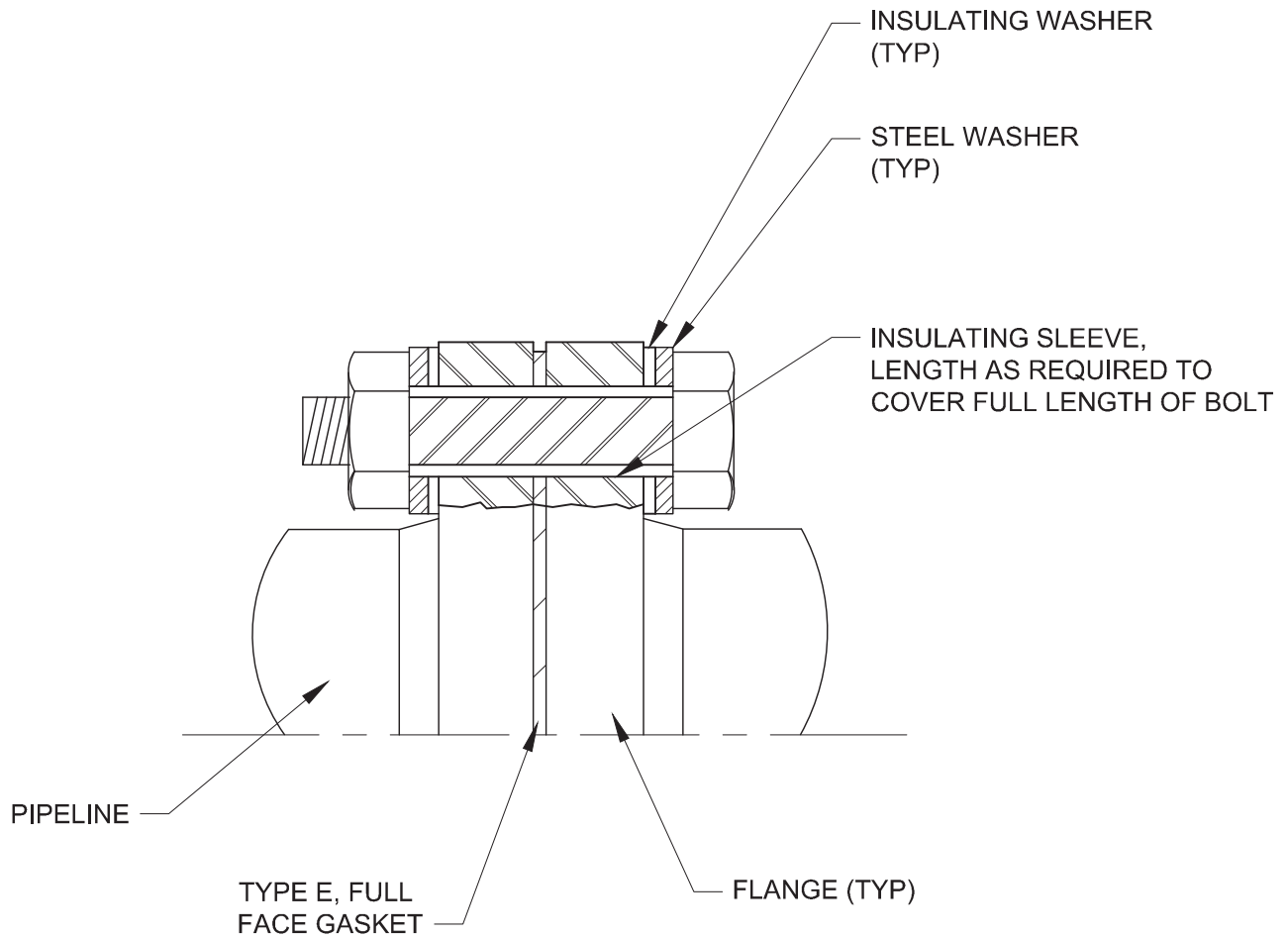

NOTES:

1. DOUBLE INSULATING WASHERS SHOWN FOR NON-BURIED INSULATING FLANGE INSTALLATIONS.
2. FOR BURIED OR SUBMERGED INSULATING FLANGE INSTALLATION USE SINGLE INSULATING WASHER ON UNPROTECTED SIDE OF INSULATING FLANGE.
3. COAT INTERIOR OF MORTAR LINED PIPE FOR TWO PIPE DIAMETERS WITH NSF APPROVED EPOXY AT 20 MILS DFT.
4. COAT BURIED OR IMMERSSED INSULATING FLANGES WITH SPECIFIED PIPELINE DIELECTRIC JOINT COATING OR HEAT SHRINK SLEEVE WITH MORTAR OVERCOAT ON MLC STEEL PIPE.
5. TEST COMPLETED JOINT FOR ELECTRICAL ISOLATION AND REPAIR AS REQUIRED.



PARK CITY MUNICIPAL CORPORATION  
**WATER**

DATE

12/2013

REV.

0

**INSULATING FLANGE**

STD. PLAN

**537-F**

SINGLE UNRESTRAINED  
FITTING OR JOINT  
RESTRAINT ASSEMBLY

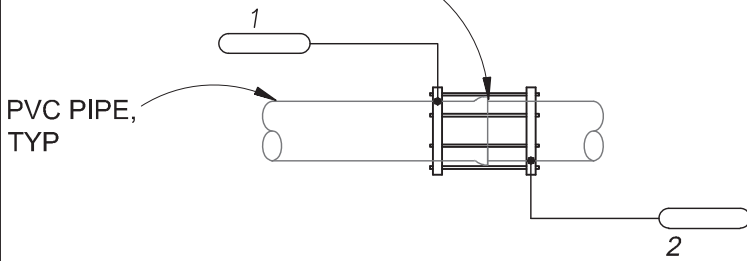

DETAIL A

**LEGEND**

- THERMITE WELD
- ANODE-SEE NOTES 2 THROUGH 8
- ⌒ #2 AWG BOND WIRE
- ⌒ #8 AWG BOND WIRE

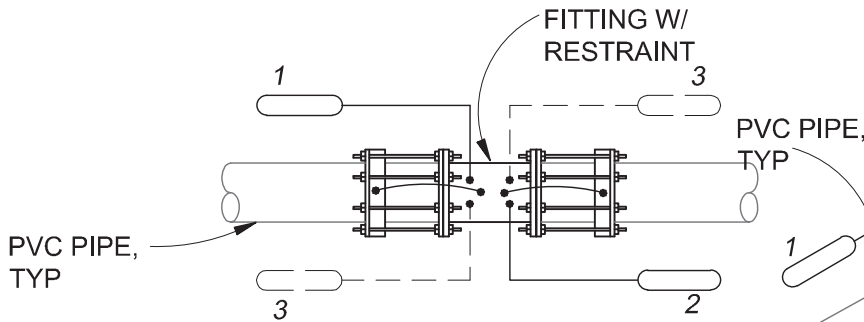

DETAIL B

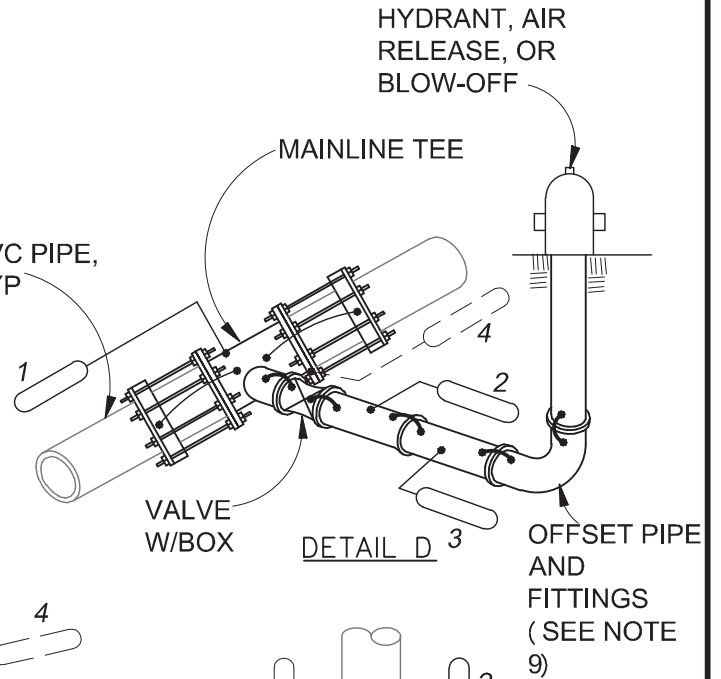

DETAIL D

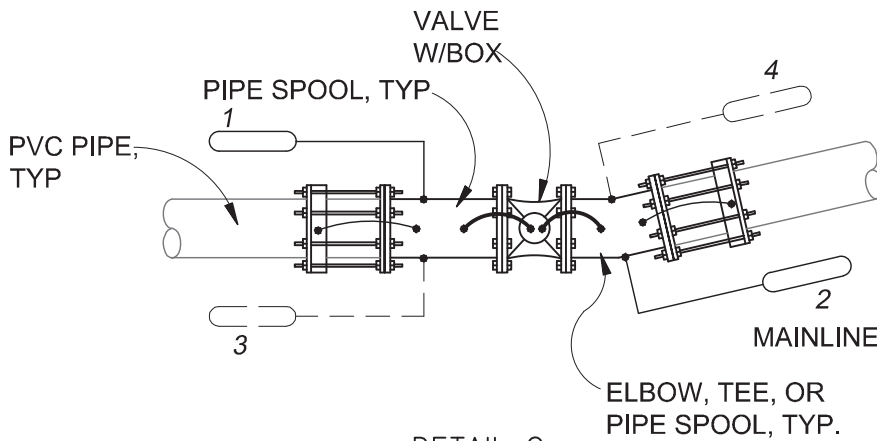

DETAIL C

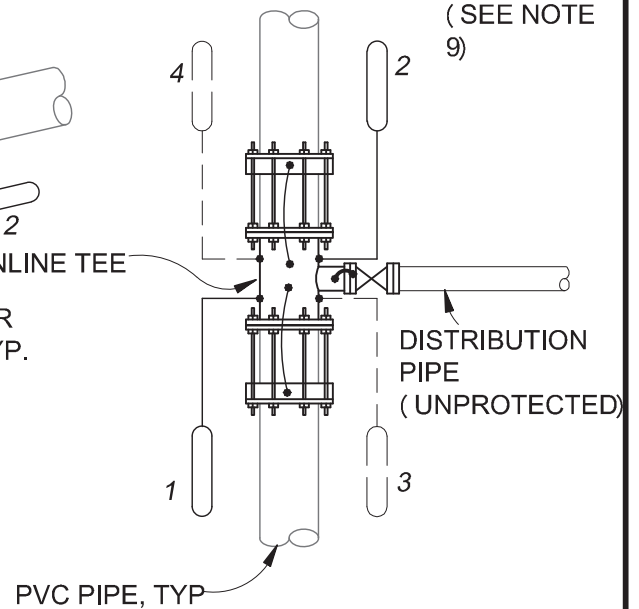

DETAIL E



PARK CITY MUNICIPAL CORPORATION  
WATER

DATE

4/2014

REV.

0

**METALLIC PIPE  
APPURTENANCE AND  
FITTING CATHODIC  
PROTECTION**

STD. PLAN

**537-G.1**

NOTES:

1. APPLY DIELECTRIC COATING TO ALL METALLIC FITTINGS, VALVES, PIPE, AND VALVE BOXES UNLESS SPECIFIED OTHERWISE.
2. GALVANIC ANODES SHALL BE H1 ALLOY MAGNESIUM ANODES AT THE BARE WEIGHT LISTED IN THE SCHEDULE, SUPPLY PREPACKAGED IN A CLOTH BAG AT 2.5 TIMES BARE WEIGHT IN 75% GYPSUM, 20% BENTONITE, AND 5% SODIUM SULFATE BACKFILL WITH MANUFACTURER'S STANDARD 10-FOOT LONG, NO. 12 AWG LEAD WIRE.
3. INSTALL ANODES IN PIPE TRENCH APPROXIMATELY 2 FEET FROM THE FITTING WHERE POSSIBLE, BUT NOT CLOSER THAN 12-INCHES FROM THE METALLIC FITTING.
4. ANODE PLACEMENT IS INDICATED BY NUMBER NEXT TO EACH ANODE SHOWN IN DETAILS, FIRST ANODE IS PLACED AT ONE, SECOND AT TWO, ETC.
5. LOCATE MULTIPLE ANODES AT EQUAL SPACING ALONG PIPE FITTING ASSEMBLY AND ON OPPOSITE SIDES OF PIPE WHEN MORE THAN FOUR ANODES ARE REQUIRED.
6. 32-LB GALVANIC ANODES MAY BE SUBSTITUTED FOR 17-LB ANODES AT THE CONTRACTOR'S OPTION, BUT THE TOTAL QUANTITY OF ANODES REQUIRED WILL NOT CHANGE.
7. ANODE QUANTITY AND BARE WEIGHT REQUIRED FOR SOME PIPE AND FITTING COMBINATIONS ARE LISTED IN THE SCHEDULE.
8. ADDITIONAL ANODES ARE REQUIRED ON METALLIC PIPE ASSEMBLIES THAT EXCEED THE MAXIMUM COMBINED LENGTH LISTED IN THE SCHEDULE FOR ALL FITTINGS, VALVES, PIPE SPOOLS, AND OTHER METALLIC APPURTENANCES IN THE ASSEMBLY, EXCLUDING THRUST RESTRAINT, ADD ONE ANODE FOR EACH EXTRA PIPE LENGTH AND ONE ANODE FOR FRACTIONAL EXTRA PIPE LENGTH TO THE LISTED QUANTITY OF ANODES.
9. PIPE ASSEMBLIES FOR BLOW-OFFS, AIR RELEASE, AND FIRE HYDRANTS ARE BASED ON STANDARD CONSTRUCTION DETAILS AND INCLUDES ONE RESTRAINED MAINLINE TEE FITTING AND ALL OFFSET PIPE, FITTINGS, AND RISERS AS SHOWN ON THE APPLICABLE CONSTRUCTION DETAILS, ADDITIONAL ANODES ARE REQUIRED FOR - 1) OFFSET PIPE LENGTH IN EXCESS OF THE MAXIMUM COMBINED LENGTH FOR THE OFFSET PIPE DIAMETER, AND 2) ADDITIONAL ANODES REQUIRED FOR EXTRA MAINLINE PIPE FITTINGS.
10. BOND ALL ADJACENT FITTING JOINTS WHERE MULTIPLE METALLIC FITTINGS ARE INSTALLED TOGETHER WITH JOINT BONDS AS SHOWN IN DETAIL 711-L,M,N.
11. BOND WIRES SHALL BE STRANDED COPPER WIRE WITH THHN INSULATION, USE NO. 2 AWG WIRE FOR BONDING OF PIPE OR FITTING JOINTS, USE NO. 8 AWG WIRE FOR BONDING FOLLOWER RINGS AND RESTRAINED JOINT RINGS TO FITTING AS SHOWN.
12. COAT ALL THERMITE WELDS, PIPE, AND EXPOSED COPPER WIRE WITH SCOTCHKOTE 206P THERMOPLASTIC PATCH MELT STICK COATING, THERMITE WELD CAP, OR COATING SYSTEM AS SPECIFIED.

|  |        |  |                |
|--|--------|--|----------------|
| <br>PARK CITY MUNICIPAL CORPORATION<br><b>WATER</b> | DATE   | <b>METALLIC PIPE<br/>         APPURTENANCE AND<br/>         FITTING CATHODIC<br/>         PROTECTION</b> | STD. PLAN      |
|  | 4/2014 |  | <b>537-G.2</b> |
|  | REV.   |  |                |
|  | 0      |  |                |



13. COATING MATERIAL FOR METALLIC PIPE AND FITTINGS

A. GENERAL:

1. ALL METALLIC FITTINGS AND METALLIC HARDWARE ASSOCIATED WITH NON-METALLIC PIPE CONSTRUCTION SHALL BE DIELECTRICALLY COATED WITH A BONDED COATING.
2. PREPARE SURFACE OF ITEMS TO BE COATED IN ACCORDANCE WITH COATING MANUFACTURER'S REQUIREMENTS.

B. DIELECTRIC COATING SYSTEMS FOR METALLIC PIPE, FITTINGS, AND APPURTENANCES

1. WAX TAPE COATING SYSTEM

- a. METALLIC PIPING, FITTINGS, AND APPURTENANCES SHALL BE COATED IN ACCORDANCE WITH AWWA C217.
- b. APPLY COATING SYSTEM TO ALL BURIED METALLIC PIPE APPURTENANCES, INCLUDING JOINTS, FITTINGS, BOLTS, AND IRREGULARLY SHAPED SURFACES.
- c. FILLER MATERIAL:
  - (1) SHALL BE COMPRISED OF SATURATED PETROLEUM HYDROCARBONS (PETROLATUM) INERT FILLERS, REINFORCING FIBERS AND THERMAL EXTENDERS. VARIATIONS MAY CONTAIN BEADS OF CELLULAR POLYMER AND FLOW CONTROL ADDITIVES.
  - (2) WAX SHALL BE COLD APPLIED SELF SUPPORTING MASTICS FOR MOLDING AROUND IRREGULAR SHAPED FITTINGS TO PROVIDE A SUITABLE PROFILE FOR APPLYING ANTI-CORROSION TAPES.
- d. TAPE COATING
  - (1) COMPOSED OF A NON-WOVEN SYNTHETIC FABRIC CARRIER, FULLY IMPREGNATED WITH A NEUTRAL COMPOUND BASED ON SATURATED PETROLEUM COMPOSED OF INERT SILICEOUS FILLERS. APPLY COATING IN ACCORDANCE WITH AWWA C217, EXCEPT AS MODIFIED HEREIN.
- e. PROTECTIVE OUTER WRAP
  - (1) PROVIDE FIBER MESH FABRIC OUTER WRAP OVER WAX TAPE RESIN COATED, WOVEN FIBER-MESH FABRIC THAT IS .005 INCHES.
- f. ALL COMPONENTS OF THE WAX TAPE COATING SYSTEM SHALL BE FROM A SINGLE MANUFACTURER AS MANUFACTURED BY DENSO NORTH AMERICAN, TRENTON, OR EQUAL.



PARK CITY MUNICIPAL CORPORATION  
WATER

DATE

4/2014

REV.

0

**METALLIC PIPE  
APPURTENANCE AND  
FITTING CATHODIC  
PROTECTION**

STD. PLAN

**537-G.3**

## SCHEDULE OF ANODE QUANTITIES AND BARE WEIGHT

| PIPE AND FITTINGS DESCRIPTIONS | MAX. COMBINED LENGTH | PIPELINE DIAMETER |         |         | REFERENCE DETAIL |
|--------------------------------|----------------------|-------------------|---------|---------|------------------|
|                                |                      | 6"-10"            | 12"-18" | 20"-24" |                  |
| ONE JOINT RESTRAINT            | 0'                   | 1 @ 17#           | 1 @ 17# | 1 @ 17# | A                |
| ONE FITTING W/O RESTRAINT      | 0'                   | 1 @ 17#           | 1 @ 17# | 1 @ 17# | A                |
| ONE FITTING W/ RESTRAINT       | 0'                   | 1 @ 17#           | 1 @ 17# | 1 @ 17# | B                |
| ONE FLEXIBLE COUPLING          | 0'                   | 1 @ 17#           | 1 @ 17# | 1 @ 17# | A                |
| 3"-6" AIR RELEASE ASSEMBLY     | 20'                  | 2 @ 17#           | 3 @ 17# | 4 @ 17# | D                |
| 6" BLOW-OFF PIPE ASSEMBLY      | 20'                  | 2 @ 17#           | 3 @ 17# | 4 @ 17# | D                |
| 6" OR 8" FIRE HYDRANT          | 20'                  | 2 @ 17#           | 3 @ 17# | 4 @ 17# | D                |
| BURIED MAINLINE VALVE          | 10'                  | 1 @ 17#           | 1 @ 17# | 2 @ 17# | C                |
| MULTIPLE FITTINGS              | 10'                  | 1 @ 17#           | 2 @ 17# | 2 @ 17# | C                |
| VALVED TURNOUT                 | 0'                   | 1 @ 17#           | 2 @ 17# | 2 @ 17# | E                |
| <u>EXTRA PIPE LENGTH:</u>      |                      |                   |         |         |                  |
| 1-17 LB ANODE FOR              |                      | 30 FT             | 15 FT   | 10 FT   |                  |
| <u>EXTRA FITTING LENGTH:</u>   |                      |                   |         |         |                  |
| 2-17 LB ANODES FOR             |                      | 20 FT             | 12 FT   | 8 FT    |                  |



PARK CITY MUNICIPAL CORPORATION  
**WATER**

DATE

4/2014

REV.

0

### METALLIC PIPE APPURTENANCE AND FITTING CATHODIC PROTECTION

STD. PLAN

## 537-G.4

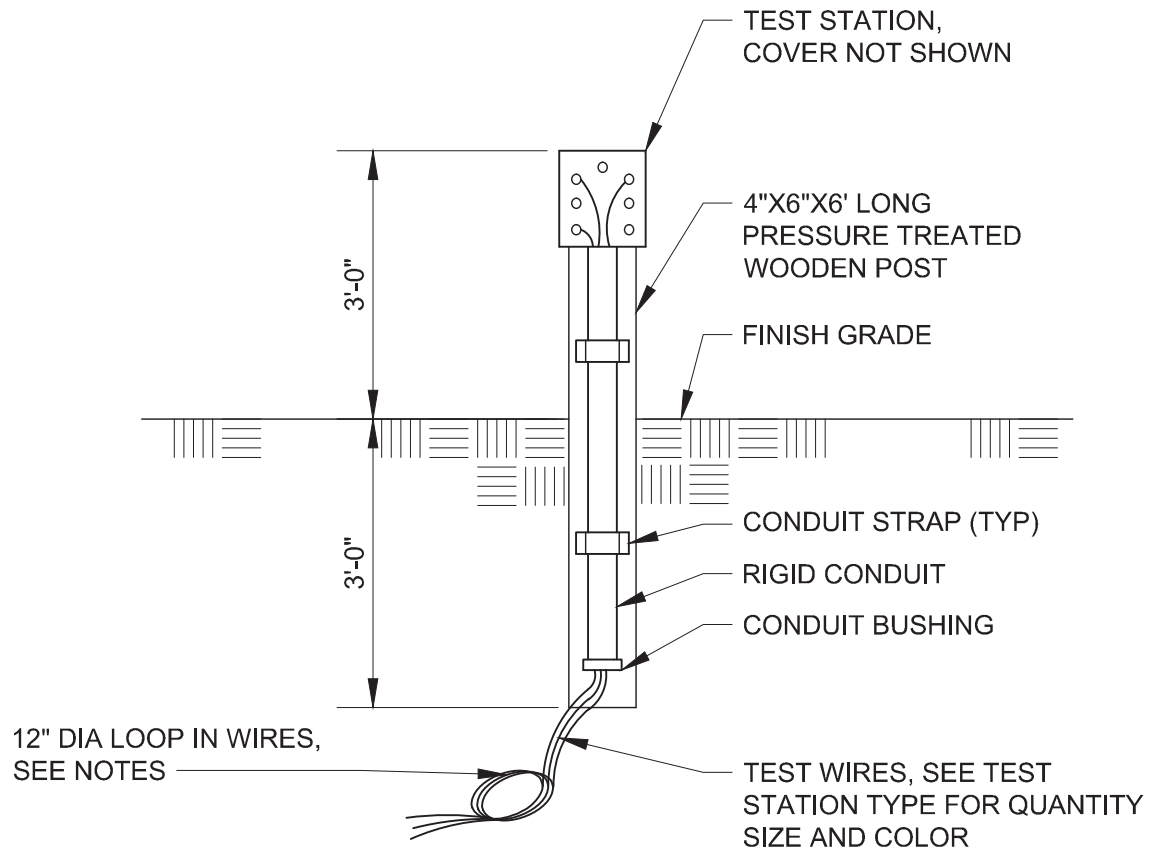

NOTES:

1. TEST STATION TO BE ALUMINUM BODY AND LID WITH THREADED CONNECTION FOR CONDUIT.
2. QUANTITY OF TERMINALS AND WIRING CONNECTIONS VARIES, SEE APPLICABLE TEST STATION DETAILS FOR TYPE OF TEST STATION.
3. PROVIDE WIRE LOP AT BASE OF POST MOUNTED TEST STATION TO MINIMIZE SETTLEMENT STRESSES ON WIRE.



PARK CITY MUNICIPAL CORPORATION  
**WATER**

DATE

03/2014

REV.

0

**POST STYLE TEST STATION  
WOOD**

STD. PLAN

**538-A**

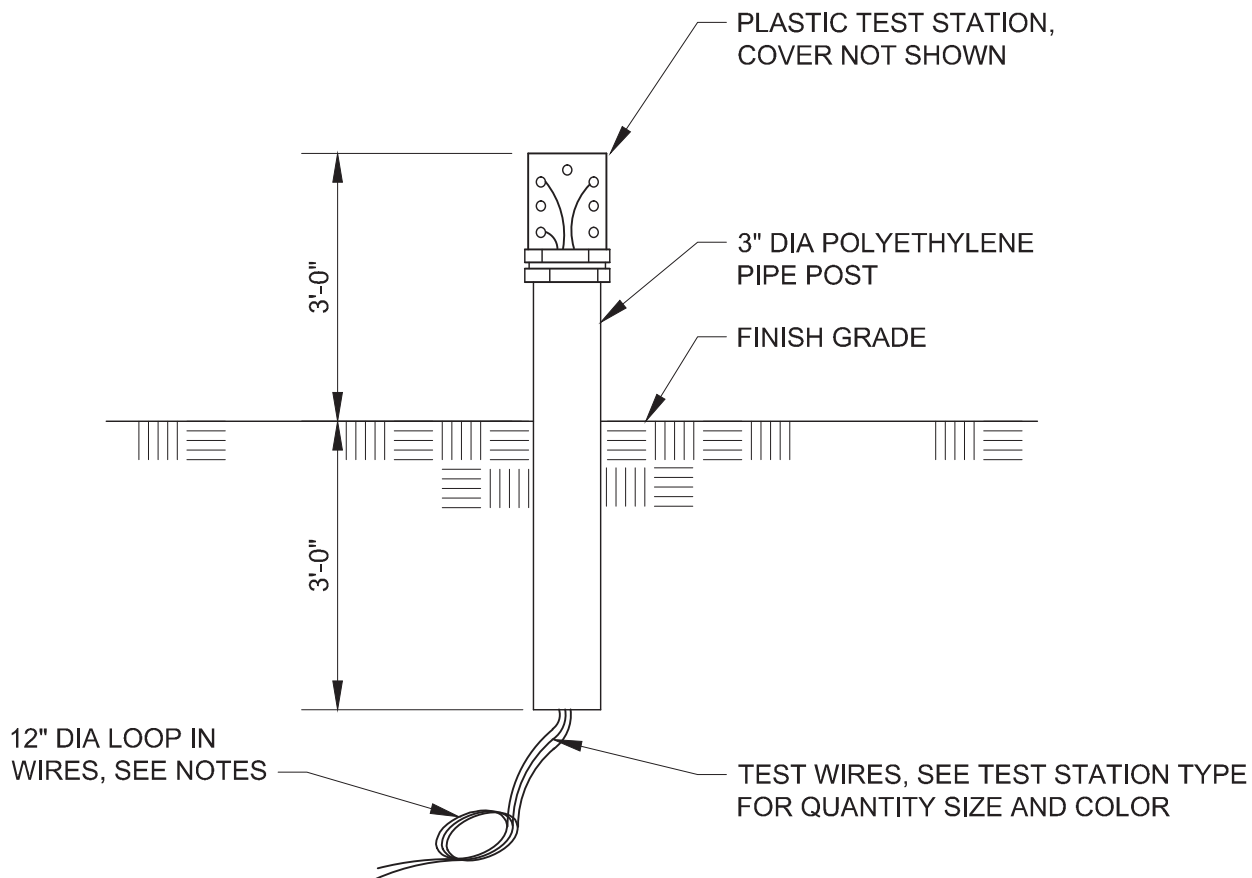

NOTES:

1. COLOR OR TEST STATION AND POST AS SPECIFIED.
2. QUANTITY OF TERMINALS AND WIRING CONNECTIONS VARIES, SEE APPLICABLE TEST STATION DETAILS FOR TYPE OF TEST STATION.
3. PROVIDE WIRE LOP AT BASE OF POST MOUNTED TEST STATION TO MINIMIZE SETTLEMENT STRESSES ON WIRE



PARK CITY MUNICIPAL CORPORATION  
**WATER**

DATE

03/2014

REV.

0

**POST STYLE TEST STATION  
 PLASTIC**

STD. PLAN

**538-B**

2'-6" X 6" THICK FORMED  
CONCRETE PAD

8" DIA CAST IRON COVER  
MARKED "TEST STATION"

MICARTA BOARD WITH  
SST TERMINALS, SEE  
STD. PLAN 538-D

12" METER BOX, PROVIDE  
EXTENSION WHERE  
SPECIFIED, EXTENSION  
NOT SHOWN

TEST WIRES, NOT ALL SHOWN

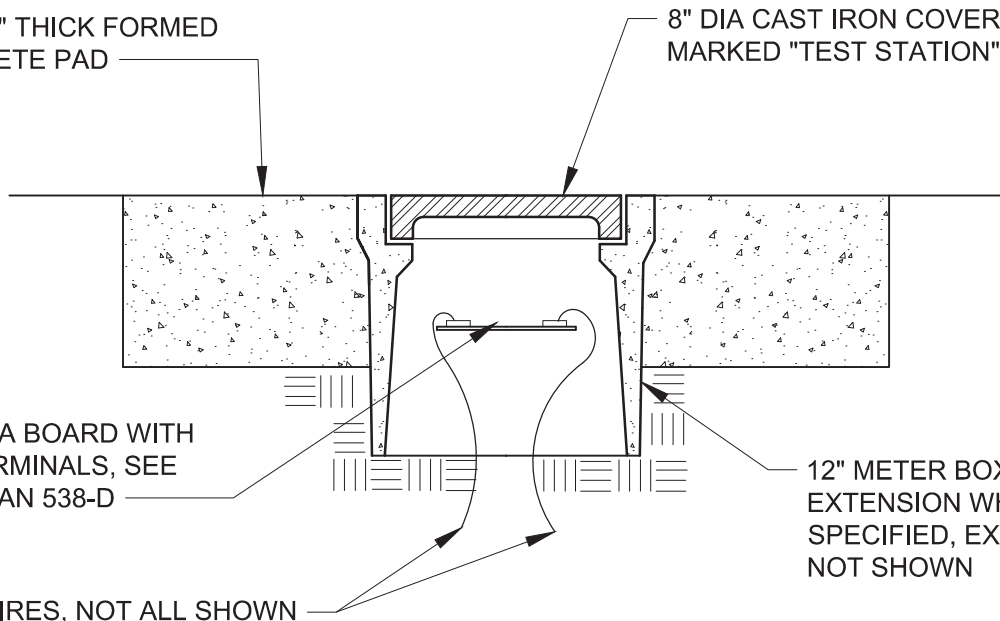

NOTES:

1. COLOR CODE WIRE INSULATION AS SHOWN IN APPLICABLE TEST STATION DETAILS, CONNECT EACH TEST WIRE TO SEPARATE TERMINAL.
2. WIRE CONFIGURATION FOR FLUSH MOUNTED TEST STATIONS SIMILAR TO POST MOUNTED TEST STATIONS.
3. PROVIDE 18 INCHES SLACK IN TEST WIRES, MINIMUM.



PARK CITY MUNICIPAL CORPORATION  
**WATER**

DATE

03/2014

REV.

0

**FLUSH STYLE  
TEST STATION BOX**

STD. PLAN

**538-C**

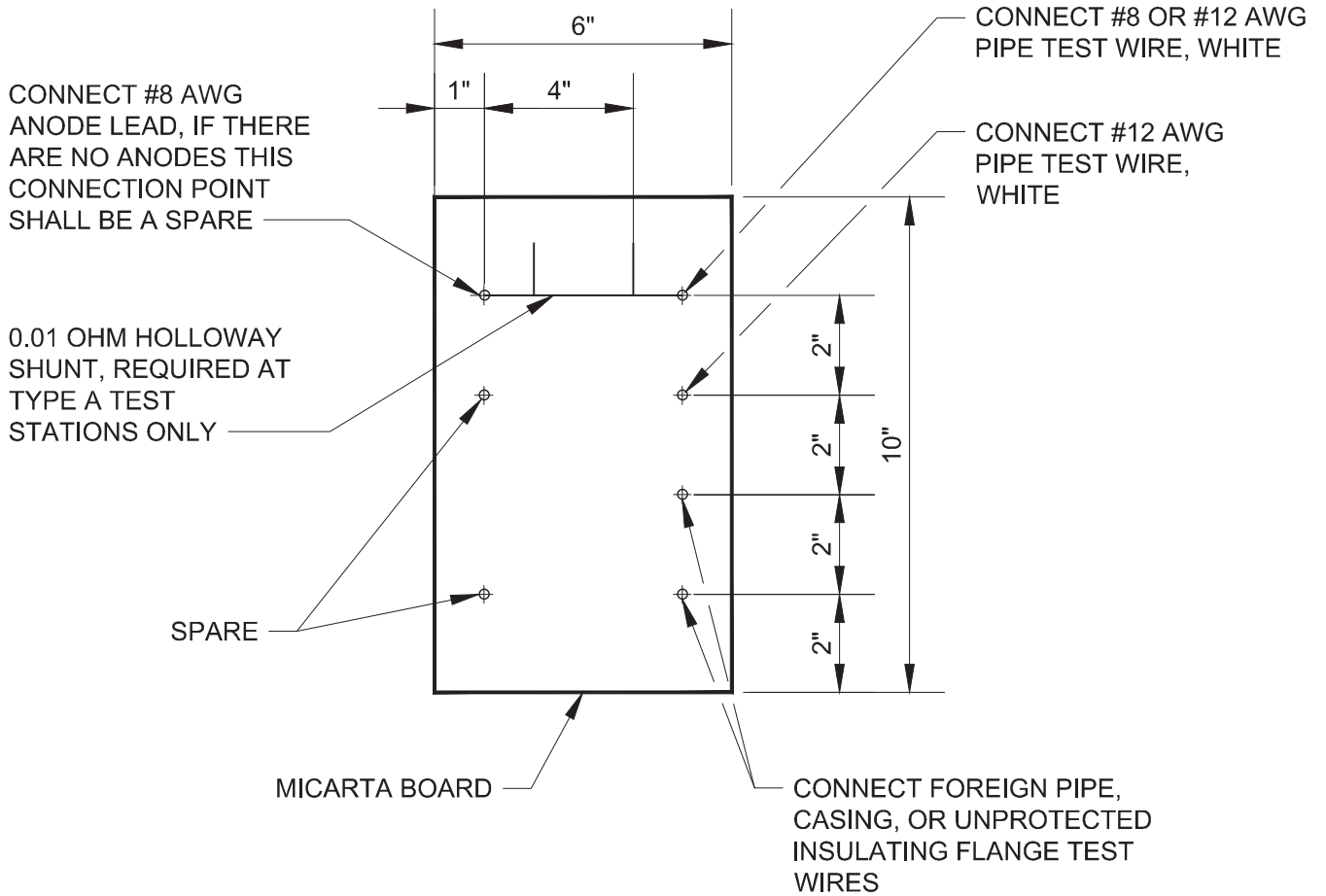

**NOTES:**

1. TERMINALS SHALL BE 1/4" STAINLESS STEEL WITH LOCKING WASHER, TWO FLAT WASHERS, AND DOUBLE NUTS.
2. ALL WIRE CONNECTIONS TO BE WITH RING TONGUE COMPRESSION TERMINALS.



PARK CITY MUNICIPAL CORPORATION  
**WATER**

DATE

02/2014

REV.

0

**FLUSH STYLE TEST STATION  
TERMINAL BOARD**

STD. PLAN

**538-D**