

15-MAR-2024 DGN File Path: \\parrish\home\parrish\Documents\Salt Lake City Projects\84565 UDOT\79481 Park City Bus Stop Program\Roadway Design\DT-01.dgn

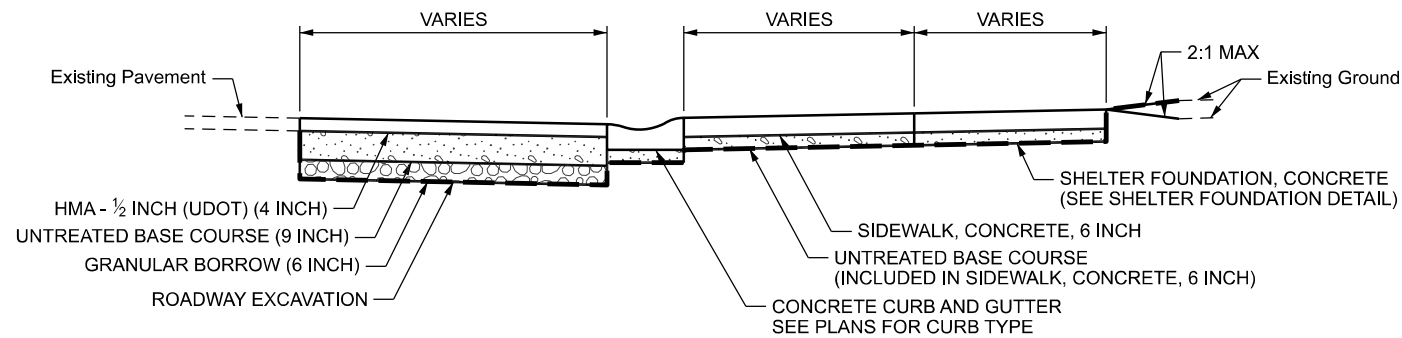

PARK CITY RESIDENTIAL COLLECTOR PAVEMENT SECTION
N.T.S.

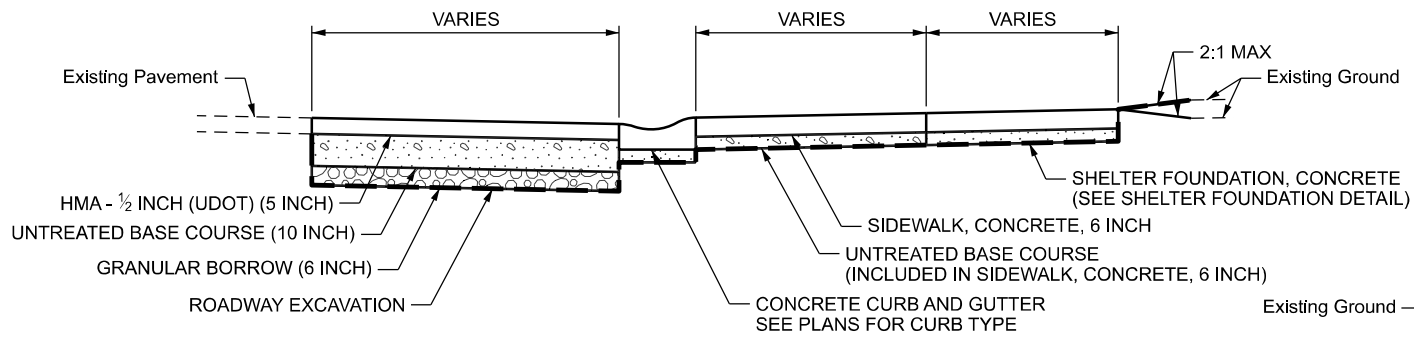

PARK CITY COMMERCIAL COLLECTOR PAVEMENT SECTION
N.T.S.

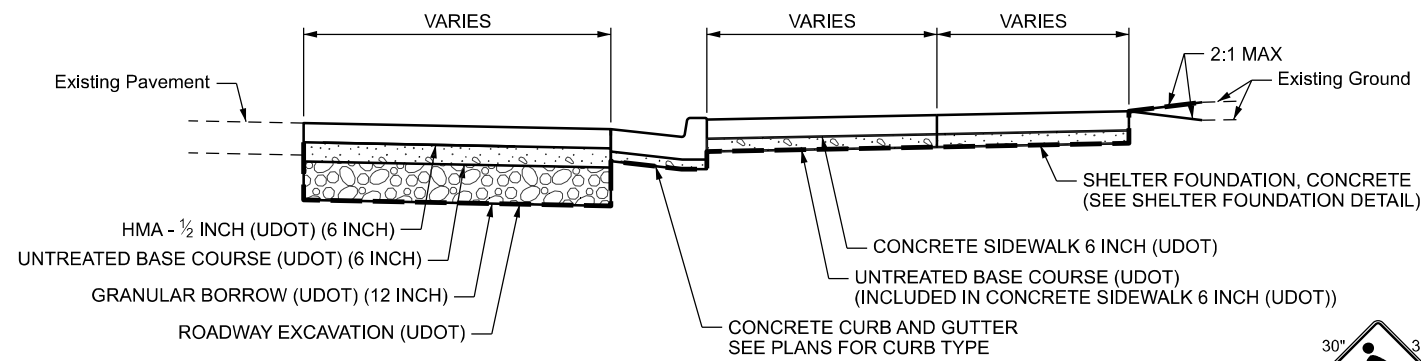

UDOT STATE ROUTE PAVEMENT SECTION
N.T.S.

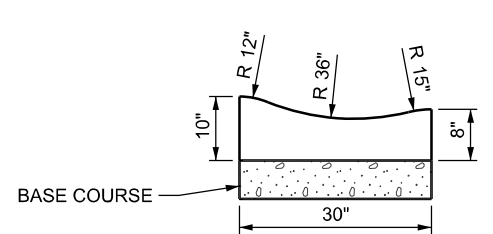

CURB AND GUTTER, TYPE G, MODIFIED
N.T.S.

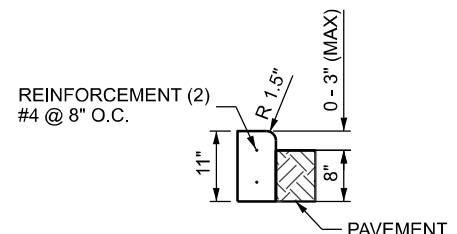

CURB, TYPE P, MODIFIED
N.T.S.

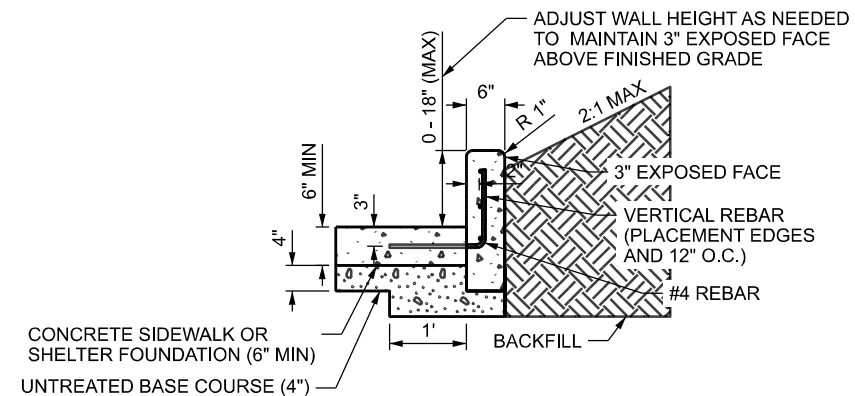

CONCRETE CURB WALL
N.T.S.

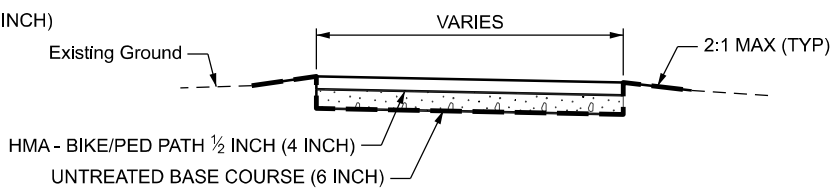

ASPHALT PATHWAY PAVEMENT SECTION
N.T.S.

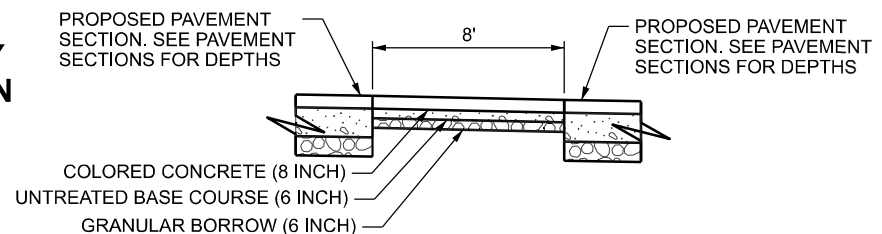

COLORED CONCRETE CROSSWALK SECTION
N.T.S.

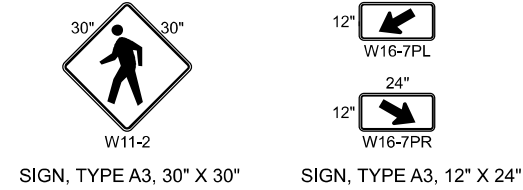

SIGN FACE DETAILS
N.T.S.

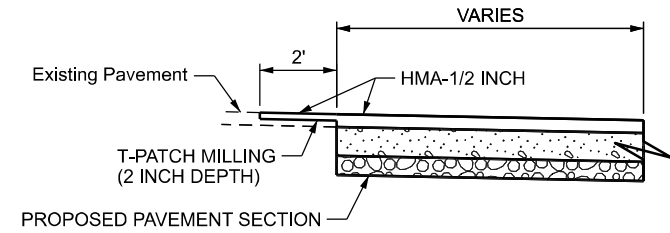

TRANSVERSE T-PATCH SECTION
N.T.S.

NOTES:
1. SEE RD SHEETS FOR PAVEMENT AND SIDEWALK DIMENSIONS

SCALE: 1" = 10'

REVISIONS		NO.		DATE		APPROVED BY		REMARKS	
PARK CITY MUNICIPAL CORPORATION PARAMETRIX APPROVED: <i>Adam Jacob</i> PROFESSIONAL ENGINEER DATE: 03/07/2024 QC CHECKED BY: _____ CDV AMP									
PROJECT		PROJECT NUMBER		GENERAL DETAILS		PARK CITY BUS STOP PROGRAM		PROJECT NUMBER CP0025	
SHEET NO.		DT-01							

- NOTES:
 1. SEE DT-01 FOR TRANSVERSE T-PATCH SECTION
 2. SEE RD-01B FOR LIMITS
 3. AWAITING PERMIT TO ENTER. DO NOT PERFORM WORK WITHOUT PARK CITY APPROVAL

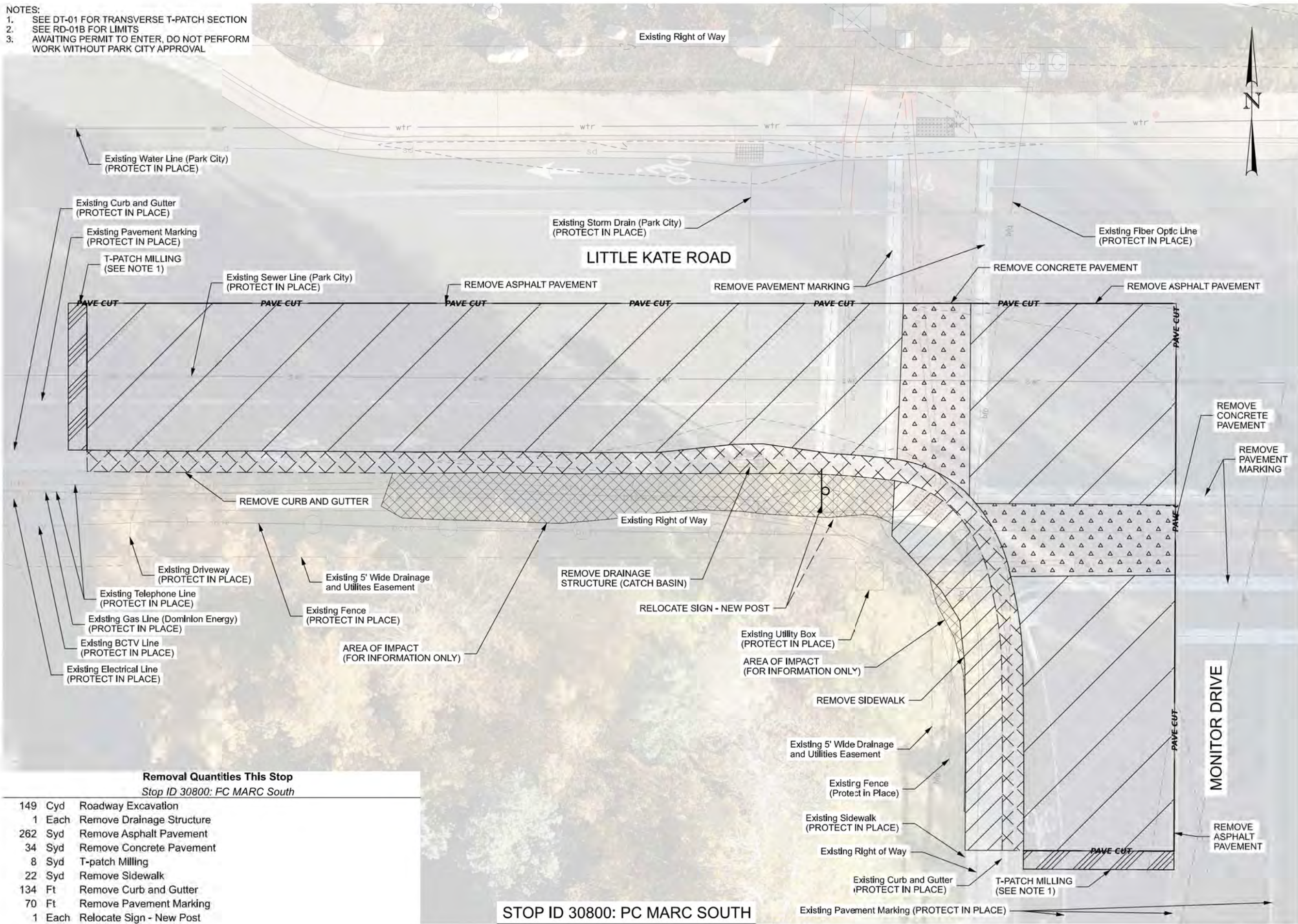

Removal Quantities This Stop
 Stop ID 30800: PC MARC South

149	Cyd	Roadway Excavation
1	Each	Remove Drainage Structure
262	Syd	Remove Asphalt Pavement
34	Syd	Remove Concrete Pavement
8	Syd	T-patch Milling
22	Syd	Remove Slidewalk
134	Ft	Remove Curb and Gutter
70	Ft	Remove Pavement Marking
1	Each	Relocate Sign - New Post

STOP ID 30800: PC MARC SOUTH

SCALE: 1" = 10'

REVISIONS

NO.	DATE	APPROVED BY	REMARKS

PARK CITY MUNICIPAL CORPORATION
 PARAMETRIX

DRAWN BY	CLK
QC CHECKED BY	AMP

03/07/2024
 DATE

APPROVED
Parametrix
 PROFESSIONAL ENGINEER

PARK CITY BUS STOP PROGRAM

PROJECT NUMBER CP0025

REMOVAL

PROJECT NUMBER

SHEET NO. **RMV-01**

- NOTES:
1. SEE DT-01, PARK CITY RESIDENTIAL COLLECTOR PAVEMENT SECTION
 2. SEE DT-01, TRANSVERSE T-PATCH DETAIL
 3. SEE RD-01B FOR GRADING DETAILS
 4. SEE DT-01 FOR COLORED CONCRETE, CROSSWALK SECTION. CONTACT CITY ENGINEER FOR COLORED CONCRETE COLOR.

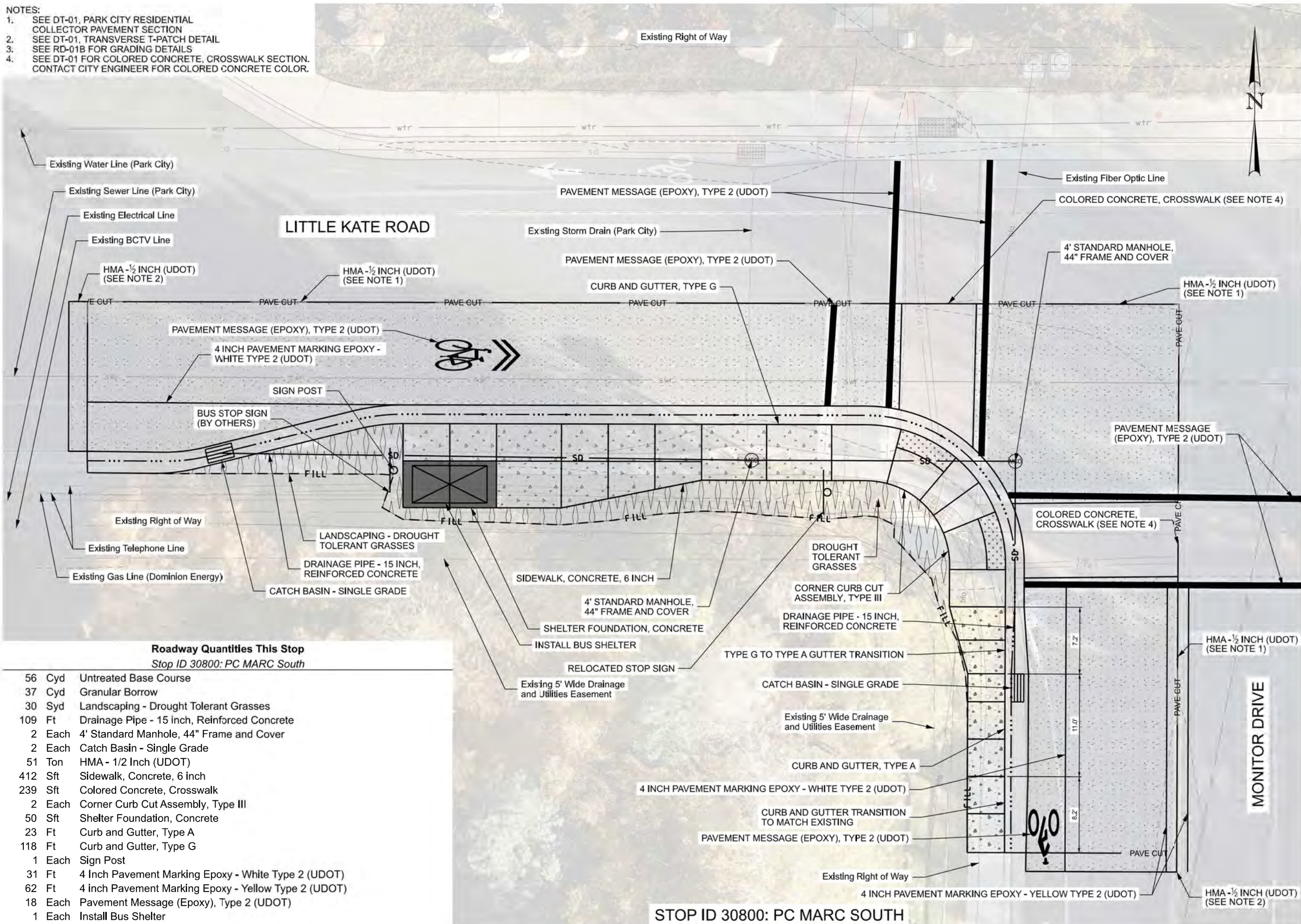

Roadway Quantities This Stop
Stop ID 30800: PC MARC South

56	Cyd	Untreated Base Course
37	Cyd	Granular Borrow
30	Syd	Landscaping - Drought Tolerant Grasses
109	Ft	Drainage Pipe - 15 inch, Reinforced Concrete
2	Each	4' Standard Manhole, 44" Frame and Cover
2	Each	Catch Basin - Single Grade
51	Ton	HMA - 1/2 Inch (UDOT)
412	Sft	Sidewalk, Concrete, 6 inch
239	Sft	Colored Concrete, Crosswalk
2	Each	Corner Curb Cut Assembly, Type III
50	Sft	Shelter Foundation, Concrete
23	Ft	Curb and Gutter, Type A
118	Ft	Curb and Gutter, Type G
1	Each	Sign Post
31	Ft	4 Inch Pavement Marking Epoxy - White Type 2 (UDOT)
62	Ft	4 inch Pavement Marking Epoxy - Yellow Type 2 (UDOT)
18	Each	Pavement Message (Epoxy), Type 2 (UDOT)
1	Each	Install Bus Shelter

STOP ID 30800: PC MARC SOUTH

SCALE: 1" = 10'

REVISIONS		APPROVED		DATE		NO.		DATE		APPROVED BY		REMARKS	
PARK CITY MUNICIPAL CORPORATION PARAMETRIX												DRAWN BY: JPN QC CHECKED BY: [Signature] DATE: 03/07/2024	
PARK CITY BUS STOP PROGRAM PROJECT NUMBER CP0025 ROADWAY												APPROVED: [Signature] PROFESSIONAL ENGINEER	
PROJECT		PROJECT NUMBER		SHEET NO.		RD-01A							

15-MAR-2024 1:54 PM C:\Users\paul\OneDrive\Documents\Salt Lake City Projects\24565 U01 (PWS) Park City Bus Stop Program\Roadway Design\20110 (RMV-03) 20110.dgn

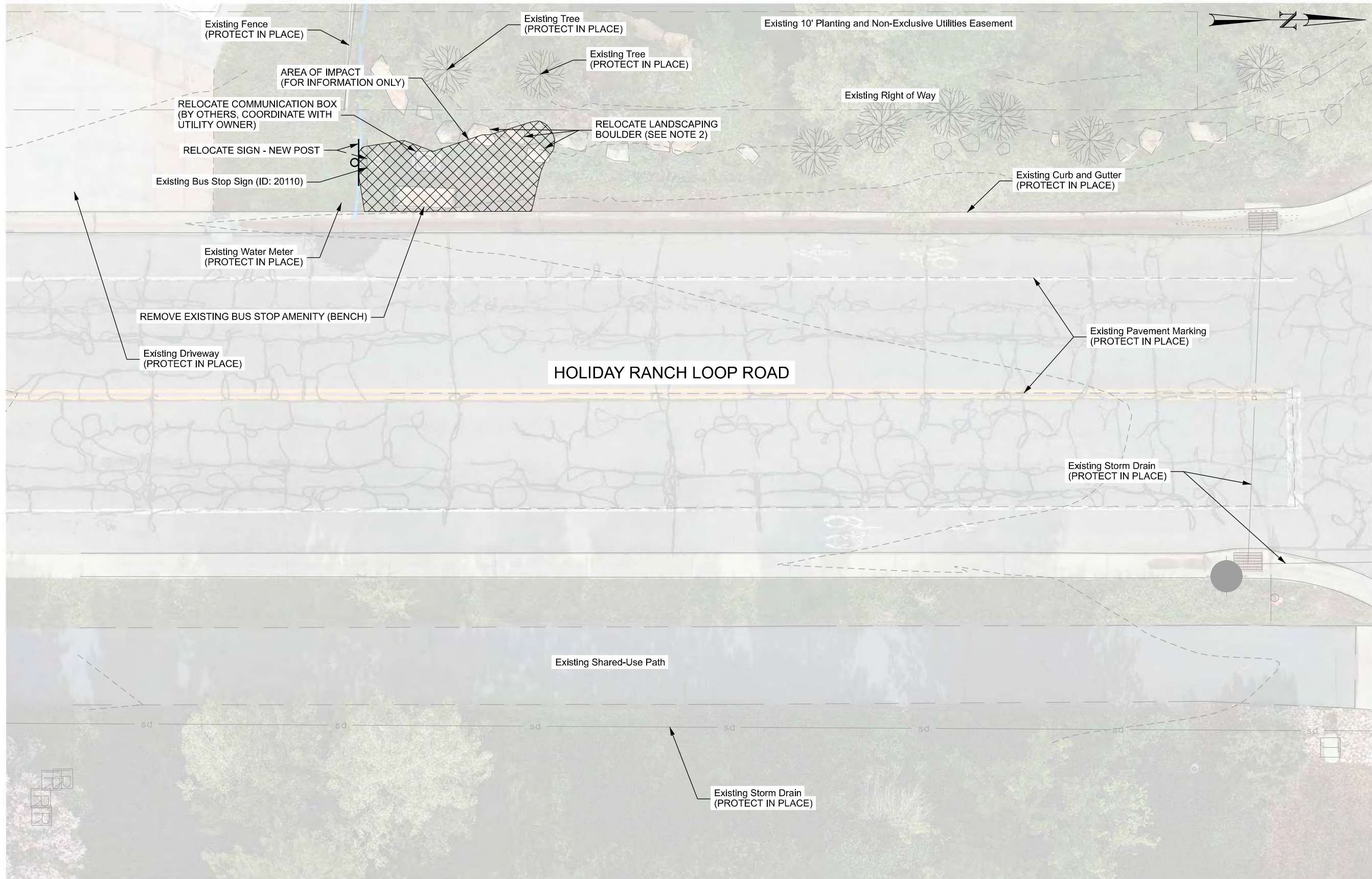

Removal Quantities This Stop
 Stop ID 20110: Holiday Ranch Loop Rd

- 4 Cyd Roadway Excavation
- 1 Each Remove Existing Bus Stop Amenity
- 3 Each Relocate Landscaping Boulder
- 1 Each Relocate Sign - New Post

STOP ID 20110: HOLIDAY RANCH LOOP RD AND QUAKING ASPEN CT

NOTES:
 1. SEE RD-03 FOR LIMITS
 2. CONTRACTOR TO COORDINATE WITH LAND OWNER FOR FINAL BOULDER PLACEMENT

SCALE: 1" = 10'

REVISIONS	
NO.	DATE

PARK CITY MUNICIPAL CORPORATION	
PARAMETRIX	
DRAWN BY JPN	APPROVED <i>Blair</i> PROFESSIONAL ENGINEER
QC CHECKED BY AMP	DATE 03/07/2024
PARK CITY BUS STOP PROGRAM PROJECT NUMBER CP0025 REMOVAL	
PROJECT	REMARKS

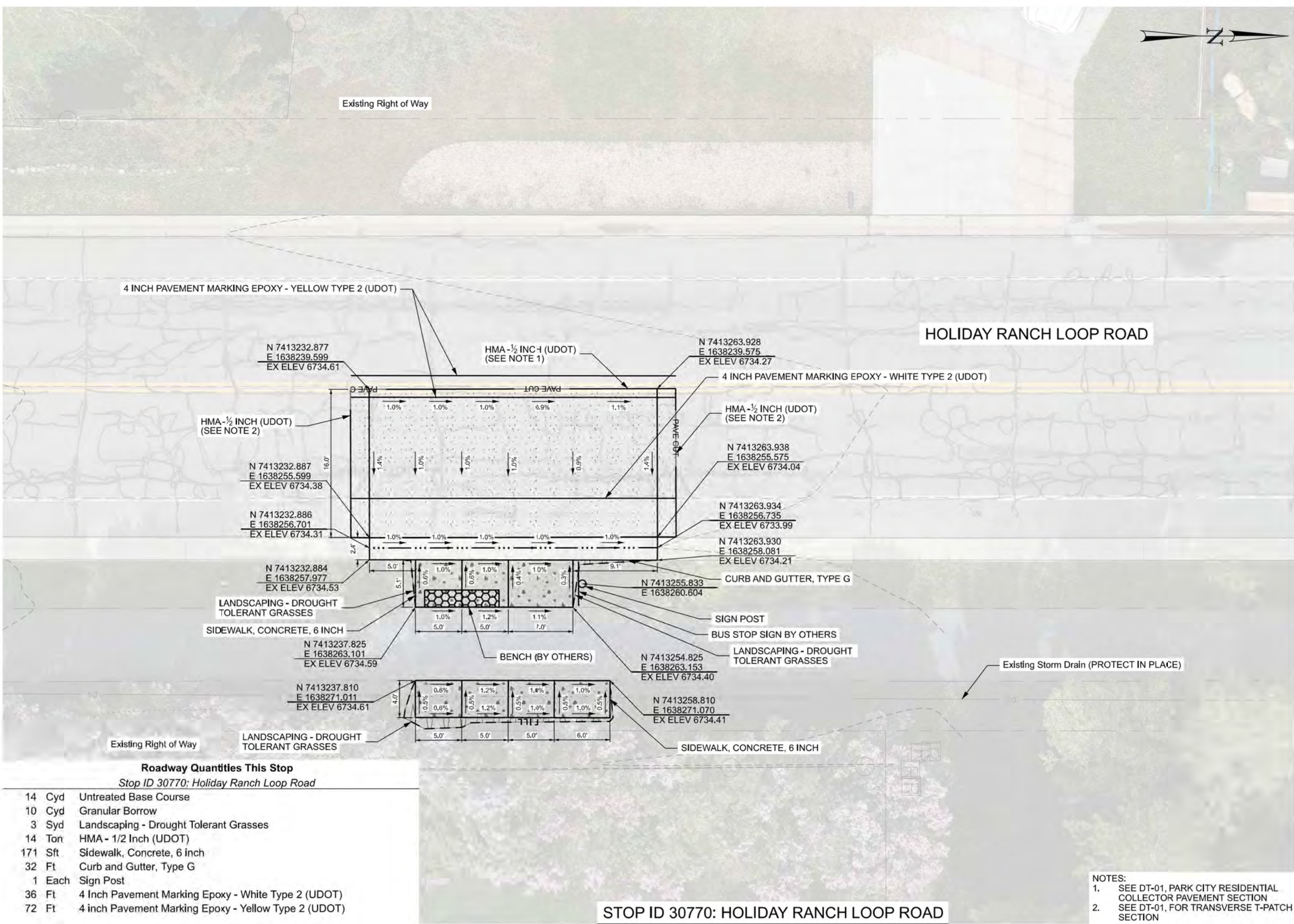

Existing Right of Way

HOLIDAY RANCH LOOP ROAD

4 INCH PAVEMENT MARKING EPOXY - YELLOW TYPE 2 (UDOT)

N 7413232.877
E 1638239.599
EX ELEV 6734.61

HMA - 1/2 INCH (UDOT)
(SEE NOTE 1)

N 7413263.928
E 1638239.575
EX ELEV 6734.27

HMA - 1/2 INCH (UDOT)
(SEE NOTE 2)

N 7413232.887
E 1638255.599
EX ELEV 6734.38

HMA - 1/2 INCH (UDOT)
(SEE NOTE 2)

N 7413263.938
E 1638255.575
EX ELEV 6734.04

N 7413232.886
E 1638256.701
EX ELEV 6734.31

N 7413263.934
E 1638256.735
EX ELEV 6733.99

N 7413263.930
E 1638258.081
EX ELEV 6734.21

N 7413232.884
E 1638257.977
EX ELEV 6734.53

N 7413255.833
E 1638260.604

LANDSCAPING - DROUGHT
TOLERANT GRASSES

CURB AND GUTTER, TYPE G

SIGN POST
BUS STOP SIGN BY OTHERS

SIDEWALK, CONCRETE, 6 INCH

BENCH (BY OTHERS)

LANDSCAPING - DROUGHT
TOLERANT GRASSES

N 7413237.825
E 1638263.101
EX ELEV 6734.59

N 7413254.825
E 1638263.153
EX ELEV 6734.40

Existing Storm Drain (PROTECT IN PLACE)

N 7413237.810
E 1638271.011
EX ELEV 6734.61

N 7413258.810
E 1638271.070
EX ELEV 6734.41

Existing Right of Way

LANDSCAPING - DROUGHT
TOLERANT GRASSES

SIDEWALK, CONCRETE, 6 INCH

Roadway Quantities This Stop

Stop ID 30770: Holiday Ranch Loop Road

14	Cyd	Untreated Base Course
10	Cyd	Granular Borrow
3	Syd	Landscaping - Drought Tolerant Grasses
14	Ton	HMA - 1/2 Inch (UDOT)
171	Sft	Sidewalk, Concrete, 6 inch
32	Ft	Curb and Gutter, Type G
1	Each	Sign Post
36	Ft	4 Inch Pavement Marking Epoxy - White Type 2 (UDOT)
72	Ft	4 inch Pavement Marking Epoxy - Yellow Type 2 (UDOT)

NOTES:
 1. SEE DT-01, PARK CITY RESIDENTIAL COLLECTOR PAVEMENT SECTION
 2. SEE DT-01, FOR TRANSVERSE T-PATCH SECTION

STOP ID 30770: HOLIDAY RANCH LOOP ROAD

SCALE: 1" = 10'

PARK CITY MUNICIPAL CORPORATION		PARAMETRIX	
PROJECT	PARK CITY BUS STOP PROGRAM	APPROVED	PROFESSIONAL ENGINEER
PROJECT NUMBER	CP0025	DRAWN BY	JPN
SHEET NO.	RD-04	QC CHECKED BY	
REVISIONS		DATE	03/07/2024
		NO.	
		DATE	
		APPROVED BY	
		AMP	
		REMARKS	

D:\GIS\Projects\30740\Drawings\30740-RD-06-30740.dwg

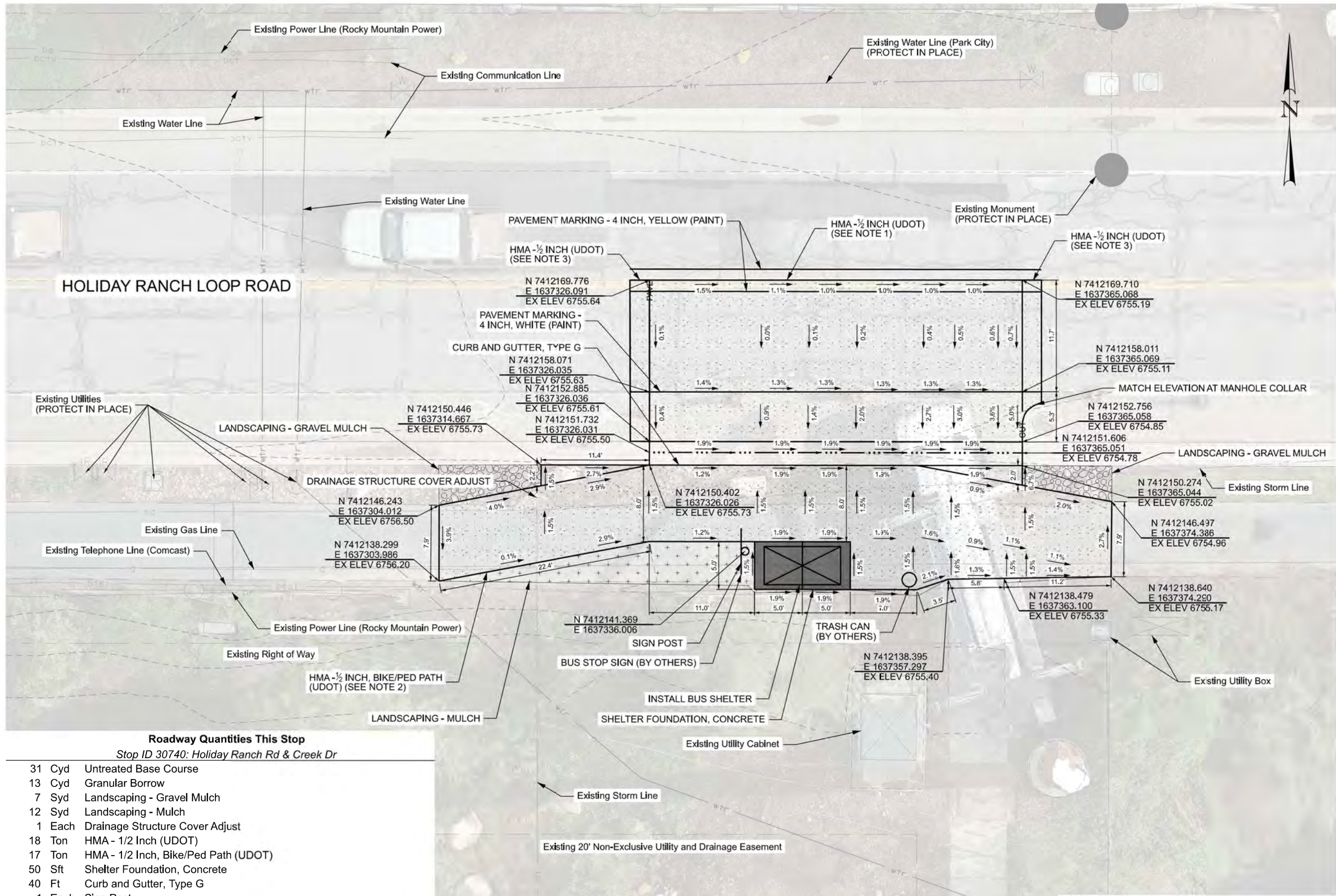

NO.	DATE	APPROVED BY	REMARKS

HOLIDAY RANCH LOOP ROAD

Roadway Quantities This Stop
Stop ID 30740: Holiday Ranch Rd & Creek Dr

31	Cyd	Untreated Base Course
13	Cyd	Granular Borrow
7	Syd	Landscaping - Gravel Mulch
12	Syd	Landscaping - Mulch
1	Each	Drainage Structure Cover Adjust
18	Ton	HMA - 1/2 Inch (UDOT)
17	Ton	HMA - 1/2 Inch, Bike/Ped Path (UDOT)
50	Sft	Shelter Foundation, Concrete
40	Ft	Curb and Gutter, Type G
1	Each	Sign Post
44	Ft	4 Inch Pavement Marking Epoxy - White Type 2 (UDOT)
88	Ft	4 inch Pavement Marking Epoxy - Yellow Type 2 (UDOT)
1	Each	Install Bus Shelter

STOP ID 30740: HOLIDAY RANCH LOOP ROAD & CREEK DRIVE

- NOTES:**
- SEE DT-01, PARK CITY RESIDENTIAL COLLECTOR PAVEMENT SECTION
 - SEE DT-01, ASPHALT PATHWAY PAVEMENT SECTION
 - SEE DT-01 FOR TRANSVERSE T-PATCH SECTION

SCALE: 1" = 10'

PARK CITY MUNICIPAL CORPORATION	APPROVED	DATE	03/07/2024
	PROFESSIONAL ENGINEER	DATE	
PARAMETRIX	DRAWN BY	JPN	
	QC CHECKED BY		
PARK CITY BUS STOP PROGRAM	PROJECT NUMBER	CP0025	
	ROADWAY		
PROJECT			
PROJECT NUMBER			
SHEET NO.	RD-06		

I:\Projects\2024\24-001\Drawings\24-001-08B-RMV-08A-0100.dwg
 15-MAR-2024 10:51:32 AM
 User: jason.lundberg
 Plot: 24-001-08B-RMV-08A-0100.dwg
 Title: 24-001-08B-RMV-08A-0100.dwg
 Project: 24-001-08B-RMV-08A-0100.dwg
 City: Park City
 State: Utah
 Country: USA
 Scale: 1" = 10'
 Date: 03/07/2024
 Time: 10:51:32 AM
 Author: jason.lundberg
 Checker: jason.lundberg
 Approver: jason.lundberg
 Description: 24-001-08B-RMV-08A-0100.dwg

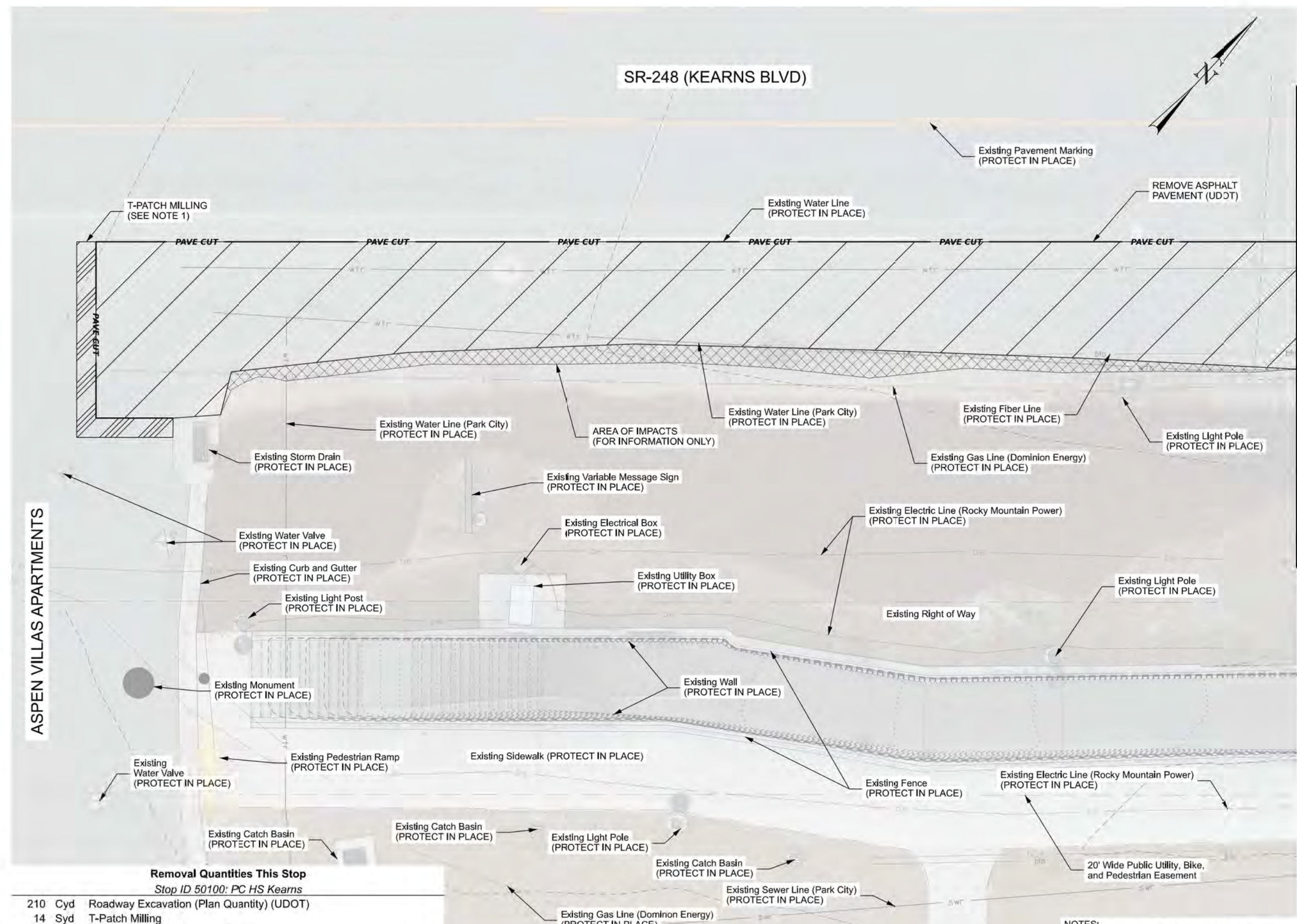

Removal Quantities This Stop
 Stop ID 50100: PC HS Kearns

210	Cyd	Roadway Excavation (Plan Quantity) (UDOT)
14	Syd	T-Patch Milling
352	Syd	Remove Asphalt Pavement (UDOT)
1	Each	Relocate Sign Less Than 20 Square Feet (UDOT)

STOP ID 50100: PC HIGH SCHOOL KEARNS

- NOTES:**
- SEE DT-01 FOR TRANSVERSE T-PATCH SECTION
 - SEE RD-08A FOR LIMITS

SCALE: 1" = 10'

REVISIONS		NO.		DATE		APPROVED BY		REMARKS	
PARK CITY MUNICIPAL CORPORATION		PARAMETRIX		APPROVED		DRAWN BY		CDV	
PARK CITY BUS STOP PROGRAM		PROJECT NUMBER CP0025		PROFESSIONAL ENGINEER		QC CHECKED BY		AMP	
REMOVAL		03/07/2024		DATE					
PROJECT		PROJECT NUMBER							
SHEET NO. RMV-08A									

I:\Projects\2024\50080\Drawings\Roadway\Drawings\50080-RD-09-50080.dwg
 03/07/2024 10:07:40 AM
 User: parametrix
 Plot: 50080-RD-09-50080.dwg
 Scale: 1" = 10'
 Date: 03/07/2024
 Time: 10:07:40 AM
 Project: 50080
 Drawing: 50080-RD-09-50080.dwg
 Title: STOP ID 50080: IRON HORSE DR & SHORT LINE RD

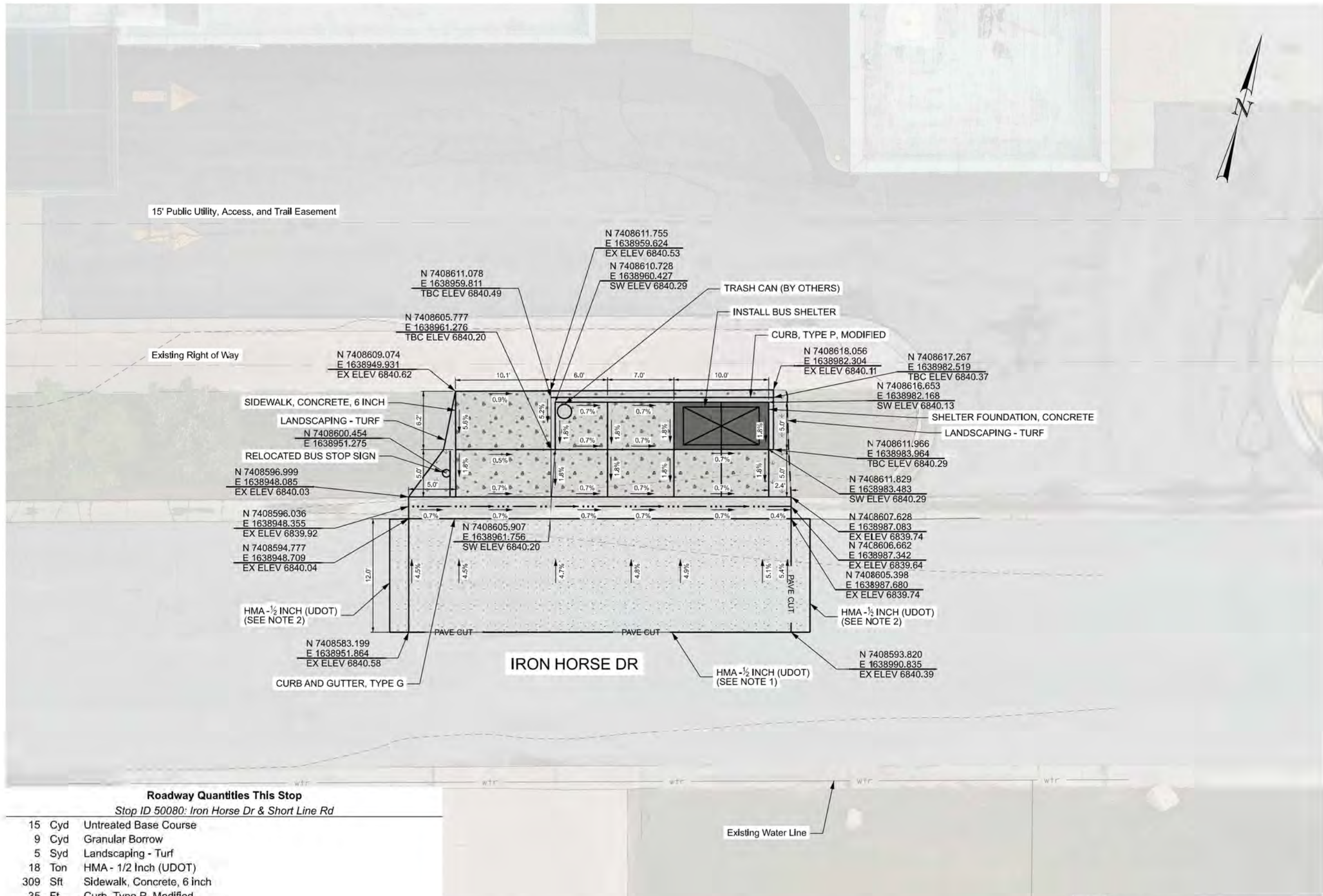

15' Public Utility, Access, and Trail Easement

Existing Right of Way

Roadway Quantities This Stop
 Stop ID 50080: Iron Horse Dr & Short Line Rd

- 15 Cyd Untreated Base Course
- 9 Cyd Granular Borrow
- 5 Syd Landscaping - Turf
- 18 Ton HMA - 1/2 Inch (UDOT)
- 309 Sft Sidewalk, Concrete, 6 inch
- 35 Ft Curb, Type P, Modified
- 50 Sft Shelter Foundation, Concrete
- 41 Ft Curb and Gutter, Type G

STOP ID 50080: IRON HORSE DR & SHORT LINE RD

NOTES:

1. SEE DT-01, PARK CITY RESIDENTIAL COLLECTOR PAVEMENT SECTION
2. SEE DT-01, FOR TRANSVERSE T-PATCH SECTION

SCALE: 1" = 10'

REVISIONS

NO.	DATE	APPROVED BY	REMARKS

PARK CITY MUNICIPAL CORPORATION
 PARAMETRIX

APPROVED	DATE	QC CHECKED BY	AMP
<i>Adam Beck</i>	03/07/2024		
PROFESSIONAL ENGINEER			

PARK CITY BUS STOP PROGRAM

PROJECT NUMBER CP0025

ROADWAY

PROJECT NUMBER	RD-09
SHEET NO.	

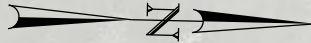
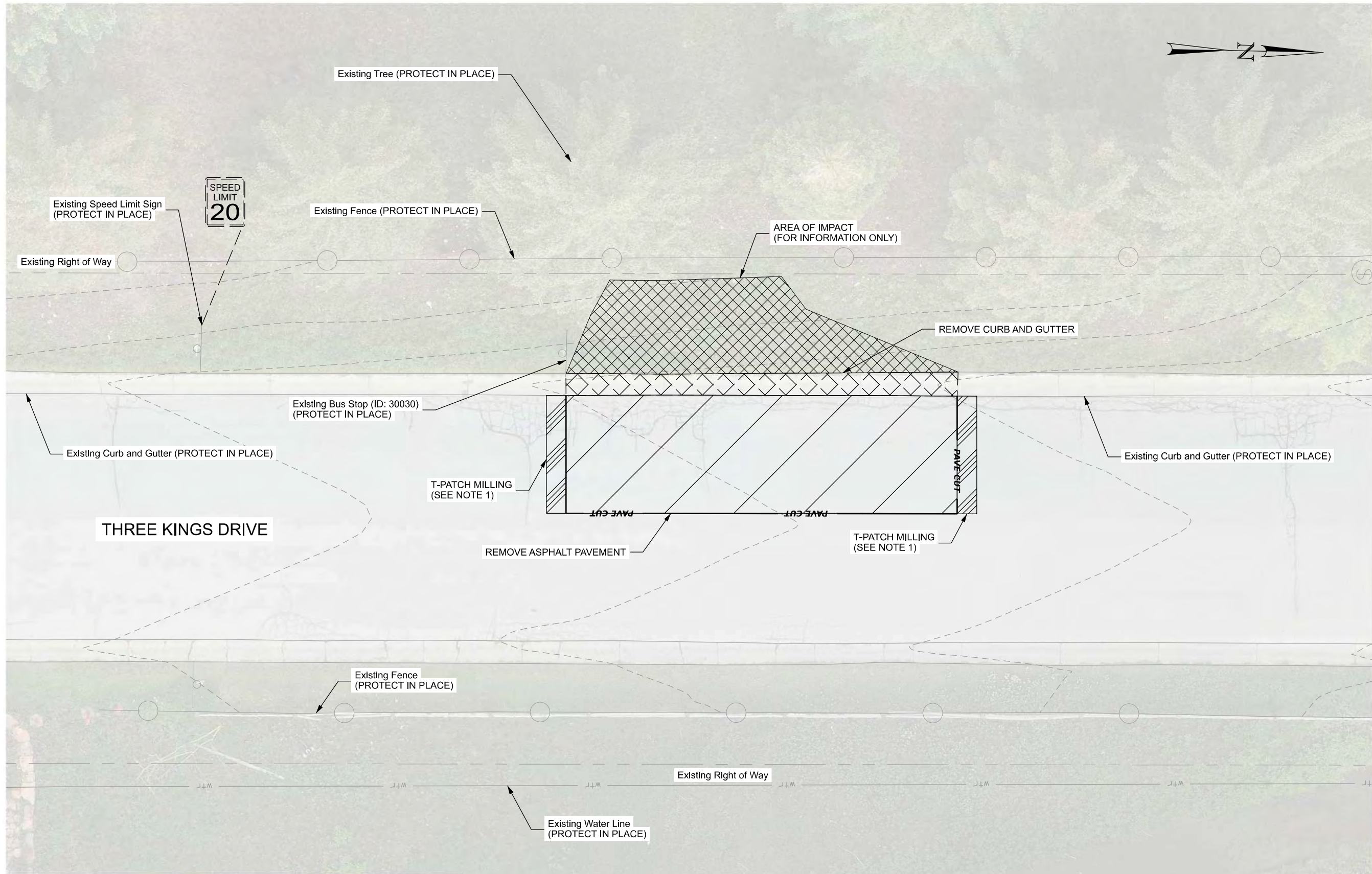

THREE KINGS DRIVE

Removal Quantities This Stop

Stop ID 30030: Three Kings Drive and Thaynes Canyon Drive

32	Cyd	Roadway Excavation
54	Syd	Remove Asphalt Pavement
6	Syd	T-Patch Milling
40	Ft	Remove Curb and Gutter

STOP ID 30030: THREE KINGS DRIVE AND THAYNES CANYON DRIVE

- NOTES:
1. SEE DT-01, FOR TRANSVERSE T-PATCH SECTION
 2. SEE RD-11 FOR LIMITS

SCALE: 1" = 10'

REVISIONS											
NO.	DATE	APPROVED BY	AMP	CHECKED BY	DATE	APPROVED	DATE	NO.	DATE	APPROVED BY	REMARKS

PARK CITY MUNICIPAL CORPORATION		PARAMETRIX	
DRAWN BY JPN	QC CHECKED BY AMP	APPROVED <i>[Signature]</i> PROFESSIONAL ENGINEER	
DATE 03/07/2024		DATE 03/07/2024	
PROJECT PARK CITY BUS STOP PROGRAM	PROJECT NUMBER CP0025	REMOVAL	
SHEET NO. RMV-11			

I:\15-144R-2024-1\15-144R-2024-1\Drawings\Roadway\Drawings\30030 - 30040 RD-11-30030.dwg
 03/07/2024 10:00:00 AM
 15-144R-2024-1

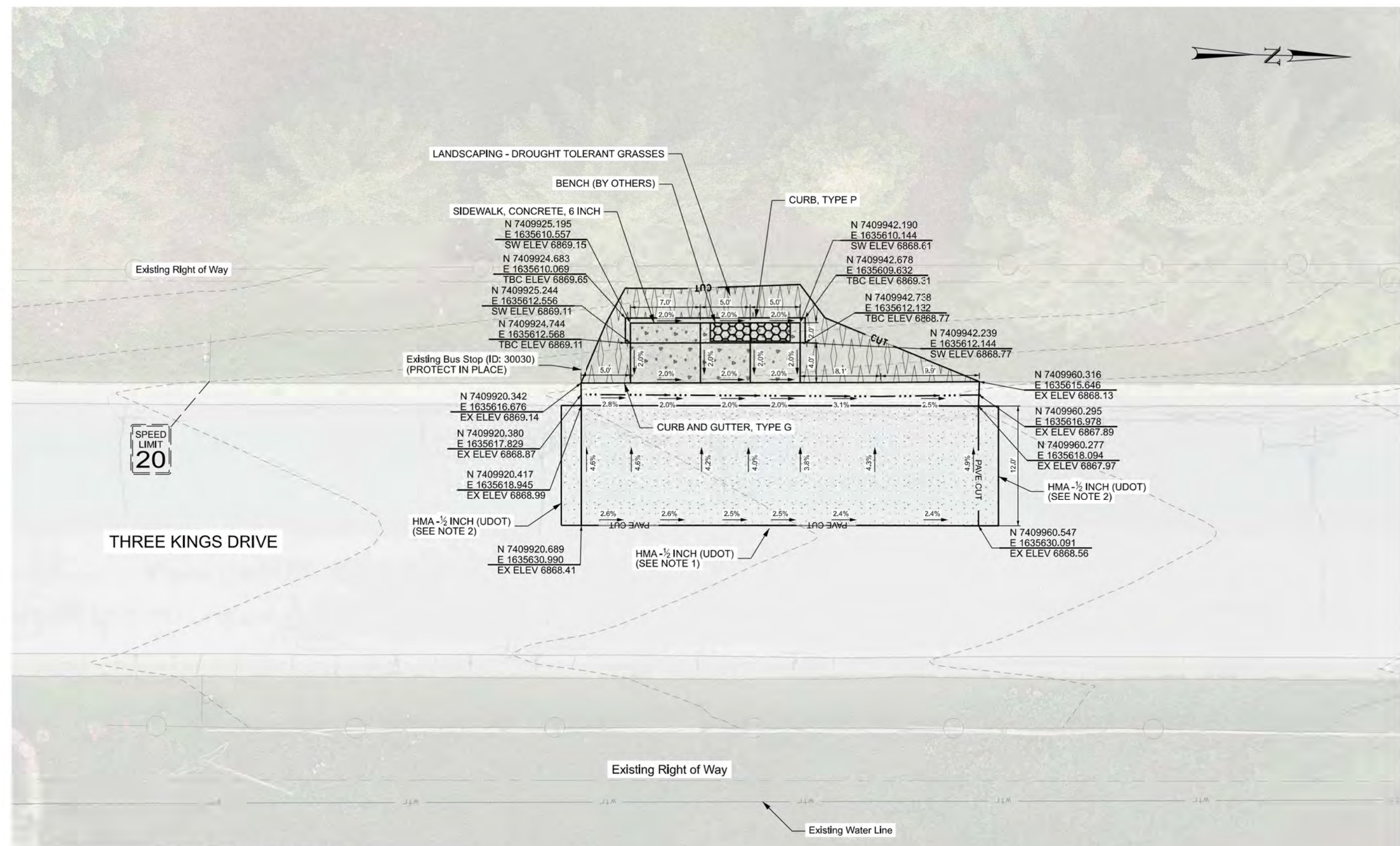

Roadway Quantities This Stop
 Stop ID 30030: Three Kings Drive and Thayne Canyon Drive

14	Cyd	Untreated Base Course
9	Cyd	Granular Borrow
17	Syd	Landscaping - Drought Tolerant Grasses
14	Ton	HMA - 1/2 Inch (UDOT)
102	Sft	Sidewalk, Concrete, 6 Inch
23	Ft	Curb, Type P
40	Ft	Curb and Gutter, Type G

STOP ID 30030: THREE KINGS DRIVE AND THAYNES CANYON DRIVE

- NOTES:**
- SEE DT-01, RESIDENTIAL COLLECTOR PAVEMENT SECTION
 - SEE DT-01 FOR TRANSVERSE T-PATCH SECTION

SCALE: 1" = 10'

REVISIONS		NO.		DATE		APPROVED BY		REMARKS	
PARK CITY MUNICIPAL CORPORATION		PARAMETRIX		DRAWN BY		JPN		CHECKED BY	
PARK CITY BUS STOP PROGRAM		PROJECT NUMBER CP0025		APPROVED		03/07/2024		DATE	
PROJECT		ROADWAY		PROFESSIONAL ENGINEER					
PROJECT NUMBER									
SHEET NO.		RD-11							

THIS PAGE INTENTIONALLY LEFT BLANK

SCALE: 1" = 10'

SHEET NO. RD-12

PROJECT		PARK CITY BUS STOP PROGRAM		PARK CITY MUNICIPAL CORPORATION		REVISIONS	
PROJECT NUMBER		PROJECT NUMBER CP0025		PARAMETRIX			
		ROADWAY		APPROVED			
				DRAWN BY			
				JPN			
				QC			
				CHECKED BY			
				03/07/2024			
				DATE			
				PROFESSIONAL ENGINEER			
				AMP			
				NO.		DATE	
				APPROVED BY		REMARKS	

15-MAR-2024 DGN File: p:\p\m\l\h\m\c\g\p\WestCoast\Documents\Salt Lake City Projects\24565 UDOT\PM\01 Park City Bus Stop Program\Roadway Design\30070 & 30098 & 30099.RVT-13.30070.dgn

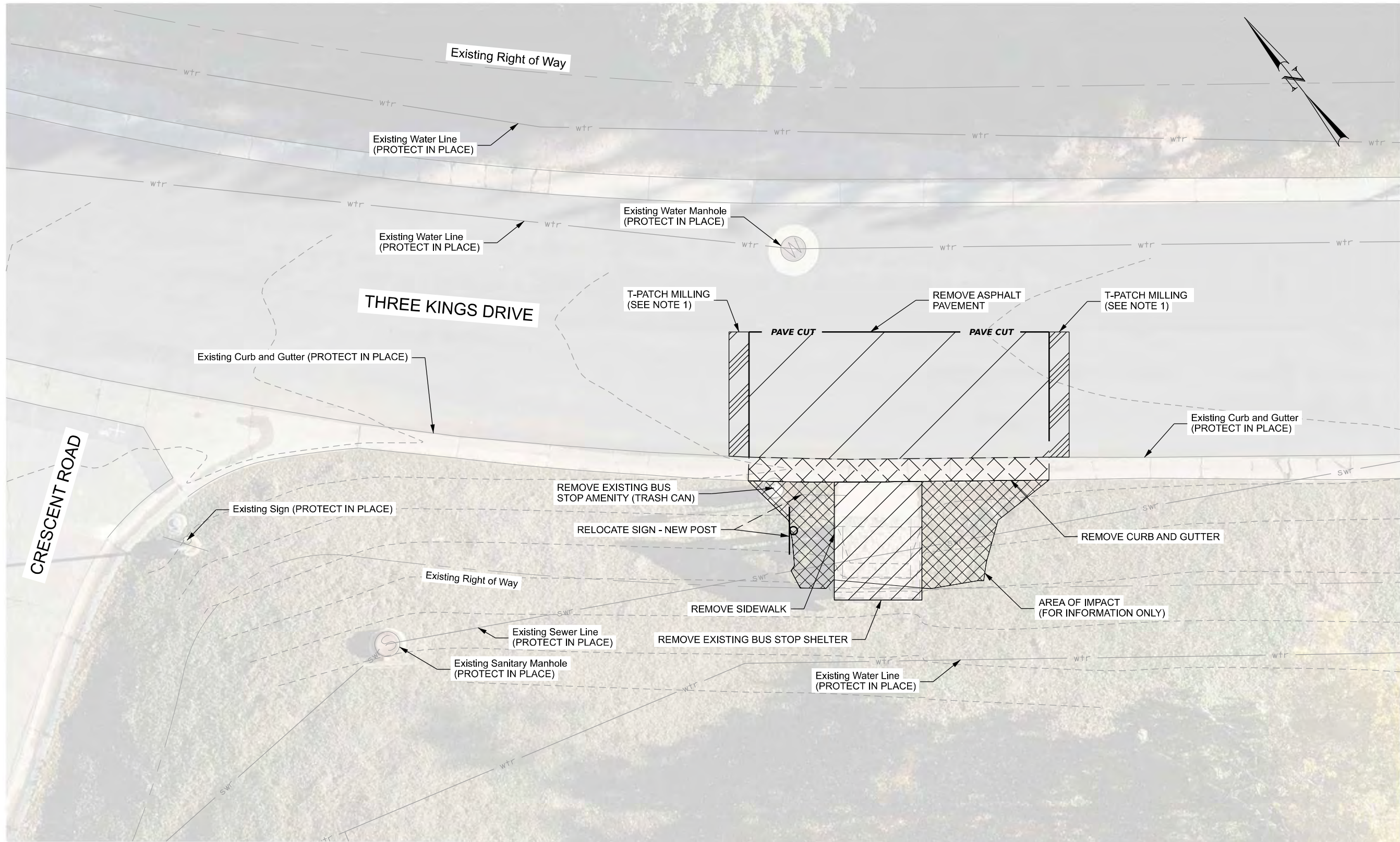

Removal Quantities This Stop

Stop ID 30070: Three Kings Drive and Crescent Road

- | | | |
|----|------|----------------------------------|
| 28 | Cyd | Roadway Excavation |
| 42 | Syd | Remove Asphalt Pavement |
| 6 | Syd | T-Patch Milling |
| 12 | Syd | Remove Sidewalk |
| 30 | Ft | Remove Curb and Gutter |
| 1 | Each | Remove Existing Bus Stop Amenity |
| 1 | Each | Remove Existing Bus Stop Shelter |
| 1 | Each | Relocate Sign - New Post |

STOP ID 30070: THREE KINGS DRIVE AND CRESCENT ROAD

- NOTES:
- SEE DT-01, FOR TRANSVERSE T-PATCH SECTION
 - SEE RD-13 FOR LIMITS

SCALE: 1" = 10'

REVISIONS

NO.	DATE	APPROVED BY	REMARKS

PARK CITY MUNICIPAL CORPORATION

PARAMETRIX

APPROVED	DATE	QC CHECKED BY	DATE	DRAWN BY	DATE
<i>W. Woodcock</i>	03/07/2024	JPN	03/07/2024	JPN	AMP
PROFESSIONAL ENGINEER					

PARK CITY BUS STOP PROGRAM

PROJECT NUMBER CP0025

REMOVAL

PROJECT

PROJECT NUMBER

SHEET NO. **RMV-13**

D:\GIS\Projects\245655 UDOT\PM\01 Park City Bus Stop Program\Roadway Design\245655\RMV-21_240224.dgn

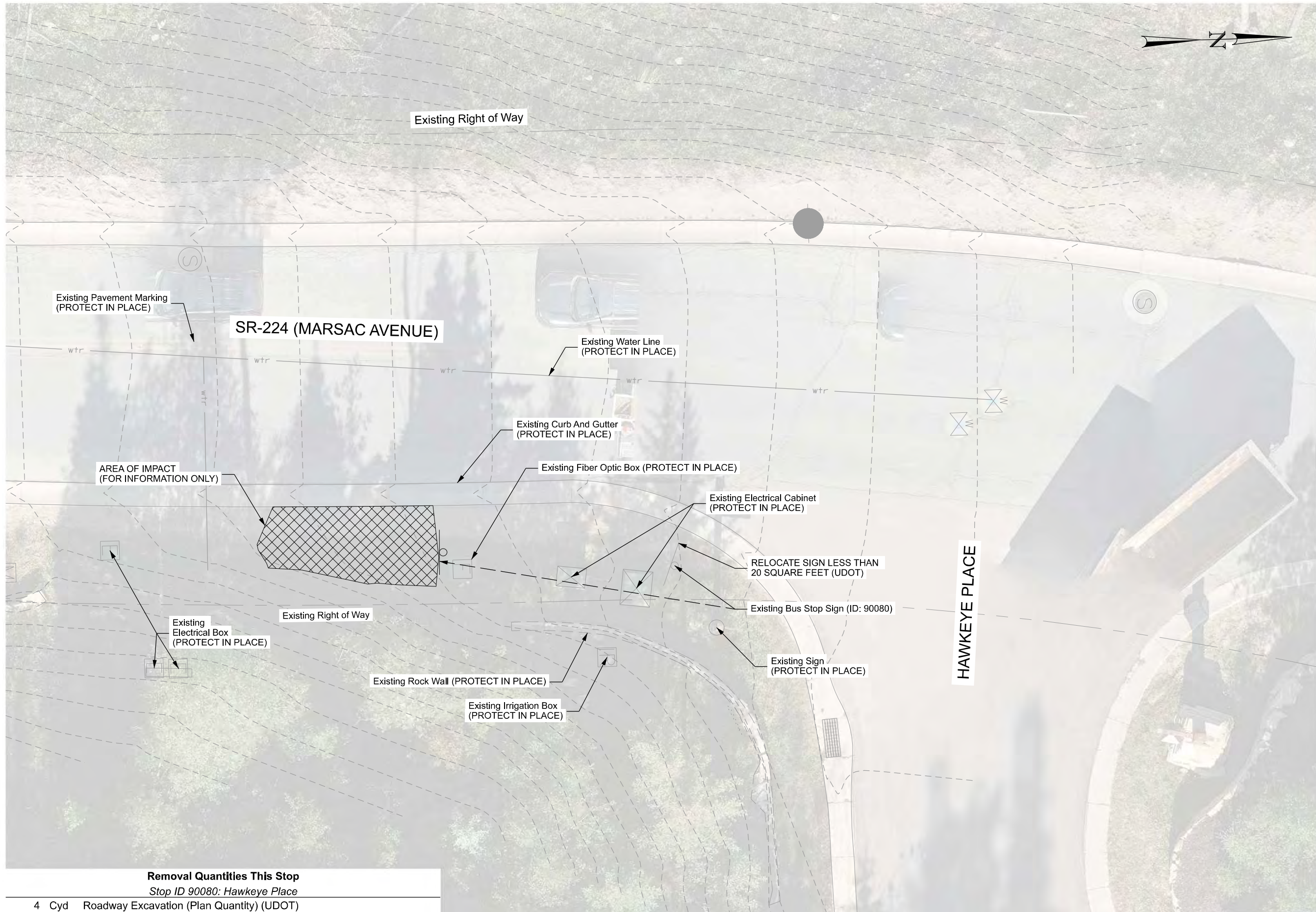

Removal Quantities This Stop
 Stop ID 90080: Hawkeye Place

- 4 Cyd Roadway Excavation (Plan Quantity) (UDOT)
- 1 Each Relocate Sign Less Than 20 Square Feet (UDOT)

STOP ID 90080: HAWKEYE PLACE ON MARSAC AVE TO MAIN ST

NOTES:
 1. SEE RD-21 FOR LIMITS
 SCALE: 1" = 10'

PARK CITY MUNICIPAL CORPORATION		PARAMETRIX	
PROJECT	PARK CITY BUS STOP PROGRAM	APPROVED	<i>Alumbeck</i> PROFESSIONAL ENGINEER
PROJECT NUMBER	PROJECT NUMBER CP0025	DATE	03/07/2024
	REMOVAL	QC CHECKED BY	JPN
		DATE	
		NO.	
		DATE	
		APPROVED BY	
		REMARKS	

SURVEY CONTROL

ESTABLISHED FOR BUS STOP MAPPING OF PROJECT LOCATIONS IN THE LOWER PARK CITY VALLEY
SITUATE IN THE SOUTH HALF (S 1/2) OF SECTION 21, AND THE NORTH HALF (N 1/2) OF SECTION 28,
TOWNSHIP 2 SOUTH, RANGE 4 EAST, SALT LAKE BASE AND MERIDIAN

STATE PLANE COORDINATE SYSTEM PARAMETERS:

HORIZONTAL AND VERTICAL DATA WAS COLLECTED BY GPS AND CONVENTIONAL METHODS REFERENCING UTAH'S
TURN GPS (VRS) NETWORK. MAP SCALING PARAMETERS ARE DEFINED AS FOLLOWS:

PROJECT DATUM = NORTH AMERICAN DATUM OF 1983 (N.A.D. 83)
VERTICAL DATUM = NORTH AMERICAN VERTICAL DATUM OF 1988 (N.A.V.D. 88)
COORDINATE SYSTEM = U.S. STATE PLANE 1983, UTAH CENTRAL ZONE (4302) PROJECTED
TO GROUND, REFERENCING GEOID MODEL 18.

UNITS = US SURVEY FEET
FALSE NORTHING = 0000.00
FALSE EASTING = 0000.00
GROUND SCALE FACTOR = 1.0003152870
ELLIPSOID HEIGHT = 6703.565

SCALING LATITUDE = N 40° 40' 05.92870"
SCALING LONGITUDE = W 111° 30' 39.53994"

SURVEY CONTROL COORDINATES WERE OBTAINED USING STANDARD RTK (VRS) OBSERVATION METHODS.

CONTROL POINTS ARE SUBJECT TO THE EFFECTS OF SURFACE ACTIVITY AND SEASONAL MOVEMENTS. POINTS MAY
BE SUBJECT TO INTENTIONAL OR UNINTENTIONAL DAMAGE OR REMOVAL. CONTROL POINT POSITIONS SHOULD BE
FIELD VERIFIED PRIOR TO ANY SUBSEQUENT SURVEY OR CONSTRUCTION ACTIVITIES.



POINT	LATITUDE (N)	LONGITUDE (W)	NORTHING	EASTING	NAVD88 ELEV	DESCRIPTION
101	40° 40' 05.93"	111° 30' 39.48"	7412181.227	1637374.412	6754.20	3" MON SE COR S.5
105	40° 40' 05.90"	111° 30' 04.48"	7412177.823	1640071.196	6754.46'	R/C S1/4 S.4
111	40° 39' 13.87"	111° 30' 39.89"	7406913.293	1637341.850	-	3" MON SE COR S.8
500	40° 40' 05.63"	111° 30' 44.60"	7412151.293	1636979.995	6764.00'	SCRIBE
501	40° 40' 05.62"	111° 30' 35.55"	7412149.892	1637677.405	6751.67'	SCRIBE
502	40° 40' 06.46"	111° 30' 31.04"	7412234.575	1638024.838	-	SCRIBE
503	40° 40' 14.48"	111° 30' 28.47"	7413046.154	1638222.737	6735.63'	SCRIBE
504	40° 40' 18.09"	111° 30' 28.01"	7413412.053	1638258.306	-	SCRIBE
650	40° 39' 46.09"	111° 30' 47.86"	7410174.131	1636727.929	6811.26'	MAG NAIL
654	40° 39' 39.81"	111° 30' 05.23"	7409537.355	1640013.503	6813.16'	3.5" MON CTR S.9
660	40° 39' 40.30"	111° 31' 02.01"	7409587.358	1635637.971	-	SCRIBE
661	40° 39' 20.86"	111° 30' 43.25"	7407620.403	1637083.016	-	SCRIBE
662	40° 39' 20.88"	111° 30' 39.26"	7407622.130	1637390.628	6859.71'	SCRIBE
663	40° 39' 16.88"	111° 30' 34.37"	7407217.198	1637767.874	-	SCRIBE
664	40° 40' 16.85"	111° 30' 01.69"	7413286.009	1640286.585	6731.82'	SCRIBE
665	40° 40' 16.79"	111° 30' 07.55"	7413280.688	1639835.017	6734.08'	SCRIBE
666	40° 40' 04.97"	111° 29' 23.57"	7412084.557	1643223.634	-	MAG NAIL
667	40° 40' 05.39"	111° 29' 30.18"	7412126.880	1642714.540	6736.42'	SCRIBE
1000	40° 39' 11.99"	111° 30' 22.25"	7406722.613	1638701.893	-	SCRIBE
1001	40° 39' 14.80"	111° 30' 24.38"	7407007.175	1638537.265	6899.41'	SCRIBE
1002	40° 39' 35.03"	111° 30' 05.72"	7409053.598	1639975.839	6829.56'	SCRIBE
1003	40° 39' 37.48"	111° 30' 05.90"	7409301.814	1639962.222	-	SCRIBE
1200	40° 40' 18.71"	111° 30' 23.46"	7413474.323	1638609.302	-	NAIL & WASHER
1202	40° 40' 18.65"	111° 30' 21.22"	7413468.955	1638781.804	6731.65'	NAIL & WASHER
1204	40° 40' 17.76"	111° 30' 15.14"	7413378.140	1639249.773	6733.62'	NAIL & WASHER
1205	40° 40' 20.35"	111° 30' 15.09"	7413640.483	1639253.674	-	NAIL & WASHER
1206	40° 39' 44.94"	111° 31' 02.13"	7410057.090	1635628.844	6866.59	NAIL & WASHER
1207	40° 39' 45.90"	111° 30' 53.31"	7410154.295	1636308.348	-	NAIL & WASHER
1208	40° 39' 40.30"	111° 31' 02.01"	7409587.358	1635637.971	-	NAIL & WASHER
1209	40° 39' 45.37"	111° 30' 49.04"	7410100.455	1636637.344	6815.99'	NAIL & WASHER
1214	40° 39' 30.99"	111° 30' 17.61"	7408645.197	1639059.641	6839.49'	SCRIBE
1215	40° 39' 30.04"	111° 30' 20.54	7408549.019	1638833.515	6841.84'	NAIL & WASHER
1216	40° 39' 28.12"	111° 30' 19.76"	7408355.219	1638894.038	-	NAIL & WASHER
1217	40° 39' 56.46"	111° 29' 48.28"	7411222.461	1641319.960	-	NAIL & WASHER
1218	40° 39' 57.93"	111° 29' 46.14"	7411371.579	1641484.556	6760.03'	NAIL & WASHER

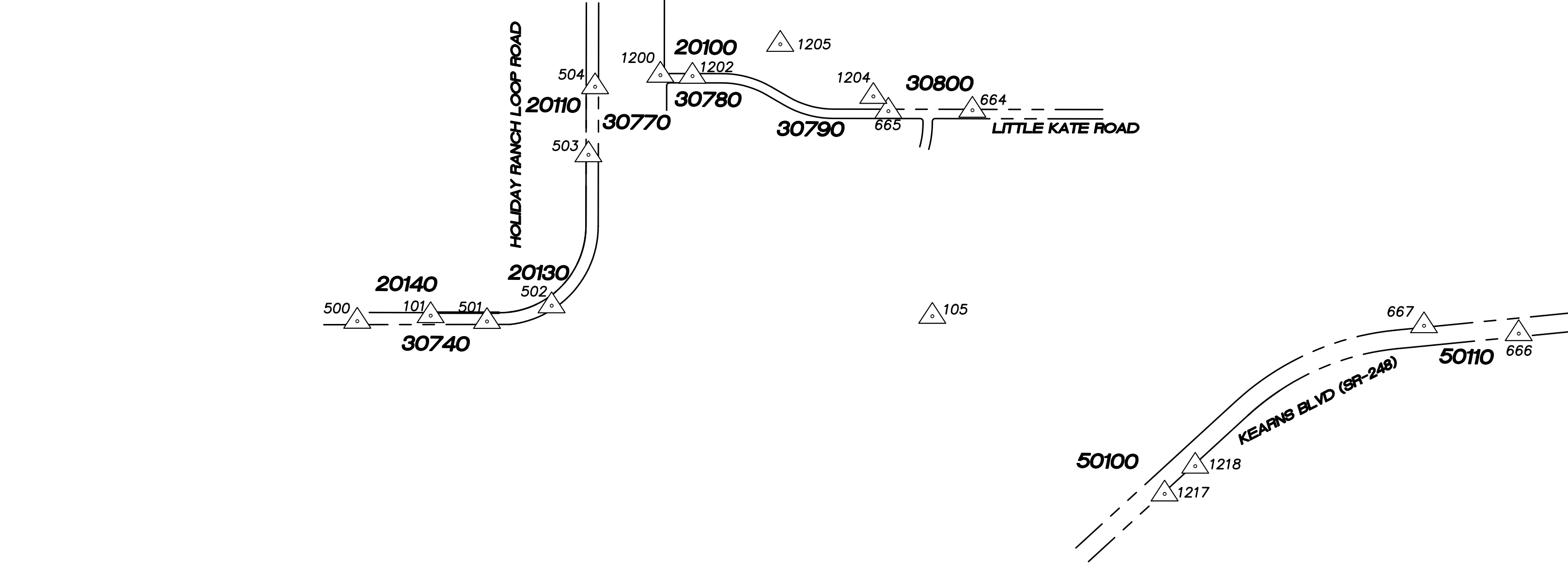

SPECIFICATIONS

DOCUMENT 00 01 01 – TITLE PAGE

**For
PARK CITY BUS STOP PROGRAM – PHASE 1
CP0025
MARCH 27, 2024**



CITY ENGINEER -- JOHN ROBERTSON, P.E.

PARK CITY MUNICIPAL CORPORATION (“PCMC”)
Park City, Utah

PROJECT MANUAL

FOR

**PARK CITY BUS STOP PROGRAM – PHASE 1
CP0025**

PREPARED BY

Park City Municipal Corporation
Engineering Division
445 Marsac Avenue
Park City, UT 84060

DOCUMENT 00 01 07 - SEALS PAGE

**PARK CITY BUS STOP PROGRAM – PHASE 1
CP0025**

PROJECT MANUAL PREPARED UNDER THE DIRECTION OF

John S. Robertson, P.E.
City Engineer
Park City Municipal Corporation
Engineering Division
445 Marsac Avenue
Park City, UT 84060
(435) 615-5073

DOCUMENT 00 01 10 - TABLE OF CONTENTS

**PARK CITY BUS STOP PROGRAM – PHASE 1
CP0025**

Reference Number	Title	No. of Pages
-----------------------------	--------------	-------------------------

PROCUREMENT AND CONTRACTING REQUIREMENTS

00 01 01	Project Title Page	1
00 01 07	Seals Page	1
00 01 10	Table of Contents	1
00 11 16	Invitation to Bid	3
00 21 13	Instructions to Bidders	10
00 22 13	Supplementary Instructions to Bidders	1
00 22 16	Supplementary Instructions (Park City Municipal Corporation)	1
00 41 00	Bid Form	4
00 43 00	Bid Schedule	14
00 43 36	Proposed Subcontractor Form	2
00 43 37	Work Under Contract Report	2
00 43 38	Bidder Status Report	1
00 61 13	Performance Bond	6
00 61 14	Payment Bond	5
00 62 11	Submittal Transmittal Form	4
00 62 16	Certificate of Insurance Form	1
00 73 10	Modifications to the General Conditions	4
00 73 15	Modifications to APWA and City Standard Plans	1
00 91 13	Addenda	1
13 34 19	Metal Building	1

Appendix A – FTA Clauses, Certifications, and Provisions for Construction Services

Appendix B – Park City Municipal Corporation Construction Agreement

Exhibit A - FTA Clauses, Certifications, and Provisions for Construction Services

Appendix C – DBE and Davis-Bacon Determination

Appendix D – Davis-Bacon Wages

END OF DOCUMENT

DOCUMENT 00 11 16 - INVITATION TO BID

PART 1 GENERAL

1.1 CONSTRUCTION CONTRACT

A. Bidders are invited to bid on the Construction Agreement named and numbered as:

PARK CITY BUS STOP PROGRAM – PHASE 1 CP0025

B. All questions regarding this solicitation shall be posted directly through the U3P website; questions or any other correspondence sent directly to city staff will not receive a response.

C. For assistance on U3P issues, contact Stormie Dawn via email at stormie.dawn@parkcityorg

1.2 DESCRIPTION OF WORK

A. The location of the work is:

Various Locations in Park City, Utah.

B. The work to be performed consists of furnishing and installing the equipment, facilities, services, and appurtenances indicated in the Contract Documents. The Work generally includes, but is not limited to, the following: street improvements including replacement of concrete flatwork, ADA ramps, and C&G; reclaimed aggregate with cement, replacement of pavement. The City has created separate Bid Schedules found in Document 00 43 00 and will award the work in accordance with available funds.

1.3 BIDDERS' QUALIFICATIONS

A. To demonstrate Bidder's qualifications to perform the Work, Bidder shall submit with its Bid (a) written evidence establishing its qualifications such as financial data, previous experience, and present commitments, and (b) the following additional information:

1. Evidence of Bidder's authority to do business in the State of Utah as well as in the City of Park City, Utah.
2. Bidder's state or other contractor license number, including Tax ID.
3. Evidence of three (3) projects of similar work and cost.

B. A Bidder's failure to submit required qualification information within the times indicated may disqualify Bidder from receiving an award of the Contract.

C. No requirement in this Article 1 to submit information will prejudice the right of Owner to seek additional pertinent information regarding Bidder's qualifications.

D. Bidder is advised to carefully review those portions of the Bid Form requiring Bidder's representations and certifications.

E. Bidders are not required to be pre-qualified for the Work.

1.4 BASIS OF BIDS

A. Bids shall be on a unit price basis. Unsealed or segregated Bids will not be accepted.

1.5 CONTRACT TIME

A. The Work will be Substantially Complete by October 31, 2024. Provisions concerning Contract Time are set forth in Section 7 of the Construction Agreement (Appendix B).

1.6 EXAMINATION AND PROCUREMENT OF DOCUMENTS

A. Complete sets of Contract Documents may be examined and obtained from the Utah Public Procurement Place (formerly SciQuest) website:

<https://bids.scquest.com/apps/Router/PublicEvent?CustomerOrg=StateOfUtah>

Search for Event Number: PCMC202425771

- B. To ensure that notification of addenda is received, BIDDERS must register with the Utah Public Procurement Place (U3P) website:

<https://solutions.scquest.com/apps/Router/SupplierLogin?CustOrg=StateOfUtah>

1.7 PRE-BID CONFERENCE

- A. A pre-bid conference will be held at 2:00 p.m. April 1, 2024, via Zoom. All contractors intending to submit a bid are required to attend to obtain relevant information concerning the project. Bidders are advised that information affecting drawings, specifications, conditions, scope of the Work, etc. may be discussed. Owner assumes no obligation to disclose information discussed at the pre-bid conference to Bidders who do not attend. Absent Bidders assume all risk of failure to attend.

1.8 BID SECURITY

- A. Bid security shall be furnished by a cashier's check or bid bond in the amount of five percent (5%) of the total bid price payable to Park City Municipal Corporation as a guarantee that the Bidder, if its Bid is accepted, will promptly execute the contract, provide evidence of insurance, and furnish a satisfactory, faithful performance bond in the amount of one hundred percent (100%) of the total bid price and a payment bond in the amount of one hundred percent (100%) of the total Bid price. A photocopy or facsimile transmission of bid security will not be accepted. Bid security will be returned to each unsuccessful Bidder after tabulation and award of the Construction Agreement.

1.9 BID LOCATION AND OPENING

- A. Bids will be accepted until 2:00 p.m. local prevailing time on Tuesday, April 16, 2024, for:

PARK CITY BUS STOP PROGRAM – PHASE 1

- B. Bids received after 2:00 p.m. will not be accepted.
- C. Electronic Bids must be submitted to Utah Public Procurement Place (U3P).
- D. Bids will be publicly opened virtually online via Zoom, at or about 2:15 p.m., local prevailing time, on Thursday April 13, 2023. Specific instructions will be found on U3P.

1.10 RIGHT TO REJECT BIDS

- A. Owner reserves the right to reject any or all bids or to waive any informality or technical error in any bid if Owner deems it to be in its best interest.

1.11 VALIDITY PERIOD FOR BIDS

- A. Bids shall remain valid for forty-five (45) days after the day of Bid opening. A Bidder who receives a Notice of Intent to Award and who withdraws his bid after Bid opening, but before expiration of said period, shall forfeit its bid security.

1.12 GOVERNING LAWS AND REGULATIONS

- A. This project requires the payment of Davis-Bacon wage rates. Prompt payment and payroll submittals will be required. See Appendix C UDOT DBE and Davis-Bacon Determination.
- B. Bidders on this Work will be subject to the applicable provisions of all federal, state, and local rules, laws, and regulations or orders.

1.13 AMERICANS WITH DISABILITIES (ADA)

- A. In compliance with Americans with Disabilities Act (“ADA”), the following information is provided: Fax Number 435-658-8937, TDD Number 385-215-5322, Contact person: John Robertson, City Engineer, City Engineer’s Office or by email at john.robertson@parkcity.org If assistance is required, please contact the above office at least seventy-two (72) hours before the bid opening.

1.14 REPRESENTATION REGARDING ETHICAL STANDARDS FOR CITY OFFICERS AND EMPLOYEES AND FORMER CITY OFFICERS AND EMPLOYEES

- A. A bid will not be accepted unless it contains the following representation.
- THE BIDDER, OFFEROR, OR CONTRACTOR represents that it has not:
1. Provided an illegal gift or payoff to a City officer or employee or former City officer or employee, or his or her relative or business entity.
 2. Retained any person to solicit or secure this contract upon an agreement or understanding for a commission, percentage, or brokerage or contingent fee, other than bona fide employees or bona fide commercial selling agencies for the purpose of securing business.
 3. Knowingly breached any of the ethical standards set forth in the City’s conflict of interest ordinance in the Park City Code; or
 4. Knowingly influenced, and hereby promises that it will not knowingly influence, a City officer or employee or former City officer or employee to breach any of the ethical standards set forth in the City’s conflict of interest ordinance in the Park City Code.

1.15 AWARD

- A. UDOT Civil Rights will review and approve the DBE commitment and/or good faith efforts made by the bidder selected by Park City Municipal Corporation prior to the award of the Construction Agreement. Bidders must submit DBE commitment at time of bid or evidence of a Good Faith Effort to be considered responsive.

END OF DOCUMENT

DOCUMENT 00 21 13 - INSTRUCTIONS TO BIDDERS

PART 1 GENERAL

1.1 DEFINED TERMS

- A. Terms used in the Bid Documents defined in Article 1.1 of the General Conditions will have the meanings indicated in the General Conditions.
- B. General Conditions: as published in Document 00 72 00 in the current edition of the Manual of Standard Specifications by the Utah Chapter of the American Public Works Association.
- C. Bidder: Bidder means a licensed contractor who submits a bid and furnishes a bid bond in response to the invitation to bid.
- D. Contractor: Contractor means a person who is awarded a contract through the procurement process.
- E. Engineer: Engineer means the City Engineer for Park City Municipal Corporation.
- F. Owner: Owner means Park City Municipal Corporation.
- G. Owner's Committee: Means staff from Park City Municipal Corporation involved with dispute resolution efforts.

1.2 COPIES OF BID DOCUMENTS

- A. Bidders must use complete sets of Bid Documents in preparing Bids. Owner and Engineer assume no responsibility for errors or misinterpretations resulting from the use of incomplete sets of Bid Documents.
- B. Bid Documents are made available to Bidder only for the purpose of obtaining Bids on the Work. No license or grant for any other use is given.
- C. Bid Document copyrights shall remain with Owner.

1.3 STANDARDS AND SPECIFICATIONS

- A. All provisions of the current edition of the Manual of Standard Specifications and Manual of Standard Plans published by the Utah Chapter of the American Public Works Association and PCMC 2021 Supplemental Standards and Specifications that apply to the Work are made a part of the Contract Documents by reference. Those publications are available on the web at <http://utah.apwa.net>. Where provisions of Federal clauses conflict with APWA or PCMC law and regulations, Federal clauses take precedence, then PCMC laws and regulations, then APWA. Where provisions from the current edition of the Manual of Standard Specifications and Manual of Standard Plans conflict with these documents or the Construction Agreement, the following order of precedence will apply:
 1. Construction Agreement takes precedence.
 2. These Bid Documents
 3. Project specific plans and specifications
 4. Park City 2021 Supplemental Standard Plans and Specifications
 - (a) Available at: <https://www.parkcity.org/departments/engineering-division>
 5. APWA provisions
 6. UDOT Standards and Specifications

1.4 PRE-BID CONFERENCE

- A. Representatives of Owner and Engineer will be present at a pre-bid conference to discuss the Project. Bidders are required to attend and participate in the conference. Engineer will transmit to all persons or agencies who have signed up to receive copies of the Bid Documents such Addenda as Engineer considers necessary in response to questions

arising at the conference. The location and time of the conference are identified in the Invitation to Bid (Document 00 11 16).

1.5 EXAMINATION OF SITE AND CONTRACT DOCUMENTS

- A. In General:** Bidders are permitted to converse with Engineer or Engineer's personnel having knowledge of the Project, Plans, Specifications, material sites, or conditions generally prevailing in the area of the Project to aid in pre-bid investigations. Owner is not bound by any statements or representations made by Engineer or Engineer's personnel before the Bid opening or award of the Construction Contract, nor for any assumptions or conclusions reached by a prospective Bidder as a result of such communication unless Engineer issues an Addendum to all prospective Bidders.
- B. Access to Site:** The lands upon which the Work is to be performed, and rights-of-way and easements for access thereto and other lands designated for use by Bidder in performing the Work are identified in the Contract Documents. All additional off-site lands and access thereto required for temporary construction facilities or storage of materials and equipment must be provided by Bidder.
- C. Contract Documents:** The submission of a Bid will constitute an incontrovertible representation by Bidder that Bidder has complied with every requirement of this Article 1.5; that without exception the Bid is premised upon performing and furnishing the Work required by the Contract Documents; and that the Contract Documents are sufficient in scope and detail to indicate and convey an understanding of all terms and conditions for performance and furnishing of the Work.
- D. Bidder's Obligations:** The submission of a Bid constitutes acknowledgement that Bidder has complied with all bidding instructions. It is the responsibility of each Bidder, before submitting a Bid, to:
 - 1. Examine the Contract Documents thoroughly;
 - 2. Visit the site to become familiar with local conditions that may affect the cost, progress, performance, or furnishing of the Work;
 - 3. Consider federal, state, and local laws and regulations that may affect the cost, progress, performance, or furnishing of the Work;
 - 4. Study and carefully correlate Bidder's observations with the Contract Documents; and
 - 5. Identify and notify Engineer in writing of all specific conflicts, errors, or discrepancies in the Contract Documents, and of any doubts of Bidder about their meanings. The failure or omission of any Bidder to receive or examine any form, instrument, Addendum, or other document, visit the site and become acquainted with conditions there existing, or attend the pre-bid conference, shall in no way relieve any Bidder from obligations with respect to Bidder's Bid or to the Construction Agreement.
- E. Deviations from the Terms of the Contract Documents:** Owner will not accept any deviations whatsoever from the printed terms of the Contract Documents, except by Addendum or Change Order.

1.6 PHYSICAL CONDITIONS

- A. In General:** Before submitting a Bid, each Bidder is responsible for review of Owner's explorations, tests, and data concerning surface conditions, subsurface conditions, and Underground Facilities at or contiguous to the site, or otherwise, that may affect cost, progress, performance, or furnishing of the Work in accordance with the time, price, and other terms and conditions of the Contract Documents.

- B. Underground Facilities: Information and data indicated in the Contract Documents regarding Underground Facilities at or contiguous to the site is based upon information and data furnished to Owner and Engineer by owners of such Underground Facilities. Owner does not assume responsibility for the accuracy or completeness thereof other than as provided in paragraph 4.3(A)(2) of the General Conditions or unless expressly provided in the Modifications to the General Conditions (Document 00 73 10).
- C. Additional Explorations: On request in advance, and if possible, Owner will provide to each Bidder access to the site to conduct any explorations and tests as each Bidder deems necessary for submission of a Bid. Bidder shall obtain permits, fill all holes, and clean up and restore the site to its former condition upon completion of such explorations. Bidder shall indemnify and save Owner harmless during and after the performance of additional explorations.
- D. Modifications to the Contract Documents: Provisions concerning the adequacy of the data furnished for subsurface structures and underground facilities and the possibility of changes in the documents due to differing conditions appear in Articles 4.2 and 4.3 of the General Conditions.

PART 2 BIDDING PROCEDURES

2.1 INTERPRETATIONS AND ADDENDA

- A. All requests for interpretation of the Contract Documents shall be made in writing and delivered to Engineer **no later than seven (7) calendar days before the Bid opening**. If required, Engineer will send a written interpretation to all persons receiving a set of Bid Documents in the form of a written Addendum. If Engineer doesn't respond to a Bidder's request for interpretation, Bidder shall not rely on any interpretation in the request that is contrary to the intent and terms of the Contract Documents.
- B. Owner will not be responsible for any explanations or interpretations, except those duly issued in the form of a written Addendum.
- C. Addenda may also be issued to modify the Bidding Documents as deemed advisable by Engineer.
- D. Any Addendum so issued during the time of bidding shall be deemed to be included in the Bid. All Addenda shall become a part of the Contract Documents.
- E. Except to cancel the Bid opening, no Addendum shall be issued within forty-eight (48) hours before the Bid opening.
- F. **ANY INQUIRIES RELATED TO INDEMNIFICATION OR INSURANCE PROVISIONS CONTAINED IN PARK CITY MUNICIPAL CORPORATION'S STANDARD AGREEMENT MUST BE SUBMITTED TO PARK CITY MUNICIPAL CORPORATION NO LATER THAN THE PROPOSAL/SUBMITTAL DEADLINE. PARK CITY MAY, IN ITS SOLE DISCRETION, CONSIDER SUCH INQUIRIES. ANY CHANGES TO PARK'S CITY'S STANDARD INSURANCE AND INDEMNIFICATION PROVISIONS SHALL BE APPROVED IN PARK CITY'S SOLE DISCRETION.**

2.2 EQUIPMENT AND MATERIAL OPTIONS BEFORE OPENING

- A. If a Bidder or Supplier wishes to use items of equipment or materials other than those identified in the Contract Documents, Bidder or Supplier shall submit a written request for approval to Engineer at least ten (10) days before the date set for the Bid opening.

- B. The procedure for submission of any such request shall be as follows: electronically submit 1) a written request and technical brochures; and 2) a statement of variances. The statement of variances must list all features of the proposed substitution that differ from the Contract Documents and must further certify that the substitution has no other variant features. The brochure and information submitted must be clearly marked showing make, model, size, options, and any other features and must include sufficient evidence for Engineer to evaluate each feature listed as a variance. If after installing the substituted product, an unlisted variance is discovered, Contractor shall immediately replace the product with a specified product at no cost to Owner.
- C. Any approval of such a request by Engineer must be made not later than forty-eight (48) hours before the Bid opening. Engineer's failure to approve by such time shall be deemed a denial of the request.
- D. Any such approval is at the sole discretion of Engineer and will be in the form of an Addendum, issued to all Bidders holding Bid Documents, indicating that the additional equipment or materials are approved as equal to those specified for the Project.

2.3 BID SECURITY

- A. **Delivery of Bid Security:** Bidders must deliver Bid security, in the form of either a Bid Bond or a cashier's check, to Owner at the time they deliver their Bid. If Bid Security is not delivered with the Bid, the Bid shall not be read.
- B. **Amount of Bid security:** The Bid security amount must equal at least five percent (5%) of the total amount of the Bid. The total amount of the Bid shall be the sum of all items of the Bid, constituting the maximum amount of the possible award to the Bidder.
- C. **Bid Bond:** If a Bid Bond is used, a photocopy or facsimile transmission of the Bond will not be accepted. The Bond shall guarantee that the Bidder, if awarded the Work, will promptly enter into the Construction Agreement to perform the Work in the manner required by the Contract Documents.
- D. **Cashier's Check:** If a cashier's check is used, the cashier's check must be made payable to Park City Municipal Corporation. A photocopy or facsimile transmission of the check will not be accepted. Personal or company checks will not be accepted.
- E. **Return of Bid Security:** Owner will return the Bid security to all Bidders by the earlier of forty-five (45) calendar days after the date of the Bid opening and seven (7) calendar days after the effective date of the Construction Agreement. The liability of Owner in regards to cashier's checks shall be limited only to the return of the checks.
- F. **Default:** If the Bidder fails, within the time limit described in Article 3.6(A), to enter into the Construction Agreement and to deliver to Owner a Performance Bond, Payment Bond, or any other Bonds or documents required by the Contract Documents after Notice of Intent to Award by Owner, the Bidder shall forfeit the amount of the Bid Bond or cashier's check as liquidated damages to Owner.

2.4 CONTRACT TIME

- A. Provisions concerning Contract Time are set forth in the Standard Construction Agreement (Appendix B).

2.5 LIQUIDATED DAMAGES

- A. Provisions concerning liquidated damages are set forth in the Standard Construction Agreement (Appendix B).

2.6 BID FORM

- A.** The Bid Form (Document 00 41 00) identifies all forms comprising the Bid Documents. Additional copies may be obtained from Engineer.
- B.** All names must be typed or printed under or near the signature. The signature must be an original signature.
- C.** The Bid must contain an acknowledgment of receipt of all Addenda. The Addenda numbers must be filled in on the Bid Form.
- D.** The Bidder's address and telephone number for communications regarding the Bid must be shown on the first page of the Bid Form.
- E.** The Bidder shall make no stipulations or alterations on the Bid forms. The Bidder must use only the Bid Form and Bid Schedules found in the Contract Documents (unless updated forms are included in an addendum, in which case the Bidder shall use the updated forms).
- F.** Owner may waive any failure to comply with the requirements of this paragraph 2.6 if Owner determines that such failure (1) is not material to the terms of Owner's Bid Documents and process and does not render the Bid non-compliant with laws and regulations pertaining to bidding; or (2) involves ministerial or minor informalities that are evident from the Bid Documents or that can be waived without prejudice to other Bidders and that do not have a substantial effect on price.

2.7 BID SCHEDULE

- A.** Any work or material that is specified in the Contract Documents or that is necessary because of the nature of the Work, but that is not listed separately in the Bid Schedule (Document 00 43 00), shall not be measured or paid for separately. The cost of such work or material shall be considered as included in the Contract Price.
- B.** All blanks on the Bid Schedule (Document 00 43 00) must be completed electronically or in ink. If applicable, furnish both the unit and the total costs for each item. Bid total shall be stated in figures and numbers. Any corrections, alterations or erasures made by the Bidder to the information the Bidder entered on the Bid Schedule shall be initialed in ink by the Bidder. Owner may waive any failure to comply with the requirements of this paragraph if Owner determines that such failure (1) is not material to the terms of Owner's Bid Documents and process and does not render the Bid non-compliant with laws and regulations pertaining to bidding; or (2) involves ministerial or minor informalities that are evident from the Bid Documents or that can be waived without prejudice to other Bidders and that do not have a substantial effect on price.

2.8 SUBMISSION OF BIDS

- A.** Bids must be submitted at the time and place indicated in the Invitation to Bid (Document 00 11 16).
- B.** Alternate bids, other than those called for in the Bid form, will not be considered.
- C.** No oral, telegraphic, telephonic, or modified bids will be considered. Owner will not consider any attempted modification of a Bid written or made on the outside of the envelope containing the Bid.

2.9 MODIFICATIONS AND WITHDRAWAL OF BIDS

- A.** At any time before the Bid opening, Bids may be modified or withdrawn if a written notice of the modification or withdrawal, as the case may be, is signed by Bidder and delivered to the place where Bids are to be submitted.

- B. Within two (2) business days after Bids are opened, any Bidder may file written notice with Owner that there was a substantial mistake made in the preparation of its Bid. Bidder must thereafter promptly demonstrate Bidder's mistake to the reasonable satisfaction of Owner. If Owner agrees, Bidder may withdraw its Bid and the Bid security will be returned to Bidder.

2.10 OPENING OF BIDS

- A. Bids will be opened and read aloud publicly unless obviously non-responsive. An abstract of the amounts of the base schedule of prices and any alternate schedules will be made available for review after the opening of Bids.
- B. Any Bids received after the time specified in the Invitation to Bid (Document 00 11 16) will be returned unopened.

2.11 BIDS SUBJECT TO ACCEPTANCE FOR 45 DAYS

- A. Subject to Paragraph 2.3(E) hereof, Bids remain subject to acceptance for forty-five (45) days after the day of the Bid opening. Owner may, in its sole discretion, release any Bid and return the Bid security before that date. Owner and Bidder may agree to extend the forty-five (45) day deadline.

2.12 NONDISCRIMINATION IN EMPLOYMENT

- A. Work under this Bid will obligate the Bidder and Subcontractors not to discriminate in employment practices.
- B. Bidders must, if requested, submit a compliance report concerning employment practices and policies in order to maintain their eligibility to receive the award of the Construction Agreement.
- C. Equal opportunity employment shall be reflected in the racial and sexual composition of Bidder's work force and Owner urges an affirmative action program to overcome under-utilization.
- D. Bidders are advised that the Construction Agreement and its performance are subject to the applicable provisions of all laws and regulations. Bidder will be obligated, upon written request, to give all applicable assurances of compliance in connection therewith.
- E. If federal nondiscrimination requirements are applicable, Bidder must be fully knowledgeable and comply with such requirements. Refer to Community Development Block Grant Supplementary Conditions ("CDBG") (Document 00 73 12) or Federal Aviation Administration Supplementary Conditions as applicable.

2.13 SECTION 3, HOUSING AND URBAN DEVELOPMENT ACT OF 1968

- A. If Work under this Bid is funded with a federal CDBG the requirements of Section 3 of the Housing and Urban Development Act of 1968 may apply to the Bidder and its Subcontractors. Owner encourages the use of the State of Utah Section 3 to register for all subcontracting [http://housing.utah.gov/section3/HUD Section 3.html](http://housing.utah.gov/section3/HUD%20Section%203.html).
- B. Bidder will be obligated to give all applicable assurances of compliance in connection with this Section 2.13 at any time.

PART 3 AWARD OF CONSTRUCTION AGREEMENT

3.1 QUALIFICATIONS OF BIDDERS

- A. Within seven (7) calendar days after Engineer's request, a Bidder whose Bid is under consideration for award shall submit to Engineer any of the following information requested by Engineer. Engineer may request like information regarding Bidder's Subcontractors or Bidder's Suppliers:
1. A current financial statement for the Work (as provided to the bonding company);
 2. A chronological list of "completed" construction work done by Bidder during the last three (3) years, including project name, address, owner, contract name, and current telephone number;
 3. Work Under Contract Report (Document 00 43 37);
 4. The proposed organizational structure for the project: firm ownership, project manager, progress scheduler, and Contractor's Resident Superintendent's resume;
 5. Owned and rented equipment that is to be used to do the Work;
 6. Investigations, arbitrations, litigation, or claims that are pending, threatened, settled, or disposed of within the last three (3) years;
 7. Evidence of ability to perform and complete the Work in a manner and within the time limit specified. As a minimum, identify specific projects similar to the Work in physical size, cost, and commercial nature. If the work experiences of the project manager and Resident Superintendent designated to construct this project are different than that of Bidder, provide resumes of their work history. Include their actual project titles and indicate their actual responsibilities on each given project;
 8. Names of three (3) projects of similar size and nature that the Resident Superintendent has completed. Include the name, address, and telephone number of the office contracting for each project.
 9. Information so Owner's Labor Relations Specialist can certify that Bidder has an acceptable Utilization Plan that offers economic opportunities to low and very low income persons and that Bidder qualifies as a Section 3 Contractor; and
 10. Such other data as may be called for in the Supplementary Instructions to Bidders (Document 00 22 13) (if any).
 11. All key trade certifications associated with all bid items and contract documents.
- B. Bidder must comply with Utah Code section 63G-2-309 when submitting confidential information.
- C. Untimely response by Bidder will release Owner of any obligation to further negotiate or consider Bidder's Bid.

3.2 EVALUATION OF BIDS

- A. Owner reserves the right: (1) to reject any and all Bids; (2) to waive minor informalities in the Bid Schedule and elsewhere so long as the informalities (a) are not material to Owner's Bid Documents and process and do not render the Bid non-compliant with laws and regulations pertaining to bidding or (b) involve ministerial or minor informalities that are evident from the Bid Documents or that can be waived without prejudice to other Bidders and that do not have a substantial effect on price; (3) to negotiate and agree to contract terms with the successful Bidder; and (4) to disregard non-conforming, non-responsive, unbalanced, or conditional Bids.

- B.** Owner reserves the right to reject any Bid if Owner believes that it would not be in the best interest of the Project or Owner to make an award to that Bidder. Such rejection may be because the Bid is non-responsive, or Bidder is unqualified or of doubtful ability, or Bidder's Resident Superintendent is unqualified or of doubtful ability, or the Bid or Bidder fails to meet any other pertinent standard or criteria established by Owner in the Supplementary Instructions to Bidders (Document 00 22 13).
- C.** Owner will consider the qualifications of Bidder and such alternates, prices, and other data as may be requested in the Bid Form (Document 00 41 00), Bid Schedule (Document 00 43 00), or written requests issued prior to Owner's Notice of Intent to Award the Construction Agreement. Owner will consider Bidder's compliance with the Park City Code. See Document 00 22 16 Supplementary Instructions to Bidders.
- D.** Owner may consider the qualifications and experience of Subcontractors, Suppliers, and other persons and organizations proposed for portions of the Work as provided in the Proposed Subcontractor Form (Document 00 43 36). Owner will consider Bidder's compliance with the Park City Code. See Document 00 22 16 Supplementary Instructions to Bidders.
- E.** Owner may consider the operating costs, maintenance requirements, performance data, and guarantees of materials and equipment when such data is required to be submitted prior to the Notice of Intent to Award the Construction Agreement.
- F.** To establish qualifications of Bidder, Owner may request such data indicated in Section 3.1 of this document and conduct such investigations as Owner deems appropriate.
- G.** If the Construction Agreement is to be awarded, it will be awarded to the most responsive and lowest, qualified, responsible Bidder as determined by Owner. Alternates may be accepted depending upon availability of Owner funds. Bid alternates will be considered in determining the most responsive, lowest, qualified, and responsible Bidder.
- H.** Owner will evaluate Bid Schedules as follows:
 - 1.** Owner will resolve discrepancies in the multiplication of quantities of Work items and unit prices in favor of the unit prices.
 - 2.** Prices written out in words shall govern over prices written out in numbers.
 - 3.** Owner will resolve discrepancies between the indicated sum of any column of figures and the correct sum thereof in favor of the correct sum.
 - 4.** Bids shall not contain any recapitulations of or changes in the work to be done.
 - 5.** Owner may accept a Bid despite obvious errors in a Bid Schedule, such as a failure to include unit prices or a misplaced decimal point, as long as Owner reasonably can discern the intention of Bidder as to the amounts to be bid.
 - 6.** Owner has determined that the health, safety, and general welfare of the citizens of Park City are reasonably furthered by Owner's procurement requirements.
- I.** Owner reserves the right to review or audit any information provided by Bidder to make its evaluation. Bidder shall provide or furnish access to any necessary records or other information in order to permit Owner to verify Bidder's certifications. Bidder shall provide or furnish access to such records and information no later than three (3) business days after Owner issues a written request for the same.

3.3 SUBCONTRACTORS, SUPPLIERS AND OTHERS

- A.** Bidder shall not subcontract more than fifty percent (50%) of the dollar value of the total contemplated Work (exclusive of the supply of materials and equipment to be incorporated in the Work) without Owner's written approval.
- B.** Conflict of interest restrictions pertaining to Subcontractors are described in paragraph 6.5(H) of the General Conditions.

3.4 CONTRACT SECURITY AND OTHER SUBMITTALS

- A. Performance Bond (Document 00 61 13) and Payment Bond (Document 00 61 14):** Owner's requirements as to Performance and Payment Bonds are as set forth in the Modifications to General Conditions (Document 00 73 10). Specific requirements are set forth in the Performance Bond (Document 00 61 13) and the Payment Bond (Document 00 61 14).
 - 1.** Bidder should carefully examine the form of the Bonds.
 - 2.** When the successful Bidder delivers the executed Construction Agreement to Owner, it must be accompanied by the required Performance and Payment Bonds (using Documents 00 61 13 and 00 61 14, respectively).
- B. Proposed Subcontractor Form (Document 00 43 36):** Bidder must provide this report form to Owner within twenty-four (24) hours after Engineer's request. See Bid Form, paragraph 1.5(B) (Document 00 41 00) for additional information. The form shall list the name and address of each Subcontractor who will perform work or labor or render service to Bidder at the site of the Work, or a Subcontractor who, off the job site, will specially fabricate a portion of the Work or improvement according to detail Drawings. In each instance, the nature and extent of any Work to be subcontracted in an amount in excess of two percent (2%) of the Bid sum shall be described. Bidder must have the written consent of Owner to substitute for any of the Subcontractors or Suppliers designated or to employ any Subcontractor or Supplier that is not listed.
- C. Bidder Status Report (Document 00 43 38):** Bidder must submit the completed form upon Engineer's request or after Bidder receives the Notice of Intent to Award.
- D. Other Information:** When a determination has been made to award the Construction Agreement, Bidder is required, before the award or after the award, or both, to furnish such other information as Engineer requests.

3.5 ADJUSTMENTS TO THE COST OF THE WORK AFTER OPENING OF BIDS

- A.** The Contract Price identified in the Construction Agreement (Appendix B) represents the Cost of the Work that is to be paid by Owner to Contractor. Adjustments to the Contract Price that are agreed to between Owner and the successful Bidder shall be made in writing and signed by Owner and Contractor.

3.6 SIGNING OF AGREEMENT

- A.** After Owner gives Notice of Intent to Award the Construction Agreement to the successful Bidder, Bidder shall electronically sign and return the Agreement (Appendix B) and attached documents to Owner within ten (10) days with the required Bonds; the Owner in its discretion may allow a longer period. A copy of the executed original will be available to Bidder.
- B.** Transfers, delegations, or assignments of interests in the Contract Documents are prohibited, unless prior written authorization is received from Owner.

- C. At and from the time of Bidding through the completion of the Work, Bidder shall be properly licensed to do the Work and shall be in compliance with the license laws of the State of Utah, Park City and Summit County.

PART 4 MISCELLANEOUS

4.1 EQUIPMENT AND MATERIAL OPTIONS AFTER BID OPENING

- A. The Construction Agreement, if awarded, will be on the basis of materials and equipment described in the Drawings, Specifications, and any Addenda.
- B. The procedure for submitting an application for substitution after the effective date of the Construction Agreement is set forth in Article 6.4 of the General Conditions.

END OF DOCUMENT

DOCUMENT 00 22 13 - SUPPLEMENTARY INSTRUCTIONS TO BIDDERS

Add the following paragraph to Article 3.3.

3.3 SUBCONTRACTOR, SUPPLIERS AND OTHERS

C. The following firms, that have been under contract to the Owner in the design phase of the Work, shall not be used as subcontractors by the Contractor.

1. Materials Testing Subcontractor: _____.
2. Surveying Subcontractor: _____.
3. Other: _____.
4. Other: _____.
5. Other: _____.
6. Other: _____.
7. Other: _____.
8. Other: _____.

Add the following article to Part 4.

4.2 PARTNERING

- A. Refer to APWA Section 01 31 20 for description of partnering requirements.
- B. Owner's consultants listed in this project manual will be partners to the project.

END OF DOCUMENT

DOCUMENT 00 22 16 - SUPPLEMENTARY INSTRUCTIONS (PARK CITY MUNICIPAL CORPORATION)

PART 1 GENERAL

1.1 Utah Department of Transportation Encroachment Permit.

A. A UDOT Encroachment Permit shall be secured, as required by Utah Code Section 72-7-102, by the Contractor, at Contractor's sole expense. The agency responsible for issuing the permit is the Utah Department of Transportation. Refer to UDOT's webpage (<https://www.udot.utah.gov/connect/business/permits/encroachment-permits/>) for permit instructions.

B. Maintenance of Traffic

- 1.** With approval from UDOT and Park City Municipal Corporation, Contractor may adjust travel lanes on SR-224 and SR-248 to perform work adjacent to the roadway; lanes may be shifted to utilize the two-way-left-turn lanes to create work space

END OF DOCUMENT

DOCUMENT 00 41 00 - BID FORM

PART 1 GENERAL

1.1 BIDDER

- A. Name: _____
- B. Address: _____

- C. Telephone number: _____
- D. Email address: _____
- E. Tax identification number: _____
- F. Bidder holds license number _____, issued by the Utah State Department of Commerce, Division of Occupational and Professional Licensing. Bidder is licensed to practice as a _____ Contractor. The license expiration date is the ___ day of _____, 20__.

1.2 NOTICE

A. Pursuant to Section 58-55-501(8), Utah Code Annotated (UCA), it is unlawful to submit a bid for any work for which a license is required under Chapter 55 of Title 58, UCA, by a person or other business entity not licensed or excepted from licensure as a contractor under Chapter 55 of Title 58, UCA. Pursuant to Section 58-55-503(1), UCA, contracts for the work may not be awarded to any person or other business entity that violates Sections 58-55-501(8) UCA, in submitting its Bid.

1.3 PROJECT NAME

**A. PARK CITY BUS STOP PROGRAM – PHASE 1
CP0025**

1.4 ADDENDA

A. Bidder hereby acknowledges receipt of the following Addenda.

- _____ (list Addenda numbers here)
- _____ (list Addenda numbers here)
- _____ (list Addenda numbers here)

1.5 SUBMITTALS

A. With Bid:

- 1. This Bid Form (Document 00 41 00).
- 2. Bid Schedule (Document 00 43 00) including Schedule A items and Schedule B items
- 3. Bid bond.
- 4. Federal Certifications (Exhibit A)
- 5. DBE Commitment or Evidence of a Good Faith Effort
- 6. Document 00 43 36: Proposed Subcontractor Form.

B. Due diligence letter to Bidder: If Bidder receives a due diligence letter from Owner after bid opening, Bidder must submit the following documents to Owner after Engineer’s request.

- 1. Document 00 43 37: Work Under Contract Report.

2. Document 00 43 38: Bidder Status Report.
 3. Other information requested and as defined in Sections 3.1 and 3.4(D) of Document 00 21 13.
- C. After Notice of Intent to Award:** If Bidder receives a notice of intent to award the Contract from Owner after bid opening, Bidder must submit the following documents to Owner.
1. Appendix B: Construction Agreement.
 2. Document 00 61 13: Performance Bond.
 3. Document 00 61 14: Payment Bond.
 4. Document 00 73 10: Applicable Insurance Certificate.
- D. At the preconstruction meeting:** If the Documents noted below are included in the project manual, Bidder must submit the following documents to Owner.
1. Section 3 Business Certification (Document 00 43 42).
 2. Current Employee Information (Document 00 43 43).
- E. Prior to Final Payment:** If the Document noted below is included in the project manual, Contractor must submit the following document to Owner.
1. Section 3 Report Form (Document 00 43 44).

1.6 DEFINITIONS

- A. Bid Documents:** The Bid Documents consist of the Invitation to Bid, the Instructions to Bidders, any Supplementary Instructions to Bidders, this Bid form, any supplements (or post-bid supplements), the Bid Schedule, any data listed by and limited to the provisions in the Geotechnical Data Document, and the Bid Bond.
- B. Bid Bond:** AIA Document A310 as published by the American Institute of Architects, 1736 N. Y. Ave. N. W. Washington, D.C. 20006 or one substantially the same and acceptable to Owner.

PART 2 COVENANTS

2.1 BIDDER TO ENTER INTO AN AGREEMENT

- A. In General:** Bidder agrees, if this Bid is accepted, to enter into a Construction Agreement in the form of all Documents listed in Appendix B with Owner to perform and furnish all Work specified or indicated in the Contract Documents at the Contract Time and Contract Price.
- B. Bidder Accepts Terms and Conditions**
1. Bidder accepts all of the terms and conditions of the Bid Documents, including without limitation those dealing with the disposition of Bid security.
 2. Bidder must pick up, sign, and submit, the required number of copies of the Agreement (Appendix B) with the Bonds and other documents required by the Agreement within (ten) 10 days (or such longer period of time that Owner in its discretion may allow) after the date of Owner's Notice of Intent to Award the Construction Agreement.

2.2 REPRESENTATION OF BIDDER

- A. In submitting this Bid, Bidder represents, as more fully set forth in the Instructions To Bidders (Document 00 21 13), that:**
1. **Nature of the Work:** Bidder has become familiar with the nature and extent of the Contract Documents, Work, site, locality, and all local conditions and laws and

regulations that in any manner may affect cost, progress, performance, or furnishing of the Work.

2. **Surface and Subsurface Conditions:** Bidder has studied carefully all reports and drawings of subsurface conditions and drawings of physical conditions that are identified in the Geotechnical Data (Document 00 31 32) (if any).
3. **Underground Utilities:** Bidder has reviewed and checked all information and data shown or indicated on the Contract Documents with respect to existing Underground Facilities at or contiguous to the site.
4. **Bidder Investigation:** Bidder has correlated the results of all observations, examinations, investigations, explorations, tests, reports, and studies with the terms and conditions of the Contract Documents.
5. **Discrepancy Resolutions:** Bidder has given Engineer written notice of all conflicts, errors, or discrepancies that Bidder has discovered in the Contract Documents and acknowledges that all written resolutions thereof issued by Engineer before Bid opening, are acceptable to Bidder.

2.3 OWNER'S RIGHTS AT BID AWARD

- A. Bidder agrees that Owner has the right to reject this Bid or to award the Work or any part thereof listed in Schedule A or Schedule B to the undersigned at the prices stipulated. Bidder agrees to make no claim for damages for such rejection or award.
- B. If the Bid is rejected, then the Bid security shall be returned to Bidder.
- C. If the Bid is accepted, Owner shall notify Bidder of Owner's intent to award the Construction Agreement to Bidder. Bidder shall have ten (10) days (or such longer period of time that Owner in its discretion may allow) to sign and return the Agreement (Appendix B) to Engineer. If Bidder fails to sign the Agreement, the Bid security, at Owner's option, shall be claimed and cashed and the amount thereof paid to Owner as liquidated damages for the failure of Bidder to comply with the terms of the Bid.
- D. Bidder agrees that the Bid may be rejected if the submittals listed in this Document or the Notice of Intent to Award are not submitted within the time listed in the Notice of Intent to Award (or described in Section 2.3(C) of this Document).

2.4 NON-COLLUSION; ETHICS

- A. Bidder represents that the Bid is genuine. The Bid is not made in the interest of or on behalf of any undisclosed person, firm, or corporation.
- B. Bidder has not directly or indirectly induced or solicited any other Bidder to submit a false or sham Bid.
- C. Bidder has not solicited or induced any person, firm, or corporation to refrain from bidding.
- D. Bidder has not sought by collusion to obtain for itself any other advantage over any separate Bidder or over Owner.

E. REPRESENTATION REGARDING ETHICAL STANDARDS FOR CITY OFFICERS AND EMPLOYEES AND FORMER CITY OFFICERS AND EMPLOYEES

Bidder represents that it has not:

1. Provided an illegal gift or payoff to a City officer or employee or former City officer or employee, or his or her relative or business entity.
2. Retained any person to solicit or secure this contract upon an agreement or understanding for a commission, percentage, or brokerage or contingent fee, other

than bona fide employees or bona fide commercial selling agencies for the purpose of securing business.

3. Knowingly breached any of the ethical standards set forth in the City's conflict of interest ordinance in the Park City Code; or
4. Knowingly influenced, and hereby promises that it will not knowingly influence, a City officer or employee or former City officer or employee to breach any of the ethical standards set forth in the City's conflict of interest ordinance in the Park City Code.

2.5 BID PRICING

- A. Bidder will complete the Work for the prices listed in the Bid Schedule (Document 00 43 00). Bidder agrees that quantities for Unit Price Work are not guaranteed. (Refer to Article 11.7 of the General Conditions (Document 00 72 00)).

2.6 SUBSTANTIAL COMPLETION, PROJECT COMPLETION, AND LIQUIDATED DAMAGES

- A. Bidder agrees that the Work will be Substantially Complete and ready for Final Inspection on or before the expiration of the Contract Time indicated in the Construction Agreement (Appendix B).
- B. Bidder agrees that the Work will be complete and ready for final payment in accordance with Article 14.9 of the General Conditions (Document 00 72 00) on or before the expiration of the term indicated in the Agreement.
- C. Bidder accepts the provisions of the Agreement (Appendix B) as to liquidated damages in the event of failure to complete the Work on time and in accordance with the Contract Documents.

PART 3 EXECUTION

3.1 EFFECTIVE DATE

- A. Bidder executes this Bid and declares it to be in effect as of the ____ day of _____, 2024.

3.2 BIDDER'S SUBSCRIPTION

- A. Bidder's Signature: _____
- B. Please print Bidder's name here: _____
- C. Title: _____

END OF DOCUMENT

DOCUMENT 00 43 00 - BID SCHEDULE

PART 1 GENERAL

1.1 DOCUMENT INCLUDES

A. PRICE SCHEDULE A

Bid Item #	Item #	Item Description	Quantity	Unit	Unit Price	Cost
1	1100001	Mobilization and Demobilization	1	LSUM		
2	1100002	Traffic Control	1	LSUM		
3	1100009	Survey	1	LSUM		
4	2301001	Roadway Excavation	431	Cyd		
5	023167020	Roadway Excavation (Plan Quantity) (UDOT)	266	Cyd		
6	022217050	Remove Tree (UDOT)	1	Each		
7	2402001	Remove Drainage Structure	1	Each		
8	2501001	Remove Asphalt Pavement	728	Syd		
9	2503002	Remove Concrete Pavement	34	Syd		
10	2503998	T-Patch Milling	70	Syd		
11	022217165	Remove Asphalt Pavement (UDOT)	352	Syd		
12	2601001	Remove Sidewalk	34	Syd		
13	2603001	Remove Curb and Gutter	387	Ft		
14	028917285	Relocate Sign Less Than 20 Square Feet (UDOT)	7	Each		
15	2841001	Remove Pavement Marking	70	Ft		
16	2999001	Remove Existing Bus Stop Amenity	2	Each		
17	2999002	Remove Existing Bus Stop Shelter	1	Each		
18	3101001	Untreated Base Course	173	Cyd		
19	027217020	Untreated Base Course (UDOT)	51	Cyd		
20	3201001	Granular Borrow	106	Cyd		
21	020567015	Granular Borrow (UDOT)	102	Cyd		

22	3501001	Relocate Landscaping Boulder	19	Each		
23	3501002	Landscaping - Gravel Mulch	17	Syd		
24	3501003	Landscaping - Mulch	63	Syd		
25	3501004	Landscaping - Turf	10	Syd		
26	3501005	Landscaping - Drought Tolerant Grasses	197	Syd		
27	4101003	Drainage Pipe - 15 inch, Reinforced Concrete	109	Ft		
28	4201001	4' Standard Manhole, 44" Frame and Cover	2	Each		
29	4201002	Catch Basin - Single Grade	2	Each		
30	4201010	Drainage Structure Cover Adjust	1	Each		
31	018927041	Reconstruct Valve Box - Lower (UDOT)	1	Each		
32	4401101	Landscaping - Irrigation	1	LSUM		
33	027417050	HMA - 1/2 Inch (UDOT)	265	Ton		
34	027437040	HMA - 1/2 Inch, Bike/Ped Path (UDOT)	17	Ton		
35	6101002	Sidewalk, Concrete, 6 inch	1714	Sft		
36	6101010	Colored Concrete, Crosswalk	239	Sft		
37	6101103	Corner Curb Cut Assembly, Type III	2	Each		
38	6101998	Shelter Foundation, Concrete	490	Sft		
39	027767010	Concrete Sidewalk 6 inch (UDOT)	1897	Sft		
40	6301001	Curb, Type P	23	Ft		
41	6301005	Curb and Gutter, Type A	23	Ft		
42	6301011	Curb and Gutter, Type G	371	Ft		
43	6301097	Curb, Type P, Modified	35	Ft		
44	6301098	Curb and Gutter, Type G, Modified	41	Ft		
45	6301099	Concrete Curb Wall	78	Ft		
46	027767025	Concrete Curb and Gutter Type B1 (UDOT)	174	Ft		

47	8101001	Relocate Sign - New Post	9	Each		
48	8101005	Sign Post	4	Each		
49	027687050	4 inch Pavement Marking Epoxy - White Type 2 (UDOT)	239	Ft		
50	027687060	4 inch Pavement Marking Epoxy - Yellow Type 2 (UDOT)	222	Ft		
51	027687075	Pavement Message (Epoxy), Type 2 (UDOT)	19	Each		
52	8991001	Curb Painting - Red	40	Ft		
53	9999005	Install Bus Shelter	9	Each		

BID SCHEDULE A TOTAL

_____ Dollars (\$ _____)

B. MEASUREMENT AND PAYMENT PROVISIONS.

BID ITEM MEASUREMENT AND PAYMENT

GENERAL

This section provides a description of the items in the Bid Schedule of these Contract Documents. The quantities of work or material stated in unit price items of the Bid are supplied only to give an indication of the general scope of the WORK; the Owner does not expressly or by implication agree that the actual amount of work or material will correspond therewith, and reserves the right after award to increase or decrease the quantity of any unit price item of the WORK without a change in the unit price, and shall include the right to delete any Bid item in its entirety. Payment for materials and labor will be based on actual quantities furnished, installed, or constructed in accordance with the prices bid for unit price items. Lump sum items will not change to reflect actual quantities or services rendered, unless those items are completely deleted from the project.

Items listed with the (UDOT) designation are to follow the current set of UDOT Standard Drawings, Specifications, and requirements.

The Owner may terminate WORK on the project at any point if, in the Owner’s judgment, the Owner’s best interests are not served by continuation. Conditions which may lead to project termination include but are not limited to the Contractor’s inability to acquire necessary access permits. In such an event, the Contractor shall be paid for the value of WORK completed at that time, in accordance with the unit price and lump sum items listed on the Bid Schedule form.

PARK CITY BUS STOP PROGRAM – Phase 1
CP0025

ITEM 1: MOBILIZATION AND DEMOBILIZATION

APWA

Section 01 71 13

Payment for Mobilization and Demobilization will be based on completion of WORK as a lump sum unit. The lump sum price listed on the Bid Schedule form shall be full compensation for the moving in of rigs, pumps, equipment, power, labor, fuel, tools, and water conveyance structures, and incidentals to the project area necessary to do the WORK, and moving out of all such equipment, materials, tools, and incidentals and final site cleanup upon completion of the WORK. For purposes of partial payment, Mobilization will be paid 50% up front, 25% upon halfway completion of the project, and 25% at substantial completion.

ITEM 2: TRAFFIC CONTROL

APWA

Section 01 55 26

Costs associated with all materials, equipment and labor required for traffic control, including but not limited to barriers, signs, flagging, permits, coordination with local and state agencies, completion of traffic control plan, and other incidentals as required to complete the work as shown on the plans, and as specified herein. Traffic Control along State Routes must follow UDOT Standard Drawings and Specifications. 25% of bid item amount paid with first estimate. Remaining portion of bid item paid as percentage of contract completed with each subsequent estimate.

ITEM 3: SURVEY

APWA

Section 01 71 23

Costs associated with all materials, equipment and labor required for establishing survey control. Separate payment will not be made for each Bus Stop location.

ITEM 4: ROADWAY EXCAVATION

APWA

Section 31 23 16

Includes labor, equipment, and materials to complete roadway excavation as indicated on plans. Includes clearing and grubbing and/or removal of topsoil.

ITEM 5: ROADWAY EXCAVATION (PLAN QUANTITY) (UDOT)

UDOT

Section 02316

Includes labor, equipment, and materials to complete roadway excavation as indicated on plans. Includes clearing and grubbing and/or removal of topsoil. Pay item to follow the current set of UDOT Standard Drawings, Specifications, and requirements.

ITEM 6: REMOVE TREE (UDOT)

UDOT

Section 02221

Measurement for payment includes all labor, material, equipment, and incidentals. No separate payment shall be made for materials, labor, or equipment necessary for completing the work. Pay item to follow the current set of UDOT Standard Drawings, Specifications, and requirements.

ITEM 7: REMOVE DRAINAGE STRUCTURE APWA
Section 02 41 13
Measurement for payment includes all labor, material, equipment, and incidentals. No separate payment shall be made for materials, labor, or equipment necessary for completing the work.

ITEM 8: REMOVE ASPHALT PAVEMENT APWA
Section 02 41 14
Measurement for payment includes all labor, material, equipment, and incidentals. Measurement is regardless of depth and does not include limits of the new roadbed or other roads that are disturbed in performing other items of work, i.e., Roadway Excavation. No separate payment shall be made for materials, labor, or equipment necessary for completing the work. Includes saw cutting.

ITEM 9: REMOVE CONCRETE PAVEMENT APWA
Section 02 41 14
Measurement for payment includes all labor, material, equipment, and incidentals. Measurement is regardless of depth and does not include limits of the new roadbed or other roads that are disturbed in performing other items of work, i.e., Roadway Excavation. No separate payment shall be made for materials, labor, or equipment necessary for completing the work. Includes saw cutting.

ITEM 10: T-PATCH MILLING APWA
Section 32 01 16.71
Measurement for payment includes all labor, material, equipment, and incidentals. No separate payment shall be made for materials, labor, or equipment necessary for completing the work. Includes disposal of rotomill tailings.

ITEM 11: REMOVE ASPHALT PAVEMENT (UDOT) UDOT
Section 0221
Measurement for payment includes all labor, material, equipment, and incidentals. Measurement is regardless of depth and does not include limits of the new roadbed or other roads that are disturbed in performing other items of work, i.e., Roadway Excavation. No separate payment shall be made for materials, labor, or equipment necessary for completing the work. Includes sawcutting. Pay item to follow the current set of UDOT Standard Drawings, Specifications, and requirements.

ITEM 12: REMOVE SIDEWALK APWA
Section 02 41 14
Measurement for payment includes all labor, material, equipment, and incidentals. Use the area of horizontal projection to calculate the area of steps. No separate payment shall be made for materials, labor, or equipment necessary for completing the work. Includes sawcutting, removal of detectable warning surfaces, flares, and curb walls.

ITEM 13: REMOVE CURB AND GUTTER APWA
Section 02 41 14
Measurement for payment includes all labor, material, equipment and incidentals. No separate payment shall be made for materials, labor, or equipment necessary for completing the work. Includes sawcutting.

ITEM 14: RELOCATE SIGN LESS THAN 20 SQUARE FEET (UDOT) UDOT
Section 02891

Measurement for payment includes removal and disposal of existing concrete sign base, new sign base, new sign foundation, new sign post and mounting hardware, all labor, material, equipment and incidentals. No separate payment shall be made for materials, labor, or equipment necessary for completing the work. Pay item to follow the current set of UDOT Standard Drawings, Specifications, and requirements.

ITEM 15: REMOVE PAVEMENT MARKING APWA
Section 32 17 23

Measurement for payment includes all labor, material, equipment, and incidentals. No separate payment shall be made for materials, labor, or equipment necessary for completing the work.

ITEM 16: REMOVE EXISTING BUS STOP AMENITY APWA
Section 02 41 13

Measurement for payment includes all labor, material, equipment, and incidentals to remove existing bus stop bench or trashcan. No separate payment shall be made for materials, labor, or equipment necessary for completing the work. Salvage amenities back to Park City unless otherwise directed by the Engineer.

ITEM 17: REMOVE EXISTING BUS STOP SHELTER APWA
Section 02 41 13

Measurement for payment includes all labor, material, equipment, and incidentals to remove existing bus stop shelter. No separate payment shall be made for materials, labor, or equipment necessary for completing the work. Salvage amenities back to Park City unless otherwise directed by the Engineer.

ITEM 18: UNTREATED BASE COURSE APWA
Section 32 11 23

Measurement for payment includes untreated base course in final position, including all hauling, placement, and compaction and all labor, material, equipment, and incidentals. No separate payment shall be made for materials, labor, or equipment necessary for completing the work.

ITEM 19: UNTREATED BASE COURSE (UDOT) UDOT
Section 02721

Measurement for payment includes untreated base course in final position, including all hauling, placement, and compaction and all labor, material, equipment, and incidentals. No separate payment shall be made for materials, labor, or equipment necessary for completing the work. Pay item to follow the current set of UDOT Standard Drawings, Specifications, and requirements.

ITEM 20: GRANULAR BORROW APWA
Section 31 05 13

Measurement for payment includes granular borrow in final position, including all hauling, placement, and compaction and all labor, material, equipment, and incidentals. No separate payment shall be made for materials, labor, or equipment necessary for completing the work.

ITEM 21: GRANULAR BORROW (UDOT) UDOT
Section 02056

Measurement for payment includes granular borrow in final position, including all hauling, placement, and compaction and all labor, material, equipment, and incidentals. No separate payment shall be made for materials, labor, or equipment necessary for completing the work. Pay item to follow the current set of UDOT Standard Drawings, Specifications, and requirements.

ITEM 22: RELOCATE LANDSCAPING BOULDER APWA
Section 31 23 17

Measurement for payment includes all labor, material, equipment, and incidentals to remove, stockpile, and final placement of existing landscaping boulders. No separate payment shall be made for materials, labor, or equipment necessary for completing the work. Contractor to coordinate final location with owners as specified in the plans.

ITEM 23: LANDSCAPING – GRAVEL MULCH APWA
Section 32 92 00

Measurement for payment includes all labor, material, equipment, and incidentals. No separate payment shall be made for materials, labor, or equipment necessary for completing the work. Includes weed fabric. Submit aesthetics to Park City and the Engineer for approval prior to placement. Salvage and reuse existing gravel mulch where present with approval of Park City and the Engineer.

ITEM 24: LANDSCAPING – MULCH APWA
Section 32 92 00

Measurement for payment includes all labor, material, equipment, and incidentals. No separate payment shall be made for materials, labor, or equipment necessary for completing the work. Includes weed fabric. Submit aesthetics to Park City and the Engineer for approval prior to placement. Salvage and reuse existing mulch where present with approval of Park City and the Engineer.

ITEM 25: LANDSCAPING TURF APWA
Section 32 92 00

Measurement for payment includes, topsoil, turf sod, all labor, material, equipment, and incidentals. No separate payment shall be made for materials, labor, or equipment necessary for completing the work. Does not include changes to irrigation or sprinkler systems.

ITEM 26: DROUGHT TOLERANT GRASSES APWA
Section 32 92 00

Measurement for payment includes, topsoil, seeding, all labor, material, equipment, and incidentals. No separate payment shall be made for materials, labor, or equipment necessary for completing the work. Does not include changes to irrigation or sprinkler systems. Contractor to submit seed mix to Park City and the Engineer for approval prior to placement.

ITEM 27: DRAINAGE PIPE – 15 INCH, REINFORCED CONCRETE APWA
Section 33 05 02

Measurement for payment includes all labor, material, equipment, and incidentals. No separate payment shall be made for materials, labor, or equipment necessary for completing the work. Includes trenching, shoring, excavation, pipe bedding, jointing, backfill, compaction, and connection to adjacent structures.

ITEM 28: 4' STANDARD MANHOLE, 44" FRAME AND COVER APWA
Section 33 41 00

Measurement for payment includes all labor, material, equipment, and incidentals. No separate payment shall be made for materials, labor, or equipment necessary for completing the work. Includes shoring, excavation, backfill, compaction, and connection to existing and/or proposed pipes.

ITEM 29: CATCH BASIN – SINGLE GRADE APWA
Section 33 41 00

Measurement for payment includes all labor, material, equipment, and incidentals. No separate payment shall be made for materials, labor, or equipment necessary for completing the work. Includes shoring, excavation, backfill, compaction, and connection to existing and/or proposed pipes.

ITEM 30: DRAINAGE STRUCTURE COVER ADJUST APWA
Section 33 41 00

Measurement for payment includes all labor, material, equipment, and incidentals. Drainage structure to be set to new or adjusted grades. No separate payment shall be made for materials, labor, or equipment necessary for completing the work. Includes removal of existing collars, concrete, salvaging existing covers, and materials necessary to raise or lower cover. Park City Public Works to evaluate and approve installation prior to payment, no additional payment will be made for any rework needed as determined by Park City. Park City to evaluate the existing cover and provide a new cover as determined by Park City. Cost to install a new cover is included in this item.

ITEM 31: RECONSTRUCT VALVE BOX – LOWER (UDOT) UDOT
Section 01892

Measurement for payment includes all labor, material, equipment, and incidentals. Valve box to be set to new or adjusted grades. No separate payment shall be made for materials, labor, or equipment necessary for completing the work. Includes removal of existing collars, concrete, salvaging existing covers, and materials necessary to raise or lower cover. Pay item to follow the current set of UDOT Standard Drawings, Specifications, and requirements. Park City Water Department to evaluate and approve installation prior to payment, no additional payment will be made for any rework needed as determined by Park City. Park City to evaluate the existing cover and provide a new cover as determined by Park City. Cost to install a new cover is included in this item.

ITEM 32: LANDSCAPING - IRRIGATION

APWA

Section 32 84 23

Measurement for payment includes excavation, sprinkler system materials, all labor, material, equipment, and incidentals to re-establish and adjust existing irrigation at all project locations. All pipe underneath proposed asphalt or concrete shall be sleeved. No separate payment shall be made for materials, labor, or equipment necessary for completing the work. Bid Price not to exceed \$20,000.

ITEM 33: HMA – ½ INCH (UDOT)

UDOT

Section 02741

Measurement for payment Includes aggregates, asphalt binder, hydrated lime, tack coat, hauling, placement, compaction, and other additives, labor, equipment, and incidentals. No separate payment shall be made for materials, labor, or equipment necessary for completing the work. Pay item to follow the current set of UDOT Standard Drawings, Specifications, and requirements.

ITEM 34: HMA – ½ INCH BIKE/PED PATH (UDOT)

UDOT

Section 02741

Measurement for payment Includes aggregates, asphalt binder, hydrated lime, tack coat, hauling, placement, compaction, and other additives, labor, equipment, and incidentals. No separate payment shall be made for materials, labor, or equipment necessary for completing the work. Pay item to follow the current set of UDOT Standard Drawings, Specifications, and requirements.

ITEM 35: SIDEWALK, CONCRETE 6 INCH

APWA

Section 32 16 13

Measurement for payment includes concrete, placement, finishing, untreated base course, labor, equipment, and incidentals. No separate payment shall be made for materials, labor, or equipment necessary for completing the work.

ITEM 36: COLORED CONCRETE, CROSSWALK

APWA

Section 32 16 13

Measurement for payment includes concrete, placement, finishing, labor, equipment, and incidentals. No separate payment shall be made for materials, labor, or equipment necessary for completing the work. Submit aesthetics to Park City and the Engineer for approval prior to placement.

ITEM 37: CORNER CURB CUT ASSEMBLY, TYPE III

APWA

Section 32 16 14

Measurement for payment includes all labor, equipment, untreated base course, detectable warning surface, concrete, and materials necessary for a complete pedestrian access ramp. The curb cut will remain part of the curb and gutter installation.

ITEM 38: SHELTER FOUNDATION, CONCRETE

APWA

Section 32 16 13

Measurement for payment includes concrete, reinforcing steel, labor, equipment, and incidentals. No separate payment shall be made for materials, labor, or equipment necessary for completing the work. Install shelter foundation per shelter manufacturer recommendations.

ITEM 39: CONCRETE SIDEWALK 6 INCH (UDOT)

UDOT

Section 02776

Measurement for payment includes concrete, placement, finishing, untreated base course, labor, equipment, and incidentals. No separate payment shall be made for materials, labor, or equipment necessary for completing the work. Pay item to follow the current set of UDOT Standard Drawings, Specifications, and requirements.

ITEM 40: CURB, TYPE P

APWA

Section 32 16 13

Measurement for payment includes concrete, placement, finishing, untreated base course, labor, equipment, and incidentals. No separate payment shall be made for materials, labor, or equipment necessary for completing the work.

ITEM 41: CONCRETE CURB TYPE A

APWA

Section 32 16 13

Measurement for payment includes concrete, placement, finishing, untreated base course, labor, equipment, and incidentals. No separate payment shall be made for materials, labor, or equipment necessary for completing the work.

ITEM 42: CONCRETE CURB TYPE G

APWA

Section 32 16 13

Measurement for payment includes concrete, placement, finishing, untreated base course, labor, equipment, and incidentals. No separate payment shall be made for materials, labor, or equipment necessary for completing the work.

ITEM 43: CURB, TYPE P, MODIFIED

APWA

Section 32 16 13

Measurement for payment includes concrete, placement, finishing, untreated base course, labor, equipment, and incidentals. No separate payment shall be made for materials, labor, or equipment necessary for completing the work.

ITEM 44: CURB AND GUTTER, TYPE G, MODIFIED

APWA

Section 32 16 13

Measurement for payment includes concrete, placement, finishing, untreated base course, labor, equipment, and incidentals. No separate payment shall be made for materials, labor, or equipment necessary for completing the work.

ITEM 45: CONCRETE CURB WALL

APWA

Section 32 16 13

Measurement for payment includes concrete, reinforcement, placement, finishing, untreated base course, labor, equipment, and incidentals. No separate payment shall be made for materials, labor, or equipment necessary for completing the work.

ITEM 46: CONCRETE CURB AND GUTTER TYPE B1 (UDOT) UDOT
Section 02776

Measurement for payment includes concrete, placement, finishing, untreated base course, labor, equipment, and incidentals. No separate payment shall be made for materials, labor, or equipment necessary for completing the work. Pay item to follow the current set of UDOT Standard Drawings, Specifications, and requirements.

ITEM 47: RELOCATE SIGN – NEW POST APWA
Section 32 01 05

Measurement for payment includes removal and disposal of existing concrete sign base, existing signpost, new sign base, new sign foundation, new sign post, and hardware, all labor, material, equipment and incidentals. No separate payment shall be made for materials, labor, or equipment necessary for completing the work.

ITEM 48: SIGN POST APWA
Section 32 01 05

Measurement for payment includes new sign base, new sign foundation, new sign post and hardware, all labor, material, equipment and incidentals. No separate payment shall be made for materials, labor, or equipment necessary for completing the work. Sign panel to be installed by others.

ITEM 49: 4 INCH PAVEMENT MARKING EPOXY – WHITE TYPE 2 (UDOT) UDOT
Section 32 17 23

Measured for type and width shown in price schedule, measured by the foot, complete and in place, regardless of width. Includes pavement gridding. Additional payment will not be made for second application of paint. Bid price consist of roadway striping, layout, field quality control, cleaning the roadway, and incidental work to make the system complete and operational. Removal of unauthorized, smeared, or damaged markings will not be paid for. No additional money will be paid if product needs to be reinstalled due to: asphalt tracked on it by the Contractor or other vehicles if site is left unsecure or if the installation fails during the warranty period. Wet paint tracked on the pavement will be removed at no additional cost to the Owner. Pay item to follow the current set of UDOT Standard Drawings, Specifications, and requirements.

ITEM 50: 4 INCH PAVEMENT MARKING EPOXY – YELLOW TYPE 2 (UDOT) UDOT
Section 32 17 23

Measured for type and width shown in price schedule, measured by the foot, complete and in place, regardless of width. Includes pavement gridding. Additional payment will not be made for second application of paint. Bid price consist of roadway striping, layout, field quality control, cleaning the roadway, and incidental work to make the system complete and operational. Removal of unauthorized, smeared, or damaged markings will not be paid for. No additional money will be paid if product needs to be reinstalled due to: asphalt tracked on it by the Contractor or other vehicles if site is left unsecure or if the installation fails during the warranty period. Wet paint tracked on the pavement will be removed at no additional cost to the Owner. Pay item to follow the current set of UDOT Standard Drawings, Specifications, and requirements.

ITEM 51: PAVEMENT MESSAGE (EPOXY), TYPE 2 (UDOT)

UDOT

Section 32 17 23

Pavement Messages shall be Epoxy. Includes pavement grinding. Measurement for payment includes all labor, material, equipment, and incidentals. No separate payment shall be made for materials, labor, or equipment necessary for completing the work. Pay item to follow the current set of UDOT Standard Drawings, Specifications, and requirements. Measured for type shown in price schedule each message.

1. Arrow = one message
2. Crosswalk = two messages per lane and two messages per shoulder
3. Stop Line = one message per lane and one message per shoulder
4. Bicycle pavement markings
 - a. Bicycle (no rider) = one message
 - b. Sharrow (double chevron) = one message
 - c. Bicycle and Rider = one message

ITEM 52: CURB PAINTING - RED

APWA

Section 09 91 00

Measured by the foot, complete and in place, regardless of width. Contractor to paint entire face and top of curb. Additional payment will not be made for second application of paint. Removal of unauthorized, smeared, or damaged markings will not be paid for. No additional money will be paid if product needs to be reinstalled due to: asphalt tracked on it by the Contractor or other vehicles if site is left unsecure or if the installation fails during the warranty period. Wet paint tracked on the pavement will be removed at no additional cost to the Owner.

ITEM 53: INSTALL BUS SHELTER

APWA

Section 13 34 19

Measurement for payment includes all labor, material, equipment, mounting hardware, and incidentals to secure, transport, stockpile, assemble, and install bus shelters. Bus shelter components to be supplied by Park City. Assemble and install per manufacturers recommendations. No separate payment shall be made for materials, labor, or equipment necessary for completing the work. Park City will inspect and approve all installations before payment is made.

1.2 CONSTRUCTION AGREEMENT

- A. ENHANCED BUS PARK CITY BUS STOP PROGRAM – PHASE 1
CP0025**

1.3 REFERENCES

- A.** APWA Document 01 29 00: Payment Procedures.
B. Appendix B: Construction Agreement.

1.4 SCHEDULE TO BE ADDED TO THE CONSTRUCTION AGREEMENT

- A.** This document will be added to the Construction Agreement by reference.

END OF DOCUMENT

DOCUMENT 00 43 36 - PROPOSED SUBCONTRACTOR FORM

PART 1 GENERAL

1.1 BIDDER

- A. Name: _____
- B. Address: _____

- C. Telephone Number: _____

1.2 CONSTRUCTION AGREEMENT

- A. BUS PARK CITY BUS STOP PROGRAM
CP0025**

PART 2 REPORT

2.1 SUBCONTRACTOR AND SUPPLIER REPORT

- A. Failure of Bidder to specify a Subcontractor for any portion of the Work constitutes an agreement by Bidder that Bidder is fully qualified to perform that portion and that Bidder shall perform that portion. See Instructions to Bidders (Document 00 21 13, paragraph 3.4(B)) for additional information concerning the subcontractors and the nature and extent of any work that must be listed on this form.
- B. Bidder will be fully responsible to Owner for the acts and omissions of Subcontractors and Suppliers and of persons either directly or indirectly employed by them, as Bidder is for the acts and omissions of persons employed by Bidder directly.
- C. Nothing contained in the Contract Documents shall create any contractual relationship between any Subcontractor or Supplier and Owner. Bidder agrees that each subcontract with Bidder's Subcontractor will disclaim any third party or direct relationship between Owner and any Subcontractor or Supplier.
- D. The names and addresses of the Subcontractors and Suppliers who will work under the terms of the Contract Documents and the estimated dollar amount of each subcontract, as appropriate, are set forth in the following tables.

SUBCONTRACTORS		
Name	Nature and Extent of Work to be Subcontracted	Amount
1.		
2.		
3.		
Total \$ _____		
Percent of Total Contract _____%		
SUPPLIERS		
Name	Nature and Extent of Work to be Subcontracted	Amount
1.		
2.		
3.		
4.		

PART 3 EXECUTION

3.1 EFFECTIVE DATE

A. Bidder executes this Subcontractor and Supplier report and declares it to be a supplement to the Bid (Document 00 41 00) and in effect as of _____, 20__

3.2 BIDDER'S SUBSCRIPTION

A. Bidder's signature: _____

B. Please print Bidder's name here: _____

C. Title: _____

END OF DOCUMENT

DOCUMENT 00 43 37 - WORK UNDER CONTRACT REPORT

PART 1 GENERAL

1.1 BIDDER

- A. Name: _____
- B. Address: _____

- C. Telephone Number: _____

1.2 CONSTRUCTION AGREEMENT

**A. PARK CITY BUS STOP PROGRAM
CP0025**

PART 2 REPORT

2.1 STATUS OF WORK UNDER CONTRACT

- A. The completion and submission to Owner of the following table by Bidder is required within seven (7) calendar days after Engineer's request per Section 3.1 of the Instructions to Bidders (Document 00 21 13). Owner may declare Bidder non-responsive if this report is not submitted on time.
- B. The successful Bidder is required to notify Owner in writing of any new contracts awarded before the execution of the Construction Agreement.

STATUS OF WORK UNDER CONTRACT

	Description of Contract And for Whom Performed	Date of Award	Amount of Contract	Contract Completion Date	Percent Complete	Scheduled Completion Date	Dollar Amount Outstanding
1							
2							
3							
4							
5							
6							
7							
8							
9							
10							

Total of Dollar Amount Outstanding \$ _____

Contractor's Bid for this Project \$ _____

TOTAL \$ _____

C. Add supplemental sheets if necessary to account for all work under contract.

PART 3 EXECUTION

3.1 EFFECTIVE DATE

A. Bidder executes this Work Under Contract Report and declares it to be a supplement to the Bid (Document 00 41 00) and in effect as of _____, 20____.

3.2 BIDDER'S SUBSCRIPTION

A. Bidder's signature: _____

B. Please print Bidder's name here: _____

C. Title: _____

END OF DOCUMENT

DOCUMENT 00 43 38 - BIDDER STATUS REPORT

PART 1 GENERAL

1.1 BIDDER

- A. Name: _____
B. Address: _____
C. Telephone number: _____

1.2 CONSTRUCTION AGREEMENT

A. PARK CITY BUS STOP PROGRAM CP0025

PART 2 REPORT

2.1 BIDDER STATUS REPORT

A. Bidder affirms that the following information is true and correct.

1. Number of employees: _____
2. Bidder's firm is: (check all of the following that are applicable)

- Independently owned and operated.
 An affiliate of*
 A subsidiary of*
 A division of*
 A business with gross revenue in excess of \$ _____
 A business with gross revenue below \$ _____

* PARENT COMPANY:

Name: _____
Address: _____
Telephone Number: _____

PART 3 EXECUTION

3.1 EFFECTIVE DATE

A. Bidder executes this status report and declares it to be a supplement to the Bid Form (Document 00 41 00) and in effect as of _____, 20 ____.

B. BIDDER'S SUBSCRIPTION

1. Bidder's Signature: _____
2. Please print Bidder's name here: _____
3. Title: _____

END OF DOCUMENT

DOCUMENT 00 61 13 - PERFORMANCE BOND

PART 1 GENERAL

1.1 BOND

- A. Number: _____.
- B. Amount: _____
_____ dollars (\$ _____).

1.2 SURETY

- A. Name: _____
- B. Address: _____
- C. Telephone number: _____.

1.3 Contractor

- A. Name: _____
- B. Address: _____
- C. Telephone number: _____.

1.4 Owner

- A. Park City Municipal Corporation, a Utah municipal corporation, 445 Marsac Ave, Park City, Utah 84060.

1.5 CONSTRUCTION AGREEMENT

A. PARK CITY BUS STOP PROGRAM CP0025

1.6 DEFINED TERMS

- A. Terms used in this Performance Bond which are defined in Article 1.1 of the General Conditions (Document 00 72 00) in the current edition of the Manual of Standard Specifications by the Utah Chapter of the American Public Works Association will have the meanings indicated in the General Conditions.

PART 2 COVENANTS

2.1 SURETY'S AND CONTRACTOR'S RELATIONSHIP

- A. The Surety, as surety, and the Contractor, as principal, jointly and severally, bind themselves, their heirs, executors, administrators, successors, and assigns to the Owner, as obligee, for the performance of the Construction Agreement.
- B. If the Contractor performs the Construction Agreement, the Surety and the Contractor shall have no obligation under this Bond; otherwise this Bond shall remain in full force and effect.

2.2 NOTICE

- A. Notice to the Surety, the Owner, or the Contractor shall be sent by registered or certified mail, postage prepaid, by hand delivery, or by overnight delivery service for which a delivery receipt is required, to the address shown on this Bond.
- B. Notices sent as provided in Section 2.2(A) shall be effective on the date on which such notice was sent.
- C. If the time for response to any notice expires on a Saturday, Sunday, or a legal holiday in the State of Utah, the time shall be extended to the next business day.

2.3 PROCEDURE TO INVOKE SURETY'S OBLIGATION

- A.** If the Contractor fails to perform any of its obligations under the Construction Agreement, and such failure to perform has not been waived by the Owner, the Owner may notify the Contractor and the Surety, at their addresses described above, that the Contractor is in default, and may formally terminate the Contractor's right to perform its obligations under the Construction Agreement.
- B.** If the Construction Agreement is terminated, the Owner shall pay the unpaid Balance of the Contract Price to the Surety for completion of the Work in accordance with the terms of the Construction Agreement or to a contractor selected by the Surety to perform the Work in accordance with the terms of the Construction Agreement.

2.4 SURETY'S OPTIONS AT CONTRACTOR TERMINATION

- A. Surety Completes the Work:** The Surety may undertake to perform and complete the Work itself, through its agents, or through independent contractors.
- B. Surety Obtains Bids or Proposals:** The Surety may obtain bids or negotiated proposals from qualified contractors acceptable to the Owner for a contract for performance and completion of the Work.
 - 1.** Such bids or proposals shall be prepared by the Surety for execution by the Owner and the completion contractor selected.
 - 2.** The Surety shall secure the contract with performance and payment bonds executed by a qualified surety equivalent to this Bond and the payment bond (Document 00 61 14).
 - 3.** The Surety shall pay to the Owner the amount of damages as described in Section 2.6 in excess of the balance of the Contract Price incurred by the Owner resulting from the Contractor's default.
- C. Surety to Pay Owner:** The Surety may determine the amount, not to exceed the amount of this Bond specified in Section 1.1(B), for which the Surety believes it may be liable to pay, and tender payment therefore to the Owner. The Owner has sole discretion to accept payment.

2.5 PROCEDURE FOR OWNER TO DECLARE SURETY IN DEFAULT

- A.** The Owner may declare the Surety to be in default pursuant to the following procedures:
 - 1.** The Owner shall issue an additional written notice to the Surety, after declaring the Contractor in default as provided in Section 2.3, demanding that the Surety perform its obligations under this Bond; and
 - 2.** The Surety shall respond to the Owner within fifteen (15) days after receipt of the Owner's additional notice, either denying the claim or accepting liability and exercising its options under Section 2.4.
- B.** If the Owner declines to accept the payment tendered by the Surety pursuant to Section 2.4(C), or if the Surety has denied the claim in whole or in part, the Owner, without further notice, may pursue any remedies available to the Owner.

2.6 SURETY'S OBLIGATIONS

- A.** After the Owner has terminated the Contractor's right to complete its obligations under the Construction Agreement, and if the Surety elects to complete the Work under the Construction Agreement as provided in Section 2.4, then the responsibilities of the Surety to the Owner shall not be greater than those of the Contractor under the Construction Agreement, and the responsibilities of the Owner to the Surety shall not be greater than those of the Owner under the Construction Agreement.
- B.** To the limit of the amount of this Bond, but subject to a commitment by the Owner to pay all valid and proper payments made to or on behalf of the Contractor under the Construction Agreement, the Surety is obligated, without duplication, for:
 - 1.** the responsibilities of the Contractor for correction of Defective Work and completion of the Work under the Construction Agreement;
 - 2.** any additional legal, design professional, and delay costs resulting from the Contractor's default, and resulting from the actions or failure to act of the Surety under Section 2.4; and
 - 3.** liquidated damages that are or may become due for any reason.

2.7 UNRELATED OBLIGATIONS OF THE CONTRACTOR

- A.** The Surety shall not be liable to the Owner for obligations of the Contractor that are unrelated to the Construction Agreement, and the balance of the Contract Price shall not be reduced or changed on account of any such unrelated obligations.
- B.** No right of action shall accrue on this Bond to any person or entity other than the Owner or its heirs, executors, administrators, or successors.

2.8 SURETY WAIVES NOTICE OF ANY CHANGE

- A.** Surety hereby waives notice of any change, including changes of Contract Time, Contract Price, and scope of Work, to the Construction Agreement or to related subcontracts, purchase orders, and other obligations.

2.9 VENUE

- A.** Any suit or action commenced by the Owner under this Bond shall be in a court of competent jurisdiction in Summit County, Utah.

PART 3 EXECUTION

3.1 EFFECTIVE DATE

A. The Surety and the Contractor executed this Bond and declared it to be in effect as of the _____ day of _____, 20__.

3.2 CONTRACTOR'S SUBSCRIPTION AND ACKNOWLEDGMENT

A. Name of organization: _____

B. Type of organization: _____

(corporation, partnership, limited liability company, individual, etc.)

C. Contractor's signature: _____

D. Print name here: _____

E. Title: _____

F. Business Entity Acknowledgement:

STATE OF UTAH _____)

: ss.

COUNTY OF _____)

The foregoing performance bond was acknowledged before me this _____ day of _____, 20__, by _____, the
[Name of signer]
_____ of _____, a _____
[Title of signer] [Name of entity] [State]

[State where organized and type of entity]

NOTARY PUBLIC, residing in

G. Individual Acknowledgement:

STATE OF UTAH _____)

: ss.

COUNTY OF _____)

The foregoing performance bond was acknowledged before me this _____ day of _____, 20____ by _____, an individual.

NOTARY PUBLIC, residing in

PART 4 Signature Authority

4.1 At the request of Owner, Contractor shall submit to Owner evidence satisfactory to Owner that shows that the person executing this Bond has the required authority to execute this Bond. For a corporation such evidence will be in the bylaws or a resolution of the board of directors. For a limited liability company such evidence will be in the operating agreement.

4.2 SURETY'S SUBSCRIPTION AND ACKNOWLEDGMENT

A. Attach evidence of Surety's corporate authority to sign.

B. Surety's signature: _____

C. Please print name here: _____

D. Title: _____

E. Acknowledgment:

STATE OF UTAH _____)

:

COUNTY OF _____)

The foregoing performance bond was acknowledged before me this ___ day of _____, 20__ by _____, the
(Name of signee)

_____ of _____,
(Title of signee) (Name of entity)

a _____.
(State where organized and type of entity)

NOTARY PUBLIC, residing in:

My Commission Expires:

END OF DOCUMENT

DOCUMENT 00 61 14 - PAYMENT BOND

PART 1 GENERAL

1.1 BOND

- A. Number: _____.
- B. Amount: _____ dollars (\$ _____).

1.2 SURETY

- A. Name: _____
- B. Address: _____

- C. Telephone number: _____

1.3 Contractor

- A. Name: _____
- B. Address: _____

- C. Telephone number: _____.

1.4 Owner

- A. Park City Municipal Corporation (“PCMC”), a Utah municipal corporation, 445 Marsac Ave, Park City, Utah 84060

1.5 CONSTRUCTION AGREEMENT

- A. **PARK CITY BUS STOP PROGRAM – PHASE 1 CP0025**

1.6 DEFINED TERMS

- A. Terms used in this Payment Bond that are defined in Article 1.1 of the General Conditions (Document 00 72 00) in the current edition of the Manual of Standard Specifications by the Utah Chapter of the American Public Works Association will have the meanings indicated in the General Conditions.

PART 2 COVENANTS

2.1 SURETY's AND CONTRACTOR's RELATIONSHIP

- A. The Surety as surety, and the Contractor, as principal, jointly and severally, bind themselves, their heirs, executors, administrators, successors, and assigns to the Owner, as obligee, to pay for labor, materials, and equipment furnished for use in the performance of the Construction Agreement.
- B. If the Contractor makes payment for all labor, materials, and equipment furnished for use in the performance of the Construction Agreement, the Surety and the Contractor shall have no obligation under this Bond; otherwise this Bond shall remain in full force and effect.

2.2 NOTICE

- A. Notice to the Surety, the Owner, or the Contractor shall be sent by registered or certified mail, postage prepaid, by hand delivery, or by overnight delivery service for which a delivery receipt is required, to the address shown on this Bond.

- B. Notices sent as provided in Section 2.2(A) shall be effective on the date on which such notice was sent.
- C. If any notice requires a period of less than seven (7) days for response, the notice shall be sent by overnight delivery.
- D. If the time for response to any notice expires on a Saturday, Sunday, or a legal holiday in the State of Utah, the time shall be extended to the next business day.

2.3 CONDITIONS OF SURETY'S LIABILITY

- A. With respect to the Owner, this Bond shall be null and void if the Contractor promptly takes the following actions:
 - 1. makes payment, directly or indirectly, for all sums due Claimants; and
 - 2. defends, indemnifies, and saves harmless the Owner from all claims, demands, Liens, or suits by any person or entity who furnished labor, materials, or equipment for use in the performance of the Work, provided the Owner has tendered defense of such claims, demands, Liens, or suits to the Contractor and the Surety.

2.4 PROCEDURE TO INVOKE SURETY'S OBLIGATION

- A. **Concerning Claimants who have a Direct Contract with the Contractor:** The Surety shall have no obligation to Claimants under this Bond who are employed by or have a direct contract with the Contractor until such Claimants have given notice to the Surety at the address shown on this Bond and have sent a copy, or notice thereof, to the Owner, stating that a claim is being made under this Bond and, with substantial accuracy, stating the amount of the claim.
- B. **Concerning a Claimant who does not have a Direct Contract with the Contractor:** The Surety shall have no obligation to a Claimant under this Bond who does not have a direct contract with the Contractor until such Claimant takes the following actions.
 - 1. The Claimant furnishes written notice to the Contractor and sends a copy, or notice thereof, to the Owner, within ninety (90) days after having last performed labor or last furnished materials or equipment included in the claim stating, with substantial accuracy, the amount of the claim and the name of the party to whom the materials were furnished or supplied or for whom the labor was done or performed;
 - 2. The Claimant either receives a rejection in whole or in part from the Contractor, or does not receive within fifteen (15) days after furnishing the above notice any communication from the Contractor by which the Contractor indicates that the claim will be paid directly or indirectly; and
 - 3. Not having been paid within the above fifteen (15) days, the Claimant sends a written notice to the Surety at the address described on this Bond and sends a copy, or notice thereof, to the Owner stating that a claim is being made under this Bond and enclosing a copy of the previous written notice furnished to the Contractor.

2.5 SURETY'S OPTION TO SETTLE CLAIMS

- A. When the Claimant has satisfied the conditions of Section 2.4, the Surety shall promptly and at the Surety's expense take the following actions:
 - 1. Send an answer to the Claimant, with a copy to the Owner, within sixty (60) days after receipt of the claim, stating the amounts that are undisputed and the basis for challenging any amounts that are disputed; and
 - 2. Pay or arrange for payment of any undisputed amounts.

2.6 SURETY'S OBLIGATION

- A. The Surety's total obligation under this Bond shall not exceed the amount of this Bond, and the amount of this Bond shall be reduced in the amount of any payments made in good faith by the Surety.

2.7 UNRELATED OBLIGATIONS OF THE CONTRACTOR

- A. The Surety and the Owner shall not be liable to Claimants or others for obligations of the Contractor that are unrelated to the Construction Agreement.
- B. The Owner shall not be liable for payment of any damages, costs, or expenses of any Claimant under this Bond, and shall have under this Bond no obligation to make payments to, give notices on behalf of, or otherwise have obligations to Claimants under this Bond.

2.8 SURETY WAIVES NOTICE OF ANY CHANGE

- A. Surety hereby waives notice of any change to the Construction Agreement including changes of Contract Time, Contract Price, and scope of Work, or to related subcontracts, purchase orders, or other obligations.

2.9 VENUE

- A. Any suit or action commenced by a Claimant under this Bond shall be in a court of competent jurisdiction in Summit County, Utah.

2.10 COPIES OF THIS BOND

- A. Upon request by any person or entity appearing to be a potential beneficiary of this Bond, the Contractor or the Owner shall promptly furnish a copy of this Bond or shall permit a copy to be made.

PART 3 EXECUTION

3.1 EFFECTIVE DATE

- A. The Surety and the Contractor executed this Bond and declared it to be in effect as of the _____ day of _____, 2024.

3.2 CONTRACTOR'S SUBSCRIPTION AND ACKNOWLEDGMENT

- A. Name of organization: _____
- B. Type of organization: _____
(corporation, partnership, limited liability company, individual, etc.)
- C. Contractor's signature: _____
- D. Please print name here: _____
- E. Title: _____

F. Business Entity Acknowledgement:

STATE OF UTAH _____)

: ss.

COUNTY OF _____)

The foregoing payment bond was acknowledged before me this _____ day of _____, 20____, by _____, the
[Name of signer]
_____ of _____, a _____
[Title of signer] [Name of entity] [State]

[State where organized and type of entity]

NOTARY PUBLIC, residing in

PART 4 INDIVIDUAL ACKNOWLEDGEMENT:

STATE OF UTAH _____)

: ss.

COUNTY OF _____)

The foregoing payment bond was acknowledged before me this _____ day of _____, 20____ by _____,
an individual.

NOTARY PUBLIC, residing in

My Commission Expires

PART 5 SIGNATURE AUTHORITY

5.1 At the request of Owner, Contractor shall submit to Owner evidence satisfactory to Owner that shows that the person executing this Bond has the required authority to execute this Bond. For a corporation such evidence will be in the bylaws or a resolution of the board of directors. For a limited liability company such evidence will be in the operating agreement.

5.2 SURETY'S SUBSCRIPTION AND ACKNOWLEDGMENT

A. Attach evidence of Surety's corporate authority to sign.

B. Surety's signature: _____

C. Print name here: _____

D. Title: _____

E. Acknowledgment:

STATE OF UTAH)

:

COUNTY OF _____)

The foregoing payment bond was acknowledged before me this __ day of _____

_____, 20__ by _____, the
(Name of signee)

_____ of _____,
(Title of signee) (Name of entity)

a _____.
(State where organized and type of entity)

NOTARY PUBLIC, residing in:

My Commission Expires:

END OF DOCUMENT

DOCUMENT 00 62 11 - SUBMITTAL TRANSMITTAL FORM

PART 1 GENERAL

1.1 SUMMARY

- A. Form is self-transmittal. Letter of transmittal is not required.
- B. Submittals requiring expeditious handling must be submitted individually on Submittal Transmittal Form.
- C. Engineer's review of submittals does not release or relieve Contractor from complying with all requirements of the Contract Documents.

1.2 ENGINEER'S STAMP

- A. Form of the Engineer's stamp is as follows:

<u>SUBMITTAL REVIEW</u>	
<input type="checkbox"/> NO EXCEPTIONS TAKEN	<input type="checkbox"/> REJECTED
<input type="checkbox"/> MAKE CORRECTIONS NOTED	<input type="checkbox"/> RESUBMIT
<input type="checkbox"/> SUBMIT SPECIFIED ITEM	<input type="checkbox"/> DO NOT RESUBMIT
<p>This review is for general conformance with the design concepts of the Work and general compliance with the Contract Documents and does not constitute an approval or variance. Corrections or comments, or the failure to make them, on this review does not relieve the Contractor from full contract compliance.</p> <p>The Contractor is responsible for compliance with all contract provisions, dimensions, sizes, capacities, fabrication and construction techniques, installation, coordinating work with others, and performing the Work in a safe and satisfactory manner.</p> <p>Date: _____ By: _____</p> <p style="text-align: center;">PARK CITY ENGINEERING</p>	

- B. Meaning of Engineer's stamp:

1. No Exceptions Taken: Submittals have been reviewed and no corrections were noted.
2. Make Corrections Noted: Submittals that have only minor discrepancies. Resubmission will not be required unless the stamp is marked "Resubmit".
3. Submit Specified Item: Submittals that are incomplete or require more than minor corrections will be annotated to indicate necessary corrections. Resubmit the part of the submittal showing the corrections.
4. Rejected: Submittals that are fundamentally in error, cover wrong equipment or construction, or require extensive corrections.
5. Resubmit: Submittals that require resubmission. Make corrections required, note any changes by dating the revisions to correspond with the change require date, and resubmit the corrected material.
6. Do Not Resubmit: Submittals that are not necessary to resubmit.

SUBMITTAL TRANSMITTAL FORM	DATE	<input type="checkbox"/> NEW SUBMITTAL <input type="checkbox"/> RESUBMITTAL
-----------------------------------	------	--

Section I	REQUEST FOR APPROVAL OF THE FOLLOWING ITEMS (This section will be initiated by the Contractor)
------------------	--

TO	FROM	TRANSMITTAL No.
		PREVIOUS TRANSMITTAL No.

SPECIFICATION SECTION NUMBER (See instructions)	CONTRACT TITLE	CONTRACT No.
---	----------------	--------------

SUBMITTAL ITEM No.	DESCRIPTION OF ITEM SUBMITTED (Type, size, model number, etc.)	SAMPLE OR CERTIFICATE (See instructions)	NO. OF COPIES	CONTRACT REFERENCE DOCUMENT		VARIATION (See instructions)	Engineer REVIEW CODE (See instructions)
				SPEC. PARA. No.	DRAWING SHEET No.		
a.	b.	c.	d.	e.	f.	g.	h.

REMARKS	I certify that the above submitted items have been reviewed in detail and are correct and conform with the contract Drawings and specifications except as otherwise noted. _____ NAME AND SIGNATURE OF CONTRACTOR
----------------	---

Section II	Owner'S ACTION This section will be completed by the Engineer)
-------------------	--

ENCLOSURES RETURNED (List by Item No.)	SIGNATURE OF REVIEWING AGENT	DATE
--	------------------------------	------

SUBMITTAL TRANSMITTAL FORM	DATE	<input type="checkbox"/> NEW SUBMITTAL <input type="checkbox"/> RESUBMITTAL
-----------------------------------	------	--

Section I	REQUEST FOR APPROVAL OF THE FOLLOWING ITEMS (This section will be initiated by the Contractor)
------------------	--

TO	FROM	TRANSMITTAL No.
		PREVIOUS TRANSMITTAL No.

SPECIFICATION SECTION NUMBER (See instructions)	CONTRACT TITLE	CONTRACT No.
---	----------------	--------------

SUBMITTAL ITEM No. a.	DESCRIPTION OF ITEM SUBMITTED (Type, size, model number, etc.) b.	SAMPLE OR CERTIFICATE (See instructions) c.	NO. OF COPIES d.	CONTRACT REFERENCE DOCUMENT		VARIATION (See instructions) g.	Engineer REVIEW CODE (See instructions) h.
				SPEC. PARA. No. e.	DRAWING SHEET No. f.		

FORM 00 62 11.1 (Read Instructions on the reverse side prior to initiating this form)

INSTRUCTIONS

1. TRANSMITTAL No: Number each transmittal consecutively in the space entitled “Transmittal No.”. This number will identify each submittal.
2. PREVIOUS TRANSMITTAL No: Mark the box for re-submittal and insert the transmittal number of last submission as well as the new submittal number in the spaces provided. Each re-submittal will become a new transmittal.
3. SPECIFICATION SECTION NUMBER: Cover only one specification section with each transmittal.
4. Column “a”: For each entry on this form, the “SUBMITTAL ITEM No.” will be the same SUBMITTAL ITEM No. indicated on the Submittal Register (Form 01 33 00).
5. Column “c”: When a sample of material or Manufacturer’s Certificate of Compliance is transmitted, indicate “Sample” or “Certificate”.
6. Column “g”: Contractor will place a check mark in the “Variation” column when a submittal is not in accordance with the plans and specifications – also, a written statement to that effect shall be included in the space provided for “Remarks” or on a separate page.
7. Column “h” For each item reviewed, Engineer shall assign action codes as follows:

- A. No Exceptions Taken.
- B. Make Corrections Noted. Re-submission not required.
- C. Submit Specified Item.
- D. Rejected.
- E. Re-submit
- F. Do Not Re-submit. Receipt acknowledged.
- G. Will be returned by separate correspondence.
- H. Other (Specify).

END OF SECTION

DOCUMENT 00 62 16 - CERTIFICATE OF INSURANCE

PART 1 GENERAL

1.1 PROCEDURE

- A. For filing purposes, add Certificates of Insurance to the Contract Documents following this page.

END OF DOCUMENT

DOCUMENT 00 73 10 - MODIFICATIONS TO THE GENERAL CONDITIONS
(Supplementary Conditions)

This document changes provisions specified in the General Conditions (Document 00 72 00) in the Manual of Standard Specifications published by the Utah Chapter of the American Public Works Association.

Add the following paragraphs to Article 2.2

2.2 COPIES OF DOCUMENTS

- B. Owner shall not furnish to Contractor published Contract Documents that include the current edition of the Manual of Standard Plans and the Manual of Standard Specifications. The Contractor shall purchase such documents separately.
- C. Copies of all Contract Documents including the current edition of the Manual of Standard Plans and the Manual of Standard Specifications shall be provided on site by the Contractor.

Modify paragraph 2.5(C)

2.5 BEFORE STARTING CONSTRUCTION

- C. Field Office: An on-site field office is not required; however, Contractor shall provide and maintain a telephone in the field during performance of the Work such that Engineer may always contact Contractor for transmittal of Plans and instructions and for dissemination of project information.

Modify Article 5.1

PART 5 BONDS AND INSURANCE

5.1 PERFORMANCE, PAYMENT AND OTHER BONDS

- A. Before Owner executes the Agreement, Contractor shall file with Owner a good and sufficient Performance Bond (using Owner's Document 00 61 13) and a Payment Bond (using Owner's Document 00 61 14), each in the sum of not less than one hundred percent (100%) of the Contract Price.
- B. The Bonds shall be executed by Contractor and issued by a company duly and regularly authorized to do a general surety business in the State of Utah and either (i) named in the current U.S. Treasury Department's listing of approved sureties (Department Circular 570) (as amended), or (ii) with a current "A-" rating and a financial size category rating of at least a "VII" or better in A.M. Best Co., Inc.'s Best Insurance Reports, Property and Casualty Edition.
- C. The Performance Bond shall guarantee the faithful performance of the Construction Agreement by Contractor and the Payment Bond shall guarantee the payment of labor and materials. The Bonds shall inure by their terms to the benefit of Owner. Neither this nor any other provision requiring a Performance Bond shall be construed to create any rights in any third party Claimant as against Owner for performance of the Work under the Construction Agreement.

- D. If the surety on any Bond furnished by Contractor is subject to any proceeding under the Bankruptcy Code (Title 11, United States Code) or becomes insolvent or its right to do business is terminated in the State of Utah or it ceases to meet the requirements of this Article, Contractor shall, within fifteen (15) days thereafter, substitute another Bond and surety, both of which must be acceptable to Owner.

Add the following paragraphs to Article 6.7

6.7 PERMITS

- H. Park City Permits: In addition to any other permits required for the Work, Contractor shall obtain permits from Park City Municipal Corporation for Work on the Project. Contractor shall be responsible for submitting plans, scheduling inspections and paying all costs incidental to such actions as required for any permit required by Park City Municipal Corporation.
- I. Other Permits: All other permit fees required by Summit County, the State of Utah, the United States of America, and any of their agencies, or by any private utility companies, shall be paid for and obtained by Contractor and included in Contractor's Bid. The following list is not exclusive and does not relieve Contractor of the responsibility of obtaining all permits:
1. UDOT Region 2: Digging permit in a UDOT roadway right of way.
 2. Private Property Owner Permit: Written permission to use private water.
 3. Private Property Owner Permit: Written permission to store product, equipment, materials, and supplies outside of the Work site boundaries.
 4. General Permit for Storm Water Discharge (Sites greater than 1 acres): From the State of Utah, Department of Environmental Quality, Division of Water Quality.
 5. Flood Control Permit: From Summit County, Department of Public Works.
 6. Monument Permit: From Summit County Surveyor

Modify paragraph 13.6(A)

PART 13

13.6 CORRECTION OR REMOVAL OF DEFECTIVE WORK BY CONTRACTOR

- A. In addition to Contractor's obligations under Article 6.16, if required by Engineer, Contractor shall promptly, as directed, either correct all Defective Work, whether or not fabricated, installed, or completed, or, if the Work has been rejected by Engineer, remove it from the site and replace it with non-Defective Work. No rejected material, the defects of which have been subsequently corrected, shall be used in the Work unless approval in writing has been given by Engineer. Contractor shall bear all direct, indirect, and consequential costs of such correction or removal (including but not limited to fees and charges of Owner, engineers, architects, and other professionals) made necessary thereby.

Modify paragraph 13.7(A)

13.7 CORRECTION PERIOD

- A. In addition to Contractor's obligations under Article 6.16, if any portion of the Work is found to be defective within one (1) year after the date of Substantial Completion, Contractor shall correct it or replace it with non-Defective Work. The one (1) year correction period may be superseded by such longer period of time as prescribed in the Contract Documents or by special guaranteed terms required by the Contract Documents.

Add the following paragraph to Article 13.7

13.7 CORRECTION PERIOD

- E. Nothing contained in this Article 13.7 shall be construed to establish a period of limitation with respect to other obligations Contractor has under the Contract Documents, including Article 6.16. Establishment of the one (1) year period for correction of Work as described in this Article 13.7 relates only to the specific obligation of Contractor to correct the Work, and has no relationship to the time within which the obligation to comply with the Contract Documents may be enforced, nor the time within which proceedings may be commenced to establish Contractor's liability with respect to Contractor's obligations other than specifically to correct the Work. Such times include the applicable statute of limitations or statute of repose, which may be longer than one year.

Add the following Articles to Part 16

PART 16 DISPUTE RESOLUTION

16.2 GENERAL

- A. Unless a decision is held by an appropriate court of law to have been procured by fraud or to be arbitrary and capricious or so grossly erroneous as necessarily to imply bad faith, any factual decision made under this dispute resolution procedure shall be final and binding in any suit or action arising under the Construction Agreement, including any actions by Contractor or others against Owner or any of Owner's agents, consultants, or employees.
- B. Compliance by Contractor with provisions of this Part shall be a condition precedent to any legal action by Contractor or any of Contractor's Subcontractors and Suppliers against Owner or any of Owner's agents, consultants, or employees.
- C. The provisions of this Part shall not preclude or limit judicial review of issues of law.
- D. Ambiguities in or between Contract Documents shall be construed in favor of the Owner.

16.3 DISPUTES NOT RELATED TO THE GUARANTEE OF THE WORK

- A. Any dispute arising under the Construction Agreement concerning a question of fact, not related to the guarantee of the Work (Article 13.1 of the General Conditions (Document 00 72 00)), that is not disposed of by contract Modification shall be decided pursuant to the following procedure.
 - 1. Any decision by Engineer interpreting the requirements of the Contract Documents may be appealed in writing to the Engineer. The Engineer's decision, regarding that appeal shall be reduced to writing and a copy shall be mailed or otherwise furnished

to Contractor within ten (10) days. The decision of Engineer shall be final and conclusive unless, within thirty (30) days after the date of receipt of such copy, Contractor mails a written appeal to Owner's Committee.

2. Owner and Contractor shall each have the opportunity to fully present its case to the Owner's Committee before the Owner's Committee's deliberation. The Owner's Committee may request any other materials or written memoranda necessary to consider the issue, and may schedule other proceedings as necessary.
3. The decision of the Owner's Committee shall be rendered in writing within fifteen (15) days after the Owner's Committee's final hearing of the issue and receipt of any supplemental material requested by the Owner's Committee. The decision shall be mailed or otherwise delivered to Contractor.
4. The decision of the Owner's Committee shall be the final binding interpretation of the facts that are the subject of the appeal.

16.4 DISPUTES RELATED TO THE GUARANTEE

- A. Except as otherwise provided by contract Modification, any dispute concerning a question of fact involving or arising out of the guarantee required by the Contract Documents (Article 13.1 of the General Conditions (Document 00 72 00)), that is not disposed of by contract Modification, shall be decided pursuant to the provisions of Paragraph 16.3 above, except that the initial factual decision shall be issued in writing by the Engineer.
- B. Any appeal therefrom shall be made within fifteen (15) days directly to the Dispute Committee where such disputes shall be governed by provisions in sub-paragraphs 3 to 5 in paragraph 16.3(A) above.

16.5 WORK DURING APPEAL

- A. Notwithstanding the pendency of any protest or appeal provided above, Contractor shall, if so ordered by Engineer, proceed with the Work under the Contract Documents according to Engineer's direction and according to the decision on any appeal. The existence of a claim or protest shall not excuse Contractor from the requirements of the Contract Documents, including, but not limited to, the Contract Time.

16.6 APPEALS OF TERMINATION OR SUSPENSION

- A. Any decision of Owner to terminate or suspend the Work shall not be subject to the provisions of this Part.

END OF DOCUMENT

DOCUMENT 00 73 15 - MODIFICATIONS TO APWA AND CITY STANDARD PLANS
(Supplementary Conditions)

PART 1 GENERAL

1.1 DOCUMENT INCLUDES

- A. This Document specifies changes to the Park City Supplemental Standard Plans and Specifications (available at: <https://www.parkcity.org/departments/engineering-division>) and the Standards and Specifications from the Utah Chapter of the American Public Works Association. Contractor is to apply the appropriate modification to the appropriate Standard Plan.

1.2 CHANGES

- A. Modify the standard plans as follows.

Table 1 – WATER

APWA Standard Plan No.	Description	Modification

Table 2 - SANITARY SEWER

Standard Plan No.	Description	Modification

Table 3 - STORM DRAIN

Standard Plan No.	Description	Modification

Table 4 - ROADWAY

Standard Plan No.	Description	Modification

PART 2 PRODUCT Not Used

PART 3 EXECUTION Not Used

END OF DOCUMENT

DOCUMENT 00 91 13 - ADDENDA

PART 1 GENERAL

1.1 PROCEDURE

- A. For filing purposes, add Addenda and Modifications to the Contract Documents following this page.

END OF DOCUMENT

SPECIAL PROVISIONS

DOCUMENT 13 34 19 – METAL BUILDING

Add the following Section 3.8

3.8 RECEIVING AND STORAGE OF BUS STOP SHELTERS

The Owner will coordinate the manufacturing and delivery of bus stop shelters for installation by the Contractor as part of this project. Shelters will arrive to at the designated laydown yard based on the delivery schedule provided by the Manufacturers and Owner. Shelters will arrive in crates with like pieces along with installation guidelines, shop drawings, and packing lists provided by the Manufacturer. Installation guidelines are provided here for the Contractor's use:

INSERT LINK FOR INSTALLATION VIDEO OR ADJUST LANGUAGE FOR INSTALLATION INSTRUCTIONS.

Upon arrival, the Contractor shall inspect and verify all contents and coordinate with Owner within 48 hours of delivery to discuss any components missing or damaged during delivery. Components missing or damaged during delivery coordinated during this 48 hour verification time period will be replaced or obtained by Owner at no additional cost to the Contractor and delivered to the site as schedule allows. After the 48 hour verification time period, all components, hardware, packing materials, and contents on site become the sole responsibility of the contractor, including but not limited to security, storage, protection from weather, transport to installation location, disposal of packing materials, assembly, and installation of shelters per the Manufacturer's recommendations. No additional payment will be made for materials or pieces lost, stolen, vandalized, or in any way damaged after the 48 hour verification time period or prior to final acceptance.

Appendix B

CONSTRUCTION AGREEMENT

This Construction Agreement (“**Agreement**”) is between PARK CITY MUNICIPAL CORPORATION, a Utah municipal corporation (“**PCMC**”), and _____, a _____ (insert state of incorporation) _____ (insert either “corporation” or “limited liability company”) (“**Contractor**”).

PURPOSE: For the project known as the (project name) (“**Project**”), which consists of (brief description of work and address).

The parties therefore agree as follows:

SECTION 1. SCOPE OF WORK. Contractor shall furnish all labor, materials and equipment to complete the Project, consisting of the work described in the Information for Bidders as the Basic Bid, as specifically set out in the contract specifications, which is made a part hereof by reference.

The Project will be bound by the specifications referenced herein, according to the Advertisement for Bid, the Information for Bidders, the General Project Requirements and Specifications provided by PCMC, the Bid of the Contractor, Bid Bond, Drawings, Notice of Award and Notice to Proceed, (collectively referred to as the “Contract Documents”), all of which are incorporated herein by reference and on file in the Engineering Department. To the extent that this Agreement conflicts in any way with a proposed form agreement which may have been submitted as part of the bid specifications, this Agreement shall control.

If any of the work performed by Contractor in any phase of the Project does not meet PCMC standards as outlined in the bid documents and specifications, then Contractor shall immediately repair or correct the work at no additional cost to PCMC.

A. Subcontractors. No part of this Agreement shall be subcontracted by the Contractor without prior written approval by PCMC through the Project Manager/Engineer. The Contractor shall be fully responsible to PCMC for the acts and omissions of its subcontractors and of persons either directly or indirectly employed by them as it is for the acts and omissions of persons directly employed by it.

If written approval is granted to subcontract a part of this Agreement, the Contractor shall require each subcontractor that physically performs services within Utah to submit an affidavit to the Contractor stating that the subcontractor has used E-Verify, or an equivalent program, to verify the employment status of each new employee.

The Contractor shall, within 10 days of submittal of request for final payment, include an affidavit showing satisfactory evidence that all claims of subcontractors, laborers and material men who supplied services or materials to the Project have been fully paid, discharged, or waived. The Contractor shall submit lien waivers for each pay release.

If PCMC reasonably believes that Contractor has failed to pay Subcontractors, materialmen, or laborers for work on the Project within a reasonable time of when payment is due, then PCMC may, after having notified the Contractor, either pay unpaid bills or withhold from the release of Contractor's payment bond for this Project, a sum of money deemed reasonably sufficient to pay any and all such lawful claims until satisfactory evidence is furnished that all liabilities have been fully discharged and a 10% fee for administering such claims.

B. Standards of Workmanship. Contractor shall demonstrate workmanship equal to or better than current industry standards for this Project. Where PCMC specifications exist, (for example, asphalt, concrete, irrigation, sprinkling system and landscaping), they shall provide the benchmark for determination of acceptability.

C. Inspection and Testing. All materials and equipment used in the construction shall be subject to inspection by the Project Manager/Engineer. If laws, ordinances, rules or regulations of any public authority having jurisdiction require any work to specifically be inspected, tested, or approved by someone other than Project Manager/Engineer, the Contractor shall give the Project Manager/Engineer timely notice of readiness. Inspections, tests or approvals by PCMC or appropriate authorities will not relieve the Contractor from obligations to perform the work in accordance with the requirements of the Contract Documents and/or provisions. The Project Manager/Engineer and other designated persons will at all times have access to the work. All work shall ultimately be inspected for final acceptance by the Project Manager/Engineer within a reasonable time upon receipt of notice from the Contractor that work is complete and ready for final inspection.

During construction, the work will be inspected and observed by the Project Manager/Engineer or his designated representative. All work that is deficient or does not meet specifications shall be removed and replaced with proper material at Contractor's expense.

D. Warranty. Contractor warrants that all materials and supplies used in the construction of the Project shall be new, except as otherwise agreed to in writing by PCMC's Representative. All materials, equipment, parts and labor and any necessary corrections to the Project shall be guaranteed for a period of at least one year following the date of substantial completion of the Project under the terms of the performance bond or as provided in the project specifications and construction documents, whichever is longer.

E. Adopted Codes. All work shall be completed at a minimum in accordance with all building, electric and energy codes adopted by PCMC.

SECTION 2. PERFORMANCE AND PAYMENT BONDS. Contractor shall furnish to PCMC payment and performance bonds satisfactory to PCMC guaranteeing Contractor's payment and performance, in the amount, for each separately, of 100% of the Agreement Amount.

SECTION 3. INSURANCE. At its own cost and expense, Contractor shall maintain the following mandatory insurance coverage to protect against claims for injuries to persons or property damage that may arise from or relate to the performance of this Agreement by Contractor, its agents, representatives, employees, or Subcontractors for the entire duration of this Agreement or for such longer period of time as set forth below. Prior to commencing any work, Contractor shall furnish a certificate of insurance as evidence of the requisite coverage. The certificate of insurance must include endorsements for additional insured, waiver of subrogation, primary and non-contributory status, and completed operations.

A. Commercial General Liability Insurance. Contractor shall maintain commercial general liability insurance on a primary and non-contributory basis in comparison to all other insurance, including PCMC's own policies of insurance, for all claims against PCMC. The policy must be written on an occurrence basis with limits not less than \$2,000,000 per occurrence and \$3,000,000 aggregate for personal injury and property damage. Upon request of PCMC, Contractor must increase the policy limits to at least the amount of the limitation of judgments described in Utah Code § 63G-7-604, the Governmental Immunity Act of Utah (or successor provision), as calculated by the state risk manager every two years and stated in Utah Admin. Code R37-4-3 (or successor provision).

B. Automobile Liability Coverage. Contractor shall maintain automobile liability insurance with a combined single limit of not less than \$2,000,000 per accident for bodily injury and property damage arising out of the ownership, maintenance, and use of owned, hired, and non-owned motor vehicles. This policy must not contain any exclusion or limitation with respect to loading or unloading of a covered vehicle.

C. Workers' Compensation Insurance and Employer's Liability. Contractor shall maintain workers' compensation insurance with limits not less than the amount required by statute, and employer's liability insurance limits of at least \$1,000,000 each accident, \$1,000,000 for bodily injury by accident, and \$1,000,000 each employee for injury by disease. The workers' compensation policy must be endorsed with a waiver of subrogation in favor of "Park City Municipal Corporation" for all work performed by the Contractor, its employees, agents, and Subcontractors.

D. Builder's Risk Insurance (Course of Construction) (at PCMC's discretion). Contractor shall maintain Builder's Risk (Course of Construction) insurance utilizing an "All Risk" (Special Perils) coverage form, with limits equal to the completed value of the project and no coinsurance penalty provisions. Such coverage shall name "Park City Municipal Corporation" as an additional insured.

E. Contractor's Pollution Liability (at PCMC's discretion). Contractor shall maintain Contractors Pollution Liability insurance, on an occurrence basis, with limits of \$1,000,000 per occurrence and \$2,000,000 aggregate, covering third-party injury and property damage claims, including clean-up costs, as a result of pollution conditions arising from the Contractor's operations and completed operations. This coverage must include an Over the Road Pollution enhancement. The insurance shall be maintained for no less than three years after final completion.

F. The general liability, auto liability, builder's risk (if applicable), and contractor's pollution liability insurance policies are to contain, or be endorsed to contain, the following provisions:

Park City Municipal Corporation, its officers, officials, employees, and volunteers are to be covered as additional insureds on the policy with respect to liability arising out of work or operations and completed operations performed by or on behalf of the Contractor including materials, parts, or equipment furnished in connection with such work or operations and automobiles owned, leased, hired, or borrowed by or on behalf of the Contractor.

G. Should any of the above-described policies be cancelled before the expiration date thereof, notice will be delivered in accordance with the policy provisions. PCMC reserves the right to request certified copies of any required policies.

H. The Contractor's insurance shall contain a clause stating that coverage shall apply separately to each insured against whom claim is made or suit is brought, except with respect to the limits of the insurer's liability.

I. For any claims related to this Construction Agreement, the Contractor's insurance coverage shall be primary insurance coverage with respect to PCMC, its officers, officials, employees, and volunteers. Any insurance or self-insurance maintained by PCMC, its officers, officials, employees, or volunteers shall be excess of the Contractor's insurance and shall not contribute with it.

SECTION 4. AGREEMENT AMOUNT, ACCEPTANCE OF WHOLE, ADDITIONS. PCMC shall pay Contractor a total sum not to exceed **(\$ numerically)** ("Agreement Amount") for all work and materials expended to complete this Project, which shall include the cost of all bonds, insurance, and all charges, fees, permits (including water and sewer fees, unless waived), expenses or assessments of whatever kind or character that are or may be necessary to complete this Project, including any additive alternates listed within the scope of work described in Section 1.

SECTION 5. PERMITS AND FEES. As set out in Section 4 above, the Agreement Amount includes the price of all normally applicable fees and permits. PCMC may, at its discretion, arrange for the waiver of certain fees, permits and expenses.

SECTION 6. TERMS OF PAYMENT. PCMC shall pay for services provided hereunder according to and in an aggregate amount not to exceed the Agreement Amount or as detailed in an attached payment schedule (if attached, will be **Attachment A**) and only upon Contractor's request on forms approved by and submitted to the Project Manager. PCMC shall make payment within 30 days thereafter. Requests for a more rapid payment may be considered if a discount is offered for early payment. At no time shall the aggregate amount of money paid to the Contractor in proportion to the Agreement Amount be greater than the proportion of the work performed at that point to the total Project work. No payment shall be made for any service rendered by the Contractor except for services set forth and identified in this Agreement. PCMC reserves the right to withhold payment in whole or part from the Contractor for non-compliance with the provisions of the Contract Documents.

A. Retainage. PCMC may, in its sole discretion (1) retain 5% of the value of all work done and materials or equipment supplied as part security for the fulfillment of the Agreement by the Contractor; or (2) retain the final payment of up to 5% of the total Project amount. As work nears completion and solely at PCMC's discretion, PCMC may reduce the retainage to an amount more in line with the work remaining. PCMC reserves the right to retain all amounts previously withheld or due, including any liquidated damages, until all services specified herein are complete. Any money withheld pursuant to this section shall be placed in an interest bearing account and the interest shall also be payable to the Contractor upon final payment.

Before final payment is made, the Contractor must submit evidence satisfactory to PCMC that all payrolls, material bills, subcontracts and all outstanding indebtedness in connection with the Project have been paid for.

PCMC may withhold a reasonable amount of the payment bond sufficient to cover any outstanding indebtedness or monies owed or claimed by any person who supplied work or materials to the Project plus 10% of such indebtedness as PCMC's cost of administering such claims until Contractor supplies a release satisfactory to PCMC, signed by all persons who have supplied labor or materials to the Project or, at PCMC's option if no claim is made, until 105 days after the date on which any person performed the last of the labor or supplied the last of the material for the Project and upon written request from the Contractor.

The Contractor shall supply to the Project Manager/Engineer within a reasonable time after his/her request a signed statement verifying all the suppliers, subcontractors, and other persons who have supplied labor or materials to the Project.

B. Final Payment. Acceptance by the Contractor of the final payment from PCMC shall release PCMC of all claims, demands and liability of the Contractor, its officers, agents, employees and subcontractors, whether communicated or not by the Contractor, except with respect to those matters referred to in writing delivered to the Contractor and approved in a signed writing by the Project Manager.

SECTION 7. COMPLETION TIME. The work on this Project shall commence within 10 days of receipt of the Notice to Proceed and shall be completed **by October 31, 2024.** Work stoppage due to inclement weather conditions and other factors must be approved in writing by the Project Manager. Inclement weather shall not otherwise constitute cause for delay. Unless otherwise agreed by PCMC by change order, no damages shall become due to Contractor for PCMC-caused delay. A change order for delay will generally be accepted for delay so excessive and unreasonable that it is beyond the scope of the Agreement or delay attributed to direct, active or willful interference by PCMC. The change order must be based upon actual damages sustained by the Contractor which are directly attributed to the delay.

In the event that Contractor fails to complete all of the work required herein within the time limit set out above, then for each partial or complete day during which the work remains uncompleted thereafter, the Contractor agrees to pay PCMC **\$100.00 (_____ - Contractor Initials)** which the parties believe, due to the difficulty of actually assessing the damages PCMC will suffer in the event of such a delay, is a fair estimate of the loss PCMC will suffer. The parties agree that the daily liquidated damages provided for herein is reasonable and fair, and is not a penalty. **TIME IS OF THE ESSENCE IN THIS AGREEMENT.**

SECTION 8. ADDITIONAL WORK/CHANGE ORDERS. PCMC may enlarge or reduce the work to be performed by Contractor hereunder by written notification to Contractor, including changes to the plans and specifications. PCMC shall pay Contractor for any additional work so requested, and shall reduce the payment to the Contractor for any reduction in labor, materials, overhead and profit margin resulting from the reduction in the work. Except as PCMC shall so notify the Contractor in writing, it is understood and agreed by the parties hereto that no money will be paid to the Contractor for any new or additional labor or materials furnished unless a written modification is agreed to in a document signed by both parties.

The value of any work covered by a change order or of any claim for increase or decrease in the Agreement Amount shall be determined by one or more of the following methods in order of precedence listed below:

- A.** An agreed lump sum; or in the event the parties cannot agree; then
- B.** The unit rate for the work bid by the Contractor, if applicable, or in the event there was no such rate bid; then
- C.** The actual cost for: (1) labor; (2) materials; (3) supplies; (4) equipment; (5) direct overhead (not to exceed 5% of the sum total of items 1–4, unless approved by PCMC);

and (6) other services necessary and approved by PCMC to complete the work. In the event of a net increase in the Agreement Amount for a change order as a whole, PCMC shall allow a payment to the Contractor of an additional 10% of the actual cost of the work, not including direct overhead or bond costs, to cover the cost of general overhead and profit. The Contractor may also charge PCMC for actual cost of the net increase in bond costs as a result of the overall change to the Agreement Amount. PCMC specifically reserves the right to request documentation, including, but not limited to, payroll stubs, bond bills, and invoices, to validate the Contractor's calculations.

SECTION 9. DISPUTES. Except as otherwise provided in this Agreement, any disputes concerning a question of fact arising under this Agreement which are not disposed of by agreement shall be decided by PCMC. The decision of PCMC shall be final and conclusive unless, within 30 days from the date of receipt of such decision, the Contractor shall mail or otherwise furnish PCMC a written signed appeal addressed to the Project Manager/Engineer. In connection with any appeal proceeding under this clause, the Contractor will be afforded an opportunity to be heard and to offer evidence in support of its appeal. Pending final decision of a dispute hereunder, the Contractor will proceed diligently with the performance of this Agreement and in accordance with PCMC's decision. The decision of PCMC shall be final and conclusive, but shall not be arbitrary or unreasonable. Although this Agreement has been drafted by PCMC, the Contractor expressly agrees that any ambiguity herein shall be resolved in favor of PCMC.

SECTION 10. DEFAULT, REMEDY AND TERMINATION. PCMC may terminate this Agreement upon the occurrence of one or more of the following events:

- A. If Contractor or any subcontractor should substantially violate any of the provisions of this Agreement;
- B. If Contractor substantially fails to perform any part of this Agreement;
- C. If Contractor repeatedly fails or becomes unable to perform the services under this Agreement as required herein, or substantially fails to provide services under this Agreement for a period of 72 hours;
- D. If Contractor (1) shall become insolvent in a bankruptcy case; (2) shall be generally not paying its debts as they become due, or within a reasonable time thereafter; (3) shall suffer, voluntarily or involuntarily, the entry of an order by any court or governmental authority authorizing the appointment of or appointing of a custodian (as that term is defined in 11 U.S.C. §101(11)), receiver, trustee, or other officer with similar powers with respect to it or any portion of its property which remains undismissed for a period of 90 days; (4) shall suffer, voluntarily or involuntarily, with or without judicial or governmental authorization, any such custodian, receiver, trustee, or other officer with similar powers to take possession of any part of its property which third party remains in possession for an excess of 90 days; (5) shall suffer, voluntarily or

involuntarily, the filing of a petition respecting an assignment for the benefit of creditors which is not dismissed for a period of 90 days; (6) shall be dissolved; (7) shall become the subject of any proceeding, suit, or action at law or in equity under or relating to any bankruptcy, reorganization or arrangement of debt, insolvency, readjustment of debt, receivership, liquidation, or dissolution law or statute or amendments thereto to be commenced by or against it or against any of its property which remains undismissed for a period of 90 days; (8) shall voluntarily suspend substantially all of its business operations; (9) shall be merged with, acquired by, or otherwise absorbed by any individual, corporation, or other business entity or organization of any kind except for any individual corporation or other business entity or organization which is controlled by, controlling, or under common control with the Contractor; or (10) shall take action for the purpose of any of the foregoing.

After serving 10 days written notice on the Contractor and its surety of its intention to terminate the services of Contractor, and if within 10 days after serving such notice, the violation is not corrected to PCMC's reasonable satisfaction, PCMC then may take over the work and prosecute it to completion by contract or by any other method it may deem advisable at the expense of the Contractor. The Contractor and the bonding company shall be liable to PCMC for any reasonable cost occasioned by PCMC in excess of the amount agreed to for the service herein.

The Contractor shall be entitled to a hearing before a PCMC hearing officer upon the issue of termination if it submits a written request therefore within seven days of the service of the notice of PCMC's intent to terminate. The Contractor shall be entitled to be heard at such hearing on the issue of termination. The Contractor shall not bring an action against PCMC, its officers, agents or employees arising out of or relating to the termination of this Agreement before the decision is issued by PCMC's hearing officer(s).

Waiver of any default shall not be deemed to be a waiver of any subsequent default. Waiver of any provision of this Agreement shall not be construed to be modification of the terms of this Agreement, unless stated to be such in writing, signed by PCMC's authorized representative.

The Contractor shall continue the performance of this Agreement to the extent not terminated under the provisions of this section.

The rights and remedies of PCMC provided in this clause shall not be exclusive and are in addition to any other rights and remedies provided by law or under this Agreement.

SECTION 11. INDEMNIFICATION.

A. Definitions. In this Agreement, the following definitions apply:

(1) **"Indemnifiable Losses"** means the aggregate of Losses and Litigation Expenses.

- (2) **“Litigation Expense”** means any reasonable out-of-pocket expense incurred in defending a Proceeding or in any related investigation or negotiation, including court filing fees, court costs, arbitration fees, witness fees, and attorneys’ and other professionals’ fees and disbursements.
- (3) **“Loss”** means any amount awarded in, or paid in settlement of, any Proceeding, including any interest but excluding any Litigation Expenses.
- (4) **“Proceeding”** means any investigation, claim, judicial, administrative, or arbitration action or lawsuit, or other cause of action of every kind or character, brought by third parties against PCMC, its agents, employees, or officers, that arises out of this Agreement or the performance of this Agreement by Contractor or its Subcontractors or subconsultants of any tier, or anyone acting under Contractor’s direction or control, including after the expiration or termination of this Agreement.

B. Indemnification. Contractor shall indemnify PCMC and its agents, employees, and officers against all Indemnifiable Losses arising out of a Proceeding, except to the extent the Indemnifiable Losses were caused by the negligence or willful misconduct of PCMC.

C. Obligation to Defend. Contractor shall, at its sole cost and expense, defend PCMC and its agents, employees, and officers from and against all Proceedings, provided that Contractor is not required to defend PCMC from any Proceeding arising from the sole negligence of PCMC or its agents, employees, or officers.

D. Tender. Contractor’s obligation to defend will arise upon PCMC’s tender of defense to Contractor in writing. If PCMC fails to timely notify Contractor of a Proceeding, Contractor will be relieved of its indemnification obligations to the extent that Contractor was prejudiced by that failure. Upon receipt of PCMC’s tender of defense, if Contractor does not promptly notify PCMC of its acceptance of the defense and thereafter duly and diligently defend PCMC and its agents, employees, and officers, then Contractor shall pay and be liable for the reasonable costs, expenses, and attorneys’ fees incurred in defending the Proceeding and enforcing this provision.

E. Legal Counsel. To assume the defense, Contractor must notify PCMC of their intent to do so. Promptly thereafter, Contractor shall retain independent legal counsel that is reasonably acceptable to PCMC.

F. Settlement. After Contractor assumes the defense of a Proceeding, Contractor may contest, pay, or settle the Proceeding without the consent of PCMC only if that settlement (1) does not entail any admission on the part of PCMC that it violated any law or infringed the rights of any person, (2) provides as the claimant’s sole relief monetary damages that are paid in full by Contractor, and (3) requires that the claimant

release PCMC and its agents, employees, and officers from all liability alleged in the Proceeding.

G. Waiver. Contractor expressly agrees that the indemnification provision herein constitutes the Contractor's waiver of immunity under Utah Code § 34A-2-105 for the purposes of this Agreement. This waiver has been mutually negotiated by the parties. The provisions of this section shall survive the expiration or termination of this Agreement. No liability shall attach to PCMC by reason of entering into this Agreement except as expressly provided herein.

H. No Limitation. The indemnification obligations of this Agreement shall not be reduced by a limitation on the amount or type of damages, compensation, or benefits payable by or for the Contractor or Subcontractor under workers' compensation acts, disability benefits acts, or other employee benefit acts.

I. Interpretation. The parties intend that the indemnity and defense provisions in this Article shall be interpreted so as to be enforceable to the fullest extent permitted by law, but nothing herein shall be interpreted to violate public policy.

J. Environmental Indemnity. Contractor shall indemnify PCMC, its agents, employees, and officers for any Indemnifiable Losses from a Proceeding arising out of Contractor's violation of federal, state, or local environmental laws or regulations, and shall include but not be limited to all cleanup and remedial costs, diminution in value of property, and any fines or fees imposed as a result.

SECTION 12. CONTROLLING LAW AND ATTORNEY FEES AND COSTS. These general conditions shall be construed in accordance with and enforced under the laws of the State of Utah. Any action of law, suit in equity, or judicial proceeding for the enforcement of the Agreement, or any provisions thereof, shall be instituted and maintained only in any of the courts of competent jurisdiction in Summit County, Utah. If any legal proceeding is brought for the enforcement of this Agreement, or because of a dispute, breach, default, or misrepresentation in connection with any of the provisions of this Agreement, the prevailing party shall be entitled to recover from the other party, in addition to any other relief to which such party may be entitled, reasonable attorney's fees and other costs incurred in connection with that action or proceeding.

SECTION 13. ASSIGNMENT. The Contractor shall not assign nor transfer any interest in this Agreement without the prior written consent of PCMC, provided however, that claims for compensation due or to become due the Contractor from PCMC under this Agreement may be assigned to a bank, trust company, or other financial institution without such approval. Written notice of any such assignment shall be promptly furnished to PCMC.

SECTION 14. SAFETY AND TRAFFIC CONTROL. Contractor shall take all reasonable precautions to protect the safety of pedestrians, school children, motorists, and others who may use or

come near to the Project site, including, but not limited to, compliance with the Manual of Uniform Traffic Control Devices.

SECTION 15. SAFETY AND PROTECTION OF THE WORK. Contractor shall be responsible for initiating, maintaining and supervising all safety precautions and programs in connection with the Project work. Contractor shall provide reasonable protection to prevent damage, injury or loss to employees on the Project work and all other persons who may be affected thereby, materials and equipment, whether on or off the site, and other property at the work site or adjacent thereto, including trees, shrubs, lawns, walks, pavements, roadways, structures and utilities not designated for removal, relocation or replacement in the course of construction. In addition, the Contractor shall give all notices and comply with all applicable laws, ordinances, rules, regulations and lawful orders of any public authority bearing on the safety of persons or property or their protection from damage, injury or loss.

The Contractor shall erect and maintain, as required by the existing conditions and progress of the work, all reasonable safeguards for safety and protection, including posting danger signs and other warnings against hazards, setting safety regulations, and notifying owners and user of adjacent utilities.

The Contractor shall promptly remedy all damage or loss to any property referred to in this section caused in whole or in part by the Contractor, any subcontractor, or anyone directly or indirectly employed by any of them, or by anyone for whose acts any of them may be liable and for which the Contractor is responsible, except for acts or omissions by PCMC or anyone directly or indirectly employed by it, or by anyone for whose acts it may be liable, and not attributable to the fault or negligence of the Contractor. Contractor shall remove from the site all cuttings, debris, equipment and unused material.

SECTION 16. UNENFORCEABLE CONTRACT, WAIVERS. In the event that any provision of this Agreement shall be ruled invalid and unenforceable, the remaining provisions shall be valid and binding upon the parties. One or more waivers by either party of any provision, term, or covenant shall not be construed by the other party as a waiver of a subsequent breach of the same provision by the other party.

SECTION 17. ENTIRE AGREEMENT. This Agreement represents the entire integrated agreement between PCMC and Contractor and supersedes all prior negotiations, representations or agreements, either written or oral. This Agreement may be amended only by written modification signed by both parties.

SECTION 18. COMMENCEMENT OF WORK. Contractor will commence work as required by the specifications within 10 calendar days after receiving the Notice to Proceed.

SECTION 19. UTILITIES. The right is reserved to the owners of public utilities and franchises to enter upon the street or work site for the purpose of making repairs or changes of their property that may become necessary by the work. PCMC shall also have the privilege of

entering upon the street or work site for the purpose of repairing culverts, storm drains, water system repairs or adjustments, and any and all other necessary PCMC work.

The Contractor takes the whole risk, responsibility and expense with respect to the location of utilities, and in working with utility owners about locating, moving, repairing, and modifying utilities. All utility locations shown on the plans and specifications are approximate and are marked on the plans, if at all, only for convenience. PCMC makes no representation about the location of any such utilities, and Contractor is encouraged to contact utility companies and owners about the location of all utilities that may be impacted by or impact the Project work.

SECTION 20. HOURS AND DAYS OF WORK. All work performed by the Contractor, its subcontractors, materialmen, agents and employees shall be performed during work hours of 7:00 a.m. to 9:00 p.m. Monday through Saturday unless otherwise specified in a Conditional Use Permit or Construction Mitigation Plan. In individual Construction Mitigation Plans, the Building Official may further reduce the hours or days of work for special events or as other circumstances may reasonably warrant. When work is prohibited, no exterior construction, excavation or delivery of supplies and concrete are allowed. Interior work, however, may be allowed Monday through Sunday, with no limitation on hours for the following types of construction:

- A. Interior work on individual single-family home construction or addition projects not involving materials or supply deliveries.
- B. Construction of decks, patios, landscape walls less than four feet in height, and fences on individual single-family lots.
- C. Non-mechanized exterior painting on individual single-family residences.
- D. Non-mechanized landscaping on individual single-family residences.
- E. Survey work not involving grading or use of power equipment to cut vegetation.
- F. Extended Hours Special Permit. The Building Official may authorize extended hours for construction operations or procedures which, by their nature, require continuous operation, or modify or waive the hours of work on projects in generally isolated areas where the extended hours do not impact upon adjoining property occupants. In such cases, the Building Official shall issue a special permit identifying the extended hours. Contractor shall display the special permit on site.
- G. Special Event Regulations. The Building Official and/or Police Chief may, at their discretion, restrict construction activity, including governmental or special improvement agencies, in order to assure the public safety during special events within Park City. Special events shall include, but not be limited to, the Art Festival, Film Festival, ski events, and holiday events.

SECTION 21. CONSTRUCTION PLANS. Contractor shall submit a Construction Mitigation Plan to be approved by the City Engineer or his/her designee, for all building permits. The Community Development Department may waive this requirement for minor remodels, additions and interior construction where the impact on adjacent property is minimal. This plan shall be written and shall address, to the satisfaction of the City Engineer or his/her designee:

- A. Hours and Days of Operation.** The Construction Mitigation Plan shall specify the daily construction start and finish times. Construction activity occurring outside of the times specified in Section 11-14-6 of the Park City Municipal Code may only be allowed by special permit issued by the Building Official or the City Engineer.
- B. Parking.** The Construction Mitigation Plan shall include a parking plan. Construction vehicle parking may be restricted at construction sites so as to not block reasonable public and safety vehicle access along streets and sidewalks. Construction parking in paid or permit only parking areas require the Public Works Department to review and approve a parking plan. The plan shall also include anticipated temporary parking, e.g., delivery vehicles, and large equipment parking.
- C. Deliveries.** The Construction Mitigation Plan shall identify proposed delivery locations and routes. Deliveries of construction materials and supplies including concrete may be regulated as to time and routing if such deliveries will cause unreasonable noise, parking, or access issues. In order to reduce the number of delivery trips to construction sites, the stockpiling of materials on or near the site may be required. In the case of multiple construction sites in close proximity, a common materials storage and staging site may be required.
- D. Construction Phasing.** Due to the narrow streets, small lot configuration, topography, traffic circulation, weather, construction parking and material staging problems, projects in the Historic District and other areas of Park City may be required to be phased if more than one project is under construction in close enough proximity to create public safety or nuisance problems. In cases where phasing is deemed necessary by the City Engineer or his/her designee, the first project to receive a building permit shall have priority, however, the Building Official shall have the authority to phase projects as necessary to assure efficient, timely and safe construction.
- E. Trash Management and Recycling.** Construction sites shall provide adequate storage and a program for trash removal.
- F. Control of Dust and Mud on Streets.** A program for the control of dust or other airborne debris shall be required. Provision must be made to eliminate the tracking of mud on streets and a program shall be required to remove any such mud daily.

G. Noise. Construction activity shall not exceed the noise standards as specified in Section 6-3-9 of the Park City Municipal Code.

H. Grading and Excavation. Because of the truck hauling involved in grading and excavation, restrictions on trucking routes as well as the hours of operation may be necessary to mitigate the adverse impacts from such operations. Destination and total cubic yards of excavated material shall be noted.

I. Construction Sign Requirements. A sign indicating the name of the party responsible for the Project shall be posted in a location where such sign is readable from the street or driveway to the construction site. The sign shall not exceed 12 square feet in size, six feet in height and shall not exceed a letter type of four inches. Information on the sign shall include, at a minimum:

- (1) Name, address and phone number of Contractor;
- (2) Name, address, and phone number of person responsible for the project; and
- (3) Phone number of party to call in case of emergency.

No additional fee is required for this sign.

SECTION 22. TOILET FACILITIES AND CONTAINERIZED TRASH SERVICE REQUIRED.

A. The Contractor shall obtain and maintain on the site a container of suitable size and design to hold and confine trash, scraps, and other construction related refuse created or accumulated on the site. All such construction refuse shall be maintained in a closed container at all times, until transferred to the landfill. Containers may be placed in setback areas, provided that the placement of the container does not obstruct the view of motorists on adjoining streets and thereby create traffic hazards. Contractor shall not permit accumulated debris, litter, or trash on the construction site to blow or scatter onto adjoining properties, including the public street, or to accumulate on the site outside of the container, or in transit to the landfill or dump. The owner or Contractor shall service the container as frequently as needed to prevent trash from over-flowing.

B. The Project site shall have permanent toilets, or an approved temporary toilet facility positioned in a location approved by the Building Department, at the rate of one toilet per fifteen on-site employees (1-15 employees = one toilet, 16-30 employees= two toilets and so on).

SECTION 23. OBEY LAWS.

A. The Contractor shall obey all laws, ordinances and regulations of the United States, the State of Utah, and PCMC in performing this Agreement.

- B. The Contractor shall register and participate in E-Verify, or an equivalent program. The Contractor agrees to verify employment eligibility through E-Verify, or an equivalent program, for each new employee that is employed within Utah, unless exempted by Utah Code § 63G-12-302.

SECTION 24. NONDISCRIMINATION.

Any Contractor that enters into an agreement for goods or services with PCMC or any of its boards, agencies, or departments shall:

- A. Implement an employment nondiscrimination policy prohibiting discrimination in hiring, discharging, promoting or demoting, matters of compensation, or any other employment-related decision or benefit against a person otherwise qualified, because of actual or perceived race; color; sex; pregnancy, childbirth, or pregnancy-related conditions; age, if the individual is 40 years of age or older; religion; national origin; disability; sexual orientation; gender identity; genetic information; or military status.
- B. In the performance of this Agreement, Contractor shall not discriminate on account of actual or perceived race; color; sex; pregnancy, childbirth, or pregnancy-related conditions; age, if the individual is 40 years of age or older; religion; national origin; disability; sexual orientation; gender identity; genetic information; or military status.
- C. Incorporate the foregoing provisions in all subcontracts or assignments hereunder and take such actions as may be required to ensure full compliance with the provisions of this policy.

SECTION 25. THIRD PARTY RIGHTS. Nothing herein is intended to confer rights of any kind in any third party. No member, officer, or employee of PCMC shall have any interest, direct or indirect, in this Agreement or the proceeds thereof.

SECTION 26. PROJECT MANAGER/ENGINEER. The Project Manager/Engineer for this Project is Philip Adams, or such other person designated by the City Engineer or Public Works Director to the Contractor orally or in writing.

SECTION 27. PARTIES' REPRESENTATIVES. For purposes of notice required or desired by the parties or communication involving the services under this Agreement, such notice or communication shall be deemed to have been given when personally delivered or mailed certified mail, postage pre-paid, to the parties at the following addresses:

Contractor: _____, or such other person designated in writing by the Contractor's chief administrative officer, at [address].

PCMC: Project Manager/Engineer, at P.O. Box 1480, Park City, UT 84060, or when given to such other person as either of the above representatives shall designate in writing.

The designation of any address may be changed by notice given in the same manner as provided in this section.

SECTION 28. SEVERABILITY. Should any part of this Agreement for any reason be declared invalid, such decision shall not affect the validity of any remaining provisions, which remaining provisions shall remain in force and effect as if this Agreement had been executed with the invalid portion thereof eliminated, and it is hereby declared the intention of the parties that they would have executed the remaining portion of this Agreement without including any such part, parts, or portions which may, for any reason, be hereafter declared invalid. If any provision of this Agreement is held invalid or unenforceable with respect to particular circumstances, such provision shall nevertheless remain in full force and effect in all other circumstances.

SECTION 29. COUNTERPARTS. This Agreement may be executed in counterparts, each of which will be deemed an original and all of which together will constitute one and the same instrument.

SECTION 30. ELECTRONIC SIGNATURES. Each party agrees that the signatures of the parties included in this Agreement, whether affixed on an original document manually and later electronically transmitted or whether affixed by an electronic signature through an electronic signature system such as DocuSign, are intended to authenticate this writing and to create a legal and enforceable agreement between the parties hereto.

Each party is signing this Agreement on the date stated opposite that party's signature.

PARK CITY MUNICIPAL CORPORATION, a Utah municipal corporation

Date: _____

By: _____

Matt Dias
City Manager

Attest:

City Recorder's Office

Approved as to form:

City Attorney's Office

[CONTRACTOR]

Utah Contractor License # _____

Tax ID # _____

Date: _____

By: _____

[insert name of individual signing]

[insert title of individual signing]

An authorized signer

Exhibit A

**COMPLIANCE CERTIFICATION WITH FEDERAL REQUIREMENTS
FTA Clauses and Provisions for Construction**

Contained in the documents below are contract clauses and provisions required by the Federal Transit Administration (FTA) and the Utah Department of Transportation for federally funded projects for this type of procurement.

The term AGENCY in these clauses and provisions refer to the Subrecipient of the FTA funds, who is the transit agency that is administering the project.

AGENCY: Park City Municipal Corporation (PCMC)

The Contractor hereby certifies that it will comply with all requirements listed herein.

Contractor: _____

Name: _____ Title: _____

Signature: _____ Date: _____

ACCESS TO RECORDS AND REPORTS

49 U.S.C. § 5325(g)

2 C.F.R. § 200.333

49 C.F.R. part 633

Applicability to Contracts

The record keeping and access requirements apply to all contracts funded in whole or in part with FTA funds. Under 49 U.S.C. § 5325(g), FTA has the right to examine and inspect all records, documents, and papers, including contracts, related to any FTA project financed with Federal assistance authorized by 49 U.S.C. Chapter 53.

Flow Down

The record keeping and access requirements extend to all third party contractors and their contracts at every tier and subrecipients and their subcontracts at every tier.

Clause Language

Recipients can draw on the following language for inclusion in their federally funded procurements.

Access to Records and Reports

- a. **Record Retention**. The Contractor will retain, and will require its subcontractors of all tiers to retain, complete and readily accessible records related in whole or in part to the contract, including, but not limited to, data, documents, reports, statistics, sub-agreements, leases, subcontracts, arrangements, other third party agreements of any type, and supporting materials related to those records.
- b. **Retention Period**. The Contractor agrees to comply with the record retention requirements in accordance with 2 C.F.R. § 200.333. The Contractor shall maintain all books, records, accounts and reports required under this Contract for a period of at not less than three (3) years after the date of termination or expiration of this Contract, except in the event of litigation or settlement of claims arising from the performance of this Contract, in which case records shall be maintained until the disposition of all such litigation, appeals, claims or exceptions related thereto.
- c. **Access to Records**. The Contractor agrees to provide sufficient access to FTA and its contractors to inspect and audit records and information related to performance of this contract as reasonably may be required.
- d. **Access to the Sites of Performance**. The Contractor agrees to permit FTA and its contractors access to the sites of performance under this contract as reasonably may be required.

ADA ACCESS
49 USC 531 (d)

Applicability to Contracts

The ADA Access Requirements apply to all contracts.

Applicability to Micro-Purchases

Micro-purchases are defined as those purchases under \$10,000. These requirements do not apply to micro-purchases; except for construction contracts over \$2,000.

Flow Down Requirement

The ADA Access Requirements flow down to all third party contractors and their contracts at every tier.

Clause Language

ADA Access. The Americans with Disabilities Act of 1990 (ADA) prohibits discrimination and ensures equal opportunity and access for persons with disabilities.

Access Requirements for Persons with Disabilities

Contractor shall comply with 49 USC 5301(d), stating Federal policy that the elderly and persons with disabilities have the same rights as other persons to use mass transportation services and facilities and that special efforts shall be made in planning and designing those services and facilities to implement that policy. Contractor shall also comply with all applicable requirements of Sec. 504 of the Rehabilitation Act (1973), as amended, 29 USC 794, which prohibits discrimination on the basis of handicaps, and the Americans with Disabilities Act of 1990 (ADA), as amended, 42 USC 12101 et seq., which requires that accessible facilities and services be made available to persons with disabilities, including any subsequent amendments thereto.

BONDING REQUIREMENTS

>\$250,000

(including ferry vessels)

2 C.F.R. § 200.325

31 C.F.R. part 223

Applicability to Contracts

Bonds are required for all construction or facility improvement contracts and subcontracts exceeding the simplified acquisition threshold. FTA may accept the bonding policy and requirements of the recipient if FTA has determined that the Federal interest is adequately protected. If such a determination has not been made, the following minimum requirements apply:

- a. A bid guarantee from each bidder equivalent to five percent of the bid price. The “bid guarantee” must consist of a firm commitment such as a bid bond, certified check, or other negotiable instrument accompanying a bid as assurance that the bidder will, upon acceptance of the bid, execute such contractual documents as may be required within the time specified.
- b. A performance bond on the part of the contractor for 100 percent of the contract price. A “performance bond” is one executed in connection with a contract to secure fulfillment of all the contractor’s obligations under such contract.
- c. A payment bond on the part of the contractor for 100 percent of the contract price. A “payment bond” is one executed in connection with a contract to assure payment as required by law of all persons supplying labor and material in the execution of the work provided for in the contract.

Flow Down

These requirements extend to all third party contractors and their contracts at every tier and subrecipients and their subcontracts at every tier that exceed the simplified acquisition threshold.

Clauses Language

Recipients can draw on the following language for inclusion in their federally funded procurements.

Bond Requirements

Bid Guarantee

Bidders shall furnish a bid guaranty in the form of a bid bond, or certified treasurer’s or cashier’s check issued by a responsible bank or trust company, made payable to the RECIPIENT. The amount of such guaranty shall be equal to \$\$\$\$ or X% of the total bid price.

In submitting this bid, it is understood and agreed by bidder that the RECIPIENT reserves the right to reject any and all bids, or part of any bid, and it is agreed that the Bid may not be withdrawn for a period of [90] days subsequent to the opening of bids, without the written consent of RECIPIENT.

It is also understood and agreed that if the undersigned bidder should withdraw any part or all of his bid within [90] days after the bid opening without the written consent of the RECIPIENT, or refuse or be unable to enter into this Contract as provided above, or refuse or be unable to furnish adequate and acceptable Performance and Payment Bonds, or refuse or be unable to furnish adequate and acceptable insurance, as provided above, it shall forfeit its bid guaranty to the extent RECIPIENT'S damages occasioned by such withdrawal, or refusal, or inability to enter into an agreement, or provide adequate security thereof.

It is further understood and agreed that to the extent the defaulting bidder's bid guaranty shall prove inadequate to fully recompense RECIPIENT for the damages occasioned by default, then the undersigned bidder agrees to indemnify RECIPIENT and pay over to RECIPIENT the difference between the bid guarantee and RECIPIENT'S total damages so as to make RECIPIENT whole.

The undersigned understands that any material alteration of any of the above or any of the material contained herein, other than that requested will render the bid unresponsive.

Performance Guarantee

A Performance Guarantee in the amount of **100%** of the Contract value is required by the Recipient to ensure faithful performance of the Contract. Either a Performance Bond or an Irrevocable Stand-By Letter of Credit shall be provided by the Contractor and shall remain in full force for the term of the Agreement. The successful Bidder shall certify that it will provide the requisite Performance Guarantee to the RECIPIENT within ten (10) business days from Contract execution. The RECIPIENT requires all Performance Bonds to be provided by a fully qualified surety company acceptable to the RECIPIENT and listed as a company currently authorized under 31 C.F.R. part 22 as possessing a Certificate of Authority as described hereunder. RECIPIENT may require additional performance bond protection when the contract price is increased. The increase in protection shall generally equal 100 percent of the increase in contract price. The RECIPIENT may secure additional protection by directing the Contractor to increase the amount of the existing bond or to obtain an additional bond.

If the Bidder chooses to provide a Letter of Credit as its Performance Guarantee, the Bidder shall furnish with its bid, certification that an Irrevocable Stand-By Letter of Credit will be furnished should the Bidder become the successful Contractor. The Bidder shall also provide a statement from the banking institution certifying that an Irrevocable Stand-By Letter of Credit for the action will be provided if the Contract is awarded to the Bidder. The Irrevocable Stand-By Letter of Credit will only be accepted by the RECIPIENT if:

1. A bank in good standing issues it. The RECIPIENT will not accept a Letter of Credit from an entity other than a bank.
2. It is in writing and signed by the issuing bank.
3. It conspicuously states that it is an irrevocable, non-transferable, "standby" Letter of Credit.
4. The RECIPIENT is identified as the Beneficiary.
5. It is in an amount equal to **100%** of the Contract value. This amount must be in U.S. dollars.
6. The effective date of the Letter of Credit is the same as the effective date of the Contract
7. The expiration date of the Letter of Credit coincides with the term of this Agreement.
8. It indicates that it is being issued in order to support the obligation of the Contractor to perform under the Contract. It must specifically reference the Contract between the RECIPIENT and the Contractor the work stipulated herein.

The issuing bank's obligation to pay will arise upon the presentation of the original Letter of Credit and a certificate and draft (similar to the attached forms contained in Sections X and Y) to the issuing bank's representative at a location and time to be determined by the parties. This documentation will indicate that the Contractor is in default under the Contract.

Payment Bonds

A Labor and Materials Payment Bond equal to the full value of the contract must be furnished by the contractor to Recipient as security for payment by the Contractor and subcontractors for labor, materials, and rental of equipment. The bond may be issued by a fully qualified surety company acceptable to (Recipient) and listed as a company currently authorized under 31 C.F.R. part 223 as possessing a Certificate of Authority as described thereunder.

Sample Bond Certifications

Performance Guarantee Certification

The undersigned hereby certifies that the Bidder shall provide a Performance Guarantee in accordance with the Specifications.

Designate below which form of Performance Guarantee shall be provided:

_____ Performance
Bond

_____ Irrevocable Stand-By-Letter of
Credit

BIDDER'S
NAME: _____

AUTHORIZED
SIGNATURE: _____

TITLE: _____

—

DATE: _____

—

Performance Bond

KNOW ALL MEN BY THESE PRESENTS: that

(Insert full name and address and legal title of Contractor) as Principal, hereinafter called Contractor, and

_____ (Insert full name and address or legal title of Surety) as Surety, hereinafter called Surety, are held and firmly bound unto RECIPIENT as Obligee, hereinafter called Authority, in the amount of _ Dollars (\$) for the payment whereof Contractor and Surety bind themselves, their heirs, executors, administrators, successors and assigns, jointly and severally, firmly by these presents.

WHEREAS, Contractor has by written agreement dated __, 20__ , entered into a contract with the RECIPIENT for Contract No. _____, which contract is by reference made a part hereof, and is hereinafter referred to as the Contract.

NOW, THEREFORE, THE CONDITION OF THIS OBLIGATION is such that, if Contractor shall promptly and faithfully perform said Contract, then this obligation shall be null and void; otherwise it shall remain in full force and effect.

The Surety hereby waives notice of any alteration or extension of time made by the RECIPIENT.

Whenever Contractor shall be, and is declared by the RECIPIENT to be in default under the Contract, the RECIPIENT having performed RECIPIENT'S obligations thereunder, the Surety may promptly remedy the default, or shall promptly

1. Complete the Contract in accordance with its terms and conditions, or
2. Obtain a bid or bids for completing the Contract in accordance with its terms and conditions, and upon determination by Surety of the lowest responsible bidder, or, if the RECIPIENT elects, upon determination by the RECIPIENT and the Surety jointly of the lowest responsible bidder, arrange for a contract between such bidder and the Authority, and make available as Work progresses (even though there should be a default or a succession of defaults under the contract or contracts of completion arranged under this paragraph) sufficient funds to pay the cost of completion less the balance of the contract price; but not exceeding, the amount set forth in the first paragraph hereof. The term "balance of the contract price," as used in this paragraph, shall mean the total amount payable by the RECIPIENT to Contractor under the Contract and any amendments thereto, less the amount properly paid by the RECIPIENT to Contractor.

Any suit under this bond must be instituted before the expiration of two (2) years from the date on which final payment under the Contract falls due.

No right of action shall accrue on this bond to or for the use of any person or corporation other than the RECIPIENT or the heirs, executors, administrators or successors of the RECIPIENT.

Signed and sealed this _____ day of _____ 20__ .

WITNESS

PRINCIPAL

_____(SEAL)

_____(Title)

WITNESS

SURETY

_____(SEAL)

_____(Title)

Attach hereto proof of authority of officers or agents to sign bond.

Irrevocable Stand-By Letter Of Credit Certificate

The undersigned states that he/she is _____ of the
(Title)

_____(The "Beneficiary") and hereby
(Name of Beneficiary)

Certifies on behalf of the Beneficiary to _____(the "Bank"),
with
(Name of Issuing Bank)

Reference to Irrevocable Standby Letter of Credit No. _____ Issued by the
Bank (the "Letter of Credit"), that:

1. The undersigned is duly authorized to execute and deliver this certificate on behalf of the Beneficiary.
2. The Beneficiary is making a drawing under the Letter of Credit.
3. An Event of Default has occurred under Contract No. _____
4. The amount of the draft presented with this certificate does not exceed the total maximum amount drawable today under the Letter of Credit as provided therein.

IN WITNESS WHEREOF, this certificate is executed this _____ day of _____, 20__ .

(NAME OF BENEFICIARY)

By: _____

Its: _____

Bank Draft

FOR VALUE RECEIVED

Pay on presentment to _____ the sum of
_____ Dollars (\$)
(Name of Beneficiary)

Charge the Account of _____ Irrevocably Standby Letter
of _____
(Name of Issuing Bank)

Credit No. _____ Dated: 20 _____.

To _____
(Name of Issuing Bank)

NAME OF BENEFICIARY

By _____

Its _____

BUY AMERICA REQUIREMENTS
>\$150,000

As of Feb 2011 FTA has not adopted the FAR 2.101 \$150,000 standard.

49 U.S.C. 5323(j)

49 C.F.R. part 661

Applicability to Contracts

FTA's Buy America law and regulations apply to projects that involve the purchase of more than \$150,000 of iron, steel, manufactured goods, or rolling stock to be delivered to the recipient to be used in an FTA assisted project. FTA cautions that its Buy America regulations are complex. Recipients can obtain detailed information on FTA's Buy America regulation at: [Buy America | FTA \(dot.gov\)](#)

Flow Down

The Buy America requirements flow down from FTA recipients and subrecipients to first tier contractors, who are responsible for ensuring that lower tier contractors and subcontractors are in compliance.

Clause Language

The Buy America regulation at 49 C.F.R. § 661.13 requires notification of the Buy America requirements in a recipients' bid or request for proposal for FTA funded contracts. Recipients can draw on the following language for inclusion in their federally funded procurements. Note that recipients are responsible for including the correct Buy America certification based on what they are acquiring. Recipients should not include both the rolling stock and steel, iron, or manufactured products certificates in the documents unless acquiring both in the same procurement.

Buy America

The contractor agrees to comply with 49 U.S.C. 5323(j) and 49 C.F.R. part 661, which provide that Federal funds may not be obligated unless all steel, iron, and manufactured products used in FTA funded projects are produced in the United States, unless a waiver has been granted by FTA or the product is subject to a general waiver. General waivers are listed in 49 C.F.R. § 661.7. Separate Requirements for rolling stock are set out at 49 U.S.C. 5323(j)(2)(C) and 49 C.F.R. § 661.11.

The [bidder or offeror] must submit to [Recipient] the appropriate Buy America certification below with its [bid or offer]. Bids or offers that are not accompanied by a completed Buy America certification will be rejected as nonresponsive.

In accordance with 49 C.F.R. § 661.6, for the procurement of steel, iron or manufactured products, use the certifications below.

Certificate of Compliance with Buy America Requirements

The bidder or offeror hereby certifies that it will comply with the requirements of 49 U.S.C.

5323(j)(1), and the applicable regulations in 49 C.F.R. part 661.

Date: _____

—

Signature: _____

—

Company:

Name: _____

—

Title: _____

—

Certificate of Non-Compliance with Buy America Requirements

The bidder or offeror hereby certifies that it cannot comply with the requirements of 49 U.S.C. 5323(j), but it may qualify for an exception to the requirement pursuant to 49 U.S.C. 5323(j)(2), as amended, and the applicable regulations in 49 C.F.R. § 661.7.

Date: _____

Signature:

Company: _____

Name: _____

Title: _____

In accordance with 49 C.F.R. § 661.12, for the procurement of rolling stock (including traincontrol, communication, and traction power equipment) use the following certifications:

Certificate of Compliance with Buy America Rolling Stock Requirements

The bidder or offeror hereby certifies that it will comply with the requirements of 49 U.S.C.

5323(j), and the applicable regulations of 49 C.F.R. § 661.11.

Date: _____

Signature: _____

Company: _____

Name: _____

Title: _____

Certificate of Non-Compliance with Buy America Rolling Stock Requirements

The bidder or offeror hereby certifies that it cannot comply with the requirements of 49 U.S.C. 5323(j), but may qualify for an exception to the requirement consistent with 49 U.S.C. 5323(j)(2)(C), and the applicable regulations in 49 C.F.R. § 661.7.

Date: _____

Signature: _____

Company: _____

Name: _____

Title: _____

CARGO PREFERENCE REQUIREMENTS
Involving property that may be transported by ocean vessel.

46 U.S.C. § 55305
46 C.F.R. part 381

Applicability to Contracts

The Cargo Preference Act of 1954 requirements applies to all contracts involving equipment, materials, or commodities that may be transported by ocean vessels.

Flow Down

The Cargo Preference requirements apply to all contracts involved with the transport of equipment, material, or commodities by ocean vessel.

Clause Language

The Maritime Administration (MARAD) regulations at 46 C.F.R. § 381.7 contain suggested contract clauses. Recipients can draw on the following language for inclusion in their federally funded procurements.

Cargo Preference - Use of United States-Flag Vessels

The contractor agrees:

1. to use privately owned United States-Flag commercial vessels to ship at least 50 percent of the gross tonnage (computed separately for dry bulk carriers, dry cargo liners, and tankers) involved, whenever shipping any equipment, material, or commodities pursuant to the underlying contract to the extent such vessels are available at fair and reasonable rates for United States-Flag commercial vessels;
2. to furnish within 20 working days following the date of loading for shipments originating within the United States or within 30 working days following the date of loading for shipments originating outside the United States, a legible copy of a rated, "on-board" commercial ocean bill-of-lading in English for each shipment of cargo described in the preceding paragraph to the Division of National Cargo, Office of Market Development, Maritime Administration, Washington, DC 20590 and to the FTA recipient (through the contractor in the case of a subcontractor's bill-of-lading.); and
3. to include these requirements in all subcontracts issued pursuant to this contract when the subcontract may involve the transport of equipment, material, or commodities by ocean vessel.

CIVIL RIGHTS LAWS AND REGULATIONS

Applicability to Contracts

The following Federal Civil Rights laws and regulations apply to all contracts.

1. Federal Equal Employment Opportunity (EEO) Requirements. These include, but are not limited to:

a. Nondiscrimination in Federal Public Transportation Programs. 49 U.S.C. § 5332, covering projects, programs, and activities financed under 49 U.S.C. Chapter 53, prohibits discrimination on the basis of race, color, religion, national origin, sex (including sexual orientation and gender identity), disability, or age, and prohibits discrimination in employment or business opportunity.

b. Prohibition against Employment Discrimination. Title VII of the Civil Rights Act of 1964, as amended, 42 U.S.C. § 2000e, and Executive Order No. 11246, "Equal Employment Opportunity," September 24, 1965, as amended, prohibit discrimination in employment on the basis of race, color, religion, sex, or national origin.

2. Nondiscrimination on the Basis of Sex. Title IX of the Education Amendments of 1972, as amended, 20 U.S.C. § 1681 et seq. and implementing Federal regulations, "Nondiscrimination on the Basis of Sex in Education Programs or Activities Receiving Federal Financial Assistance," 49 C.F.R. part 25 prohibit discrimination on the basis of sex.

3. Nondiscrimination on the Basis of Age. The "Age Discrimination Act of 1975," as amended, 42 U.S.C. § 6101 et seq., and Department of Health and Human Services implementing regulations, "Nondiscrimination on the Basis of Age in Programs or Activities Receiving Federal Financial Assistance," 45 C.F.R. part 90, prohibit discrimination by participants in federally assisted programs against individuals on the basis of age. The Age Discrimination in Employment Act (ADEA), 29 U.S.C. § 621 et seq., and Equal Employment Opportunity Commission (EEOC) implementing regulations, "Age Discrimination in Employment Act," 29 C.F.R. part 1625, also prohibit employment discrimination against individuals age 40 and over on the basis of age.

4. Federal Protections for Individuals with Disabilities. The Americans with Disabilities Act of 1990, as amended (ADA), 42 U.S.C. § 12101 et seq., prohibits discrimination against qualified individuals with disabilities in programs, activities, and services, and imposes specific requirements on public and private entities. Third party contractors must comply with their responsibilities under Titles I, II, III, IV, and V of the ADA in employment, public services, public accommodations, telecommunications, and other provisions, many of which are subject to regulations issued by other Federal agencies.

Flow Down

The Civil Rights requirements flow down to all third party contractors and their contracts at every tier.

Clause Language

Every federally funded contract must include an Equal Opportunity clause. Recipients can draw on the following language for inclusion in their federally funded procurements.

Civil Rights and Equal Opportunity

The AGENCY is an Equal Opportunity Employer. As such, the AGENCY agrees to comply with all applicable Federal civil rights laws and implementing regulations. Apart from inconsistent requirements imposed by Federal laws or regulations, the AGENCY agrees to comply with the requirements of 49 U.S.C. § 5323(h) (3) by not using any Federal assistance awarded by FTA to support procurements using exclusionary or discriminatory specifications.

Under this Agreement, the Contractor shall at all times comply with the following requirements and shall include these requirements in each subcontract entered into as part thereof.

- 1. Nondiscrimination.** In accordance with Federal transit law at 49 U.S.C. § 5332, the Contractor agrees that it will not discriminate against any employee or applicant for employment because of race, color, religion, national origin, sex, disability, or age. In addition, the Contractor agrees to comply with applicable Federal implementing regulations and other implementing requirements FTA may issue.
- 2. Race, Color, Religion, National Origin, Sex.** In accordance with Title VII of the Civil Rights Act, as amended, 42 U.S.C. § 2000e et seq., and Federal transit laws at 49 U.S.C. § 5332, the Contractor agrees to comply with all applicable equal employment opportunity requirements of U.S. Department of Labor (U.S. DOL) regulations, "Office of Federal Contract Compliance Programs, Equal Employment Opportunity, Department of Labor," 41 C.F.R. chapter 60, and Executive Order No. 11246, "Equal Employment Opportunity in Federal Employment," September 24, 1965, 42 U.S.C. § 2000e note, as amended by any later Executive Order that amends or supersedes it, referenced in 42U.S.C. § 2000e note. The Contractor agrees to take affirmative action to ensure that applicants are employed, and that employees are treated during employment, without regard to their race, color, religion, national origin, or sex (including sexual orientation and gender identity). Such action shall include, but not be limited to, the following: employment, promotion, demotion or transfer, recruitment or recruitment advertising, layoff or termination; rates of pay or other forms of compensation; and selection for training, including apprenticeship. In addition, the Contractor agrees to comply with any implementing requirements FTA may issue.
- 3. Age.** In accordance with the Age Discrimination in Employment Act, 29 U.S.C. §§ 621- 634, U.S. Equal Employment Opportunity Commission (U.S. EEOC) regulations, "Age Discrimination in Employment Act," 29 C.F.R. part 1625, the Age Discrimination Act of 1975, as amended, 42 U.S.C. § 6101 et seq., U.S. Health and Human Services regulations, "Nondiscrimination on the Basis of Age in Programs or Activities Receiving Federal Financial Assistance," 45 C.F.R. part 90, and Federal transit law at 49 U.S.C. § 5332, the Contractor agrees to refrain from discrimination against present and prospective employees for reason of age. In addition, the Contractor agrees to comply with any implementing requirements FTA may issue.

4. **Disabilities.** In accordance with section 504 of the Rehabilitation Act of 1973, as amended, 29 U.S.C. § 794, the Americans with Disabilities Act of 1990, as amended, 42U.S.C. § 12101 et seq., the Architectural Barriers Act of 1968, as amended, 42 U.S.C. §4151 et seq., and Federal transit law at 49 U.S.C. § 5332, the Contractor agrees that it will not discriminate against individuals on the basis of disability. In addition, the Contractor agrees to comply with any implementing requirements FTA may issue.

Title VI Attachments A and E

Title VI of the Civil Rights Act of 1964 – Non – Discrimination Notice; Attachment A NON-DISCRIMINATION NOTICE

In accordance with Title VI of the Civil Rights Act of 1964, 78 Stat. 252, 42 U.S.C 2000d to 2000d-4 and the Title 49, Code of Federal Regulations. The text below, in its entirety, is in all contracts entered into by the Department. All of the text except the final section, entitled “Incorporation of Provisions,” should be included in any contract entered into by any the Department contractor.

During the performance of this contract, for itself, its assignees and successors in interest (hereinafter referred to as the “contractor”) agrees as follows:

A. COMPLIANCE WITH TITLE VI OF THE CIVIL RIGHTS ACT OF 1964 FOR FEDERAL-AID CONTRACTS

1. **Compliance with Regulations:** The contractor shall comply with the Regulation relative to nondiscrimination in Federally-assisted programs of the Department of Transportation (hereinafter, “DOT”) Title 49, Code of Federal Regulations, Part 21, as they may be amended from time to time, (hereinafter referred to as Regulations), which are herein incorporated by reference and made a part of this contract.
2. **Nondiscrimination:** The Contractor, with regard to the work performed by it during the contract, shall not discriminate on the grounds of race, color, sex, age, disability, income status, or national origin in the selection and retention of subcontractors, including procurements of materials and leases of equipment. The contractor shall not participate either directly or indirectly in the discrimination prohibited by section 21.5 of the Regulations, including employment practices when the contract covers a program set forth in Appendix B of the Regulations.
3. **Solicitations for Subcontractors, Including Procurements of Materials and Equipment:** In all solicitations either by competitive bidding or negotiation made by the contractor for work to be performed under a subcontract, including procurements of materials or leases of equipment, each potential subcontractor or supplier shall be notified by the contractor of the contractor’s obligations under this contract and the Regulations relative to nondiscrimination on the grounds of race, color, sex, age, disability, income status, or national origin.

4. Information and Reports: The contractor shall provide all information and reports required by the Regulations or directives issued pursuant thereto, and shall permit access to its books, records, accounts, other sources of information, and its facilities as may be determined by the (Recipient) or the (Name of Appropriate Administration) to be pertinent to ascertain compliance with such Regulations, orders and instructions. Where any information required of a contractor is in the exclusive possession of another who fails or refuses to furnish this information the contractor shall so certify to the (Recipient), or the (Name of Appropriate Administration) as appropriate, and shall set forth what efforts it has made to obtain the information.
5. Sanctions for Noncompliance: In the event of the contractor's noncompliance with the nondiscrimination provisions of this contract, the (Recipient) shall impose such contract sanctions as it or the (Name of Appropriate Administration) may determine to be appropriate, including, but not limited to:
 - a. Withholding of payments to the contractor under the contract until the contractor complies, and/or
 - b. Cancellation, termination or suspension of the contract, in whole or in part.
6. Incorporation of Provisions: The contractor shall include the provisions of paragraphs (1) through (6) in every subcontract, including procurements of materials and leases of equipment, unless exempt by the Regulations, or directives issued pursuant thereto.

The contractor shall take such action with respect to any subcontractor procurement as the (Recipient) or the (Name of Appropriate Administration) may direct as a means of enforcing such provisions including sanctions for noncompliance: Provided, however, that, in the event a contractor becomes involved in, or is threatened with litigation with a subcontractor or supplier as a result of such direction, the contractor may request the (Recipient) to enter into such litigation to protect the interests of the (Recipient), and, in addition, the contractor may request the United States to enter into such litigation to protect the interests of the United States.

Title VI of the Civil Rights Act of 1964 – Non – Discrimination Notice: Attachment E

During the performance of this contract, the contractor, for itself, its assignees, and successors in interest (hereinafter referred to as the "contractor") agrees to comply with the following non-discrimination statutes and authorities; including but not limited to:

Pertinent Non-Discrimination Authorities:

Title VI of the Civil Rights Act of 1964 (42 U.S.C. § 2000d et seq., 78 stat. 252), (prohibits discrimination on the basis of race, color, national origin); and 49 CFR Part 21.

The Uniform Relocation Assistance and Real Property Acquisition Policies Act of 1970, (42 U.S.C. § 460 I), (prohibits unfair treatment of persons displaced or whose property has been acquired because of Federal or Federal-aid programs and projects);

Federal-Aid Highway Act of 1973, (23 U.S.C. § 324 et seq.), (prohibits discrimination on the basis of sex);

Section 504 of the Rehabilitation Act of 1973, (29 U.S.C. § 794 et seq.), as amended, (prohibits discrimination on the basis of disability); and 49 CFR Part 27;

The Age Discrimination Act of 1975, as amended, (42 U.S.C. § 610 et seq.), (prohibits discrimination on the basis of age);

Airport and Airway Improvement Act of 1982, (49 USC § 47 I, Section 47123), as amended, (prohibits discrimination based on race, creed, color, national origin, or sex);

The Civil Rights Restoration Act of 1987, (PL 100-209), (Broadened the scope, coverage and applicability of Title VI of the Civil Rights Act of 1964, The Age Discrimination Act of 1975 and Section 504 of the Rehabilitation Act of 1973, by expanding the definition of the terms "programs or activities" to include all of the programs or activities of the Federal-aid recipients, sub-recipients and contractors, whether such programs or activities are Federally funded or not);

Titles II and III of the Americans with Disabilities Act, which prohibit discrimination on the basis of disability in the operation of public entities, public and private transportation systems, places of public accommodation, and certain testing entities (42 U.S.C. §§ 12131 - 12189) as implemented by Department of Transportation regulations at 49 C.F.R. parts 37 and 38;

The Federal Aviation Administration's Non-discrimination statute (49 U.S.C. §47123) (prohibits discrimination on the basis of race, color, national origin, and sex);

Executive Order 12898, Federal Actions to Address Environmental Justice in Minority Populations and Low-income Populations, which ensures discrimination against minority populations by discouraging programs, policies, and activities with disproportionately high and adverse human health or environmental effects on minority and low-income populations;

Executive Order 13166, Improving Access to Services for Persons with Limited English Proficiency, and resulting agency guidance, national origin discrimination includes discrimination because of limited English proficiency (LEP). To ensure compliance with Title VI, you must take reasonable steps to ensure that LEP persons have meaningful access to your programs (70 Fed. Reg. at 74087 to 74100);

Title IX of the Education Amendments of 1972, as amended, which prohibits you from discriminating because of sex in education programs or activities (20 U.S.C. 1681 et seq).

CIVIL RIGHTS DISADVANTAGED BUSINESS ENTERPRISE (DBE)

49 C.F.R. part 26

Background and Applicability

The Disadvantaged Business Enterprise (DBE) program applies to FTA recipients receiving planning, capital and/or operating assistance that will award prime contracts (excluding transit vehicle purchases) exceeding \$250,000 in FTA funds in a Federal fiscal year. All FTA recipients above this threshold must submit a DBE program and overall triennial goal for DBE participation. The overall goal reflects the anticipated amount of DBE participation on DOT-assisted contracts. As part of its DBE program, FTA recipients must require that each transit vehicle manufacturer (TVM), as a condition of being authorized to bid or propose on FTA assisted transit vehicle procurements, certify that it has complied with the requirements of 49 C.F.R. § 26.49. Only those transit vehicle manufacturers listed on FTA's certified list of Transit Vehicle Manufacturers, or that have submitted a goal methodology to FTA that has been approved or has not been disapproved at the time of solicitation, are eligible to bid.

FTA recipients must meet the maximum feasible portion of their overall goal using race-neutral methods. Where appropriate, however, recipients are responsible for establishing DBE contract goals on individual DOT-assisted contracts. FTA recipients may use contract goals only on those DOT-assisted contracts that have subcontracting responsibilities. See 49 C.F.R. § 26.51(e). Furthermore, while FTA recipients are not required to set a contract goal on every DOT-assisted contract, they are responsible for achieving their overall program goals by administering their DBE program in good faith.

FTA recipients and third party contractors can obtain information about the DBE program at the following website locations:

[Federal Transit Administration website Disadvantaged Business Enterprise page click here](#)

[Department of Transportation website Disadvantaged Business Enterprise Program click here](#)

Flow Down

The DBE contracting requirements flow down to all third party contractors and their contracts at every tier. It is the recipient's and prime contractor's responsibility to ensure the DBE requirements are applied across the board to all subrecipients/contractors/subcontractors. Should a subcontractor fail to comply with the DBE regulations, FTA would look to the recipient to make sure it intervenes to monitor compliance. The onus for compliance is on the recipient.

Clause Language

For all DOT-assisted contracts, each FTA recipient must include assurances that third party contractors will comply with the DBE program requirements of 49 C.F.R. part 26, when applicable. The following contract clause is required in all DOT-assisted prime and subcontracts:

The contractor, subrecipient or subcontractor shall not discriminate on the basis of race, color, national origin, or sex in the performance of this contract. The contractor shall carry out applicable requirements of 49 C.F.R. part 26 in the award and administration of DOT-assisted contracts. Failure by the contractor to carry out these requirements is a material breach of this

contract, which may result in the termination of this contract or such other remedy as the recipient deems appropriate, which may include, but is not limited to:

- (1) Withholding monthly progress payments;
- (2) Assessing sanctions;
- (3) Liquidated damages; and/or
- (4) Disqualifying the contractor from future bidding as non-responsible. 49 C.F.R. § 26.13(b).

Further, recipients must establish a contract clause to require prime contractors to pay subcontractors for satisfactory performance of their contracts no later than 30 days from receipt of each payment the recipient makes to the prime contractor. 49 C.F.R. § 26.29(a). Finally, for contracts with defined DBE contract goals, each FTA recipient must include in each prime contract a provision stating that the contractor shall utilize the specific DBEs listed unless the contractor obtains the recipient's written consent; and that, unless the recipient's consent is provided, the contractor shall not be entitled to any payment for work or material unless it is performed or supplied by the listed DBE. 49 C.F.R. § 26.53(f) (1).

As an additional resource, recipients can draw on the following language for inclusion in their federally funded procurements.

Overview

It is the policy of the AGENCY and the United States Department of Transportation ("DOT") that Disadvantaged Business Enterprises ("DBE's"), as defined herein and in the Federal regulations published at 49 C.F.R. part 26, shall have an equal opportunity to participate in DOT-assisted contracts. It is also the policy of the AGENCY to:

1. Ensure nondiscrimination in the award and administration of DOT-assisted contracts;
2. Create a level playing field on which DBE's can compete fairly for DOT-assisted contracts;
3. Ensure that the DBE program is narrowly tailored in accordance with applicable law;
4. Ensure that only firms that fully meet 49 C.F.R. part 26 eligibility standards are permitted to participate as DBE's;
5. Help remove barriers to the participation of DBEs in DOT assisted contracts;
6. To promote the use of DBEs in all types of federally assisted contracts and procurement activities; and
7. Assist in the development of firms that can compete successfully in the marketplace outside the DBE program.

This Contract is subject to 49 C.F.R. part 26. Therefore, the Contractor must satisfy the requirements for DBE participation as set forth herein. These requirements are in addition to all

other equal opportunity employment requirements of this Contract. The AGENCY shall make all determinations with regard to whether or not a Bidder/Offeror is in compliance with the requirements stated herein. In assessing compliance, the AGENCY may consider during its review of the Bidder/Offeror's submission package, the Bidder/Offeror's documented history of non-compliance with DBE requirements on previous contracts with the AGENCY.

Contract Assurance

The Contractor, subrecipient or subcontractor shall not discriminate on the basis of race, color, national origin, or sex in the performance of this Contract. The Contractor shall carry out applicable requirements of 49 C.F.R. part 26 in the award and administration of DOT-assisted contracts. Failure by the Contractor to carry out these requirements is a material breach of this Contract, which may result in the termination of this Contract or such other remedy as the AGENCY deems appropriate.

DBE Participation

For the purpose of this Contract, the AGENCY will accept only DBE's who are:

1. Certified, at the time of bid opening or proposal evaluation, by the [certifying agency or the Unified Certification Program (UCP)]; or
2. An out-of-state firm who has been certified by either a local government, state government or Federal government entity authorized to certify DBE status or an agency whose DBE certification process has received FTA approval; or
3. Certified by another agency approved by the AGENCY.

DBE Participation Goal

The DBE participation goal for this Contract is set at 0.16%. This goal represents those elements of work under this Contract performed by qualified Disadvantaged Business Enterprises for amounts totaling not less than 0.16% of the total Contract price. Failure to meet the stated goal at the time of proposal submission may render the Bidder/Offeror non-responsive.

Proposed Submission

Each Bidder/Offeror, as part of its submission, shall supply the following information:

1. A completed DBE Utilization Form (see below) that indicates the percentage and dollar value of the total bid/contract amount to be supplied by Disadvantaged Business Enterprises under this Contract.
2. A list of those qualified DBE's with whom the Bidder/Offeror intends to contract for the performance of portions of the work under the Contract, the agreed price to be paid to each DBE for work, the Contract items or parts to be performed by each DBE, a proposed timetable for the performance or delivery of the Contract item, and other information as required by the DBE Participation Schedule (see below). No work shall be included in the Schedule that the Bidder/Offeror has reason to believe the listed DBE will

subcontract, at any tier, to other than another DBE. If awarded the Contract, the Bidder/Offeror may not deviate from the DBE Participation Schedule submitted in response to the bid. Any subsequent changes and/or substitutions of DBE firms will require review and written approval by the AGENCY.

3. An original DBE Letter of Intent (see below) from each DBE listed in the DBE Participation Schedule.
4. An original DBE Affidavit (see below) from each DBE stating that there has not been any change in its status since the date of its last certification.
5. A signed DBE commitment Letter within 72 hours.

Good Faith Efforts

If the Bidder/Offeror is unable to meet the goal set forth above (DBE Participation Goal), the AGENCY will consider the Bidder/Offeror's documented good faith efforts to meet the goal in determining responsiveness. The types of actions that the AGENCY will consider as part of the Bidder/Offeror's good faith efforts include, but are not limited to, the following:

1. Documented communication with the AGENCY's DBE Coordinator (questions of IFB or RFP requirements, subcontracting opportunities, appropriate certification, will be addressed in a timely fashion);
2. Pre-bid meeting attendance. At the pre-bid meeting, the AGENCY generally informs potential Bidder/Offeror's of DBE subcontracting opportunities;
3. The Bidder/Offeror's own solicitations to obtain DBE involvement in general circulation media, trade association publication, minority-focus media and other reasonable and available means within sufficient time to allow DBEs to respond to the solicitation;
4. Written notification to DBE's encouraging participation in the proposed Contract; and
5. Efforts made to identify specific portions of the work that might be performed by DBE's.

The Bidder/Offeror shall provide the following details, at a minimum, of the specific efforts it made to negotiate in good faith with DBE's for elements of the Contract:

1. The names, addresses, and telephone numbers of DBE's that were contacted;
2. A description of the information provided to targeted DBE's regarding the specifications and bid proposals for portions of the work;
3. Efforts made to assist DBE's contacted in obtaining bonding or insurance required by the Bidder or the Authority.

Further, the documentation of good faith efforts must include copies of each DBE and non-DBE subcontractor quote submitted when a non-DBE subcontractor was selected over a DBE for work on the contract. 49 C.F.R. § 26.53(b) (2) (VI). In determining whether a Bidder has made good faith efforts, the Authority may take into account the performance of other Bidders in meeting the Contract goals. For example, if the apparent successful Bidder failed to meet the goal, but meets or exceeds the average DBE participation obtained by other Bidders, the Authority may view this as evidence of the Bidder having made good faith efforts.

Administrative Reconsideration

Within five (5) business days of being informed by the AGENCY that it is not responsive or responsible because it has not documented sufficient good faith efforts, the Bidder/Offeror may request administrative reconsideration. The Bidder should make this request in writing to the AGENCY's [Contact Name]. The [Contact Name] will forward the Bidder/Offeror's request to a reconsideration official who will not have played any role in the original determination that the Bidder/Offeror did not document sufficient good faith efforts.

As part of this reconsideration, the Bidder/Offeror will have the opportunity to provide written documentation or argument concerning the issue of whether it met the goal or made adequate good faith efforts to do so. The Bidder/Offeror will have the opportunity to meet in person with the assigned reconsideration official to discuss the issue of whether it met the goal or made adequate good faith efforts to do so. The AGENCY will send the Bidder/Offeror a written decision on its reconsideration, explaining the basis for finding that the Bidder/Offeror did or did not meet the goal or make adequate good faith efforts to do so. The result of the reconsideration process is not administratively appealable to the Department of Transportation.

Termination of DBE Subcontractor

The Contractor shall not terminate the DBE subcontractor(s) listed in the DBE Participation Schedule (see below) without the AGENCY's prior written consent. The AGENCY may provide such written consent only if the Contractor has good cause to terminate the DBE firm. Before transmitting a request to terminate, the Contractor shall give notice in writing to the DBE subcontractor of its intent to terminate and the reason for the request. The Contractor shall give the DBE five days to respond to the notice and advise of the reasons why it objects to the proposed termination. When a DBE subcontractor is terminated or fails to complete its work on the Contract for any reason, the Contractor shall make good faith efforts to find another DBE subcontractor to substitute for the original DBE and immediately notify the AGENCY in writing of its efforts to replace the original DBE. These good faith efforts shall be directed at finding another DBE to perform at least the same amount of work under the Contract as the DBE that was terminated, to the extent needed to meet the Contract goal established for this procurement. Failure to comply with these requirements will be in accordance with Section 8 below (Sanctions for Violations).

Continued Compliance

The AGENCY shall monitor the Contractor's DBE compliance during the life of the Contract. In the event this procurement exceeds ninety (90) days, it will be the responsibility of the Contractor to submit quarterly written reports to the AGENCY that summarize the total DBE value for this Contract. These reports shall provide the following details:

- DBE utilization established for the Contract;
- Total value of expenditures with DBE firms for the quarter;
- The value of expenditures with each DBE firm for the quarter by race and gender;
- Total value of expenditures with DBE firms from inception of the Contract; and

- The value of expenditures with each DBE firm from the inception of the Contract by race and gender.

Reports and other correspondence must be submitted to the DBE Coordinator with copies provided to the [Agency Name1] and [Agency Name2]. Reports shall continue to be submitted quarterly until final payment is issued or until DBE participation is completed.

The successful Bidder/Offeror shall permit:

- The AGENCY to have access to necessary records to examine information as the AGENCY deems appropriate for the purpose of investigating and determining compliance with this provision, including, but not limited to, records of expenditures, invoices, and contract between the successful Bidder/Offeror and other DBE parties entered into during the life of the Contract.
- The authorized representative(s) of the AGENCY, the U.S. Department of Transportation, the Comptroller General of the United States, to inspect and audit all data and record of the Contractor relating to its performance under the Disadvantaged Business Enterprise Participation provision of this Contract.
- All data/record(s) pertaining to DBE shall be maintained as stated in Section [insert reference to record keeping requirements for the Project.]

Sanctions for Violations

If at any time the AGENCY has reason to believe that the Contractor is in violation of its obligations under this Agreement or has otherwise failed to comply with terms of this Section, the AGENCY may, in addition to pursuing any other available legal remedy, commence proceedings, which may include but are not limited to, the following:

- Suspension of any payment or part due the Contractor until such time as the issues concerning the Contractor’s compliance are resolved; and
- Termination or cancellation of the Contract, in whole or in part, unless the successful Contractor is able to demonstrate within a reasonable time that it is in compliance with the DBE terms stated herein.

DBE UTILIZATION FORM

The undersigned Bidder/Offeror has satisfied the requirements of the solicitation in the following manner (please check the appropriate space):

_____ The Bidder/Offer is committed to a minimum of _____% DBE utilization on this contract.

_____ The Bidder/Offeror (if unable to meet the DBE goal of 0.16%) is committed to a minimum of _____% DBE utilization on this contract and submits documentation demonstrating good faith efforts.

DBE PARTICIPATION SCHEDULE

The Bidder/Offeror shall complete the following information for all DBE's participating in the contract that comprises the DBE Utilization percent stated in the DBE Utilization Form. The Bidder/Offeror shall also furnish the name and telephone number of the appropriate contact person should the Authority have any questions in relation to the information furnished herein.

DBE IDENTIFICATION AND INFORMATION FORM

Name and Address	Contact Name and Telephone Number	Participation Percent (Of Total Contract Value)	Description Of Work To Be Performed	Race and Gender of Firm

DBE Goals Required by UDOT

Race Conscious Goal

At the time of bid, DBE participation is considered race-conscious on projects that are assigned a Goal for Bid Evaluation. The DBE commitment becomes a contract specification upon award. The Bidder must submit with its Bid Proposal a DBE Commitment that indicates:

- Name of DBE firm
- Work items to be performed
- Total dollar amount of commitment

If the DBE commitment does not meet or exceed the assigned goal, the Bidder must submit with the Bid Proposal documentation of good faith efforts.

Race Conscious is the committed dollar amount at the time of bid focused specifically on assisting only DBEs. UDOT Civil Rights must establish contract goals to meet the race conscious portion of its overall DBE goal. To ensure that the DBE program continues to be narrowly tailored to overcome the effects of discrimination, UDOT Civil Rights may adjust the use of contract goals as follows:

- If during the course of any year it is determined the overall goal will be exceeded, UDOT Civil Rights will reduce or eliminate the use of contract goals to the extent necessary to ensure the use of contract goals does not result in exceeding the overall goal.
- If it is determined that UDOT Civil Rights will fall short of its overall goal, then appropriate modifications in the use of race neutral and/or race conscious measures will be made to allow UDOT Civil Rights to meet the overall goal.

Race Neutral Goal

At the time of bid, DBE participation is considered race-neutral on projects that are NOT assigned a Goal (0%) for Bid Evaluation. In this instance, the DBE participation does not become a contract specification upon award. The Bidder must take equal opportunity action to allow DBEs to compete for and perform on subcontracts. Only work classifications that the Bidder will subcontract need to be considered in evaluating equal opportunity action in the bid preparation.

Race Neutral is the dollar amount that exceeds the committed amount at the time of bid and is, or can be, used to assist all small businesses. UDOT Civil Rights must meet the maximum feasible portion of its overall DBE goal by using race-neutral means of facilitating DBE participation. Race neutral DBE participation includes:

- Awarding a subcontract on a prime contract that does not carry a DBE goal,
- Awarding a subcontract on a prime contract in which the DBE was not considered in making the award even if there is a DBE goal.
- For the purposes of this part, race neutral includes gender neutrality.

Goal for Contract Performance

The Bidder's DBE Commitment becomes an attachment to the Bid Proposal and is a condition of award, and thereby becomes a contract specification.

The committed dollar amount meeting the project goal for bid evaluation will be considered race conscious participation. Any dollar amounts in excess of the project goal for bid evaluation will be considered race neutral participation.

Goal for Final Compliance

Percentages for final compliance will be based on actual payments to DBEs. Overruns and under-runs on individual contract items may require adjustments to the predetermined DBE

percentage for a project if those items were not related to DBE performance. "The predetermined percentage for a project" refers to the percentage of the Contractor's DBE Commitment that becomes a contract specification upon award.

The Continued Compliance states that the AGENCY will "monitor the Contractor's DBE compliance during the life of the Contract. In the event this procurement exceeds ninety (90) days, it will be the responsibility of the Contractor to submit quarterly written reports to the AGENCY that summarize the total DBE value for this Contract." This is specifically for procurement projects. The requirement for construction projects would be:

- The Subrecipient will monitor the Contractor's DBE compliance during the life of the Contract. It is the responsibility of the Contractor to submit regular reports to the Subrecipient that summarize the total DBE value for this Contract. The frequency and content of these reports will be designated by the Subrecipient.

Determination of DBE Contractor's Eligibility by UUCP

Any Contractor may apply to the UUCP for status as a DBE. Applications will be made on forms provided by the UUCP entitled "UNIFORM CERTIFICATION APPLICATION" or "Information for Determining DBE Joint Venture Eligibility," Form No. R-817. Application need not be made in connection with a particular bid. Only work contracted to certified DBE prime contractors or subcontractors to firms that have applied for and have been granted status as a DBE by the UUCP will be considered toward contract goals as established in Subsection A.

It will be the Contractor's responsibility to submit a DBE application so that the UUCP has time to review it. The UUCP will review applications in a timely manner, but is not committed to approve DBE status within any given period of time. The UUCP must have ample lead time to review, evaluate, and verify information provided with an application.

UDOT will maintain a UUCP Unified DBE Directory of DBE Contractors, vendors, service providers, and suppliers that is updated as changes occur for the purpose of providing a reference source to assist any bidder in meeting the requirements of this bid condition. Bidders must use the most current DBE information available on the website when submitting bids. A current UUCP DBE directory representing certified DBE Contractors is available on the Internet at (click on this link): <https://www.udot.utah.gov/connect/business/civil-rights/>

In meeting the requirements of this bid condition, bidders are in no way limited to the DBE Directory referred to above in seeking out and negotiating with the DBE Contractors and determining which items of work will be subcontracted to DBE Contractors. Bidders will exercise their own judgments in selecting any subcontractor to perform any portion of the work. DBE credit will not be allowed toward race-conscious goals for a firm or joint venture that has not been DBE certified by the UUCP.

Bidding Requirements

A DBE prime contractor's performance does not count toward fulfilling the DBE goal. A prime bidder who is a DBE contractor will meet the DBE goal by using other DBE subcontractors or by using good faith efforts.

DBE Bid Assurance

1. Race Conscious Goal
 - a. Race conscious measure or program is focused specifically on assisting only DBEs. This goal is the amount the prime must commit to DBEs at the time of bid or a good faith effort must be documented.

DBE Race Conscious Commitment

1. For a bid to be considered responsive, Bidders will submit the following information regarding DBE compliance.
2. Submit a DBE Commitment of work that will be subcontracted to certified DBE firm(s) as listed in the UUCP's Directory or DBE firms that have been approved by the UUCP prior to bid opening.
 - a. The names of DBE firms that will participate in the contract;
 - b. A specific description of the work each named DBE firm will perform (list specific bid items). Listed bid items will be considered committed in their entirety unless Bidders designate otherwise in their DBE Commitment.
 - i. If mobilization is a bid item partially committed to a DBE, indicate the dollar amount of the DBE mobilization.
 - ii. If a partial quantity is committed to a DBE, indicate the quantity committed to the DBE.
 - iii. If a partial performance of an item is committed to a DBE, explain what part of the item the DBE will perform;
 - c. The dollar amount of participation by each named DBE firm;
 - d. If the contract goal is not met, evidence of good faith efforts is required at the time of bid.
3. The DBE Commitment is to be included in the prepared bid, and said information will be kept confidential and will be reviewed to determine the apparent low bidder has either met the DBE Contract Goal or has documented acceptable Good Faith Efforts.

DBE Race Neutral Participation

1. Race Neutral DBE participation includes anytime a DBE;
 - a. wins a Prime Contract through customary bidding procedures,
 - b. is awarded a subcontract on a prime contract that does not carry a DBE goal (0% goal),
 - c. wins a subcontract from a prime contractor that did not consider its DBE status in making the award (e.g., a prime contractor that uses a strict low bid system to award subcontracts).

DBE Written Confirmation

1. Low Bidder will submit to the Civil Rights Office within three (3) work days after the bid opening written confirmation from each DBE participating in the contract as provided in

the Prime Contractor's DBE Commitment. The written confirmation will include the following information:

- a. A description of the work to be performed (list specific bid items). Listed bid items will be considered committed in their entirety unless Contractors designate otherwise in their DBE commitment.
 - i. If mobilization is a bid item that is partially committed, confirm the dollar amount of the mobilization to be performed.
 - ii. If a partial quantity is committed, confirm the quantity to be performed.
 - iii. If a partial performance of an item is committed, confirm what part of the item will be performed.
 - iv. Unit bid prices for each bid item committed to a DBE.
 - v. Total dollar amounts (mathematical extensions) for each bid item committed to a DBE
- b. The dollar amount of participation by each named DBE firm.

Counting DBE Participation Toward Goals for Performance

Subcontracts to DBEs that exceed the Goal for Bid Evaluation will be considered in part as race conscious participation and in part as race neutral participation. Any dollar amounts in excess of the Goal for Bid Evaluation will be considered as race neutral participation.

It is intended that the Contractor will utilize the subcontractors designated in the DBE Commitment in the performance of the contract. Any changes in the Contractor's DBE Commitment, such as substitution of a DBE subcontractor, substitution of contract items, or decrease in total dollar amount must be approved by the UDOT Civil Rights and must be covered by a Change Order. Unauthorized substitutions or eliminations may result in the imposition of sanctions. Failure to meet the Goal for Performance established at the time of award by the Contractor's DBE Commitment, without adequate justification, including concurrence of the subrecipient and Civil Rights Office, will result in the imposition of sanctions.

1. The subrecipient will recognize and grant DBE credit for work performed by DBE contractors ONLY in the types of work for which DBE certification has been granted by the UUCP prior to bid opening. It is necessary all Bidders refer to the UUCP DBE Directory for direction and guidance.
2. Contractors may count only the value of the work actually performed by the DBE toward the DBE goals.
 - a. Work performed by the DBE's own forces using "regular employees" and "regular equipment."
 - b. The cost of supplies and materials obtained and purchased by the DBE and equipment leased for the work of the contract.
 - c. Work that a DBE subcontracts to a lower tier DBE firm.
3. Contractors may not count toward the DBE goals:
 - a. Supplies and material purchased and equipment leased by the DBE from the prime Contractor or its affiliates or another subcontractor on the project.
 - b. Work that a DBE subcontracts to a lower tier non-DBE firm.

4. Contractors may count toward their goals only expenditures to a DBE that performs a commercially useful function in the work of the contract.
 - a. A DBE performs a “commercially useful function” when it is responsible for the execution of the work of the contract and is carrying out its responsibilities by actually performing, managing, and supervising the work involved. To perform a commercially useful function, the DBE must also be responsible, with respect to materials and supplies used on the contract, for negotiating price, determining quality and quantity, ordering the material, and installing (where applicable) and paying for the material itself.
 - b. The subrecipient will evaluate the amount of work subcontracted, industry practices, whether the amount the firm is to be paid under the contract is commensurate with the work it is actually performing and the DBE credit claimed for its performance of the work, and other relevant factors.
 - c. A DBE does not perform a commercially useful function if its role is limited to that of an extra participant in a transaction, contract, or project through which funds are passed in order to obtain the appearance of DBE participation. In determining whether a DBE is such an extra participant, the subrecipient must examine similar transactions, particularly those in which DBEs do not participate.
 - d. A DBE does not perform a commercially useful function if it does not perform or exercise responsibility for at least 30 percent of the total cost of its contract with its own workforce, or the DBE subcontracts a greater portion of the work of a contract than would be expected on the basis of normal industry practice for the type of work involved.
5. The subrecipient will use the following factors in determining whether a DBE trucking company is performing a commercially useful function:
 - a. The DBE must itself own and operate at least one fully licensed, insured, and operational truck used on the contract.
 - b. The DBE must be responsible for the management and supervision of the entire trucking arrangement for the purpose of meeting DBE goals.
 - c. The DBE receives credit for the total value of the transportation services it provides on the contract using trucks it owns, insures, and operates using drivers it employs.
 - d. The DBE may lease trucks from another DBE firm, including an owner operator who is certified as a DBE. The DBE who leases trucks from another DBE receives credit for the total value of the transportation services the lessee DBE provides on the contract.
 - e. The DBE may also lease trucks from a non-DBE firm, including from an owner operator. The DBE who leases trucks from a non-DBE is entitled to credit for the total value of the transportation services provided by non-DBE lessees as long as the DBE provides the employees for the leased trucks.
 - f. A lease must indicate the DBE has exclusive use of and control over the truck. This does not preclude the leased truck from working for others during the term of the lease with the consent of the DBE, so long as the lease gives the DBE absolute priority for use of the leased truck. Leased trucks must display the name and identification number of the DBE.

6. Contractors may count expenditures with DBEs for materials or supplies as provided in the following:
 - a. If the materials or supplies are obtained from a DBE manufacturer, 100 percent of the cost of the materials or supplies counts toward DBE goals.
 - b. For purposes of this paragraph, a manufacturer is a firm that operates or maintains a factory or establishment that produces, on the premises, the materials, supplies, articles, or equipment required under the contract and of the general character described by the specifications.
 - c. If the materials or supplies are purchased from a DBE regular dealer, 60 percent of the cost of the materials or supplies counts toward DBE goals.
 - d. For purposes of this paragraph, a regular dealer is a firm that owns, operates, or maintains a store, warehouse, or other establishment in which the materials, supplies, articles or equipment of the general character described by the specifications and required under the contract are bought, kept in stock, and regularly sold or leased to the public in the usual course of business.
 - i. To be a regular dealer, the firm must be an established, regular business that engages, as its principal business and under its own name, in the purchase and sale or lease of the products in question.
 - ii. A firm may be a regular dealer in such bulk items as petroleum products, steel, cement, gravel, stone, or asphalt without owning, operating or maintaining a place of business if the firm both owns and operates distribution equipment for the products. Any supplementing of regular dealers' own distribution equipment will be by a long-term lease agreement and not on an ad hoc or contract-by-contract basis.
 - iii. Packagers, brokers, manufacturers' representatives, or other persons or firms who arrange, or expedite transactions are not regular dealers.
 - iv. A DBE trucking company that picks up a product from a manufacturer or regular dealer and delivers the product to the Contractor performs a delivery service. Credit will not be given based on a percentage of the cost of the product; credit will be allowed only for the cost of the transportation service.
7. If the materials or supplies are purchased from a service provider, the fees or commission charged for assistance in the procurement of the materials and supplies, or fees or transportation charges for the delivery of materials or supplies, count toward the DBE goals.
 - a. A Service Provider is a business that is neither a manufacturer nor a regular dealer but simply transfers title of a product from manufacturer to ultimate purchaser or a firm that puts a product into a container for delivery. A service provider charges a fee or a commission for assistance in the procurement of the materials and supplies, or fees or transportation for the delivery of materials or supplies required on a job site.
 - i. Only the fees, commissions, or transportation performed by the DBE service provider count toward the DBE goals. The subrecipient must determine the fees are reasonable and not excessive as compared with fees customarily allowed for similar services.

- ii. No portion of the cost of the materials and supplies count toward the DBE goals. Documentary evidence of the supply agreements, i.e., sales contract, purchase order, etc., will be submitted to the subrecipient prior to work beginning. The agreement will set forth the estimated quantities, unit prices, total dollar amounts, material guarantees, delivery, and payment requirements including the requirements listed part E, 4, e, of this DBE Special Provision.
8. When a DBE subcontractor is terminated, or fails to complete its work on the contract for any reason, the Contractor must make good faith efforts to find another DBE subcontractor to substitute for the original DBE. Direct these good faith efforts at finding another DBE to perform at least the same amount of work under the contract as the DBE that was terminated, to the extent needed to meet the contract goal established for the project. Document the good faith efforts. If the subrecipient requests documentation under this provision, submit the documentation within 7 days, which may be extended for an additional 7 days if necessary at the request of the contractor, and the subrecipient will provide a written determination to the contractor stating whether or not good faith efforts have been demonstrated.
- a. Failure by the contractor to carry out the requirements of this part is a material breach of the contract and may result in the termination of the contract or such other remedies set forth in that section you deem appropriate if the prime contractor fails to comply with the requirements of this section.

Americans with Disabilities Act of 1990

To provide additional information about ADA to that of the Civil Rights Laws and Regulations clause in the FTA Best Practices Manual, Appendix A, see the link below to the FTA C 4710.1 Circular.

https://www.transit.dot.gov/sites/fta.dot.gov/files/docs/Final_FTA_ADA_Circular_C_4710.1.pdf

CIVIL RIGHTS EMPLOYEE PROTECTIONS

>\$2,000

49 U.S.C. § 5333(a)

40 U.S.C. §§ 3141 – 3148

29 C.F.R. part 5

18 U.S.C. § 874

29 C.F.R. part 3

40 U.S.C. §§3701-3708

29 C.F.R. part 1926

Applicability to Contracts

Certain employee protections apply to all FTA funded contracts with particular emphasis on construction related projects. The recipient will ensure that each third party contractor complies with all federal laws, regulations, and requirements, including:

1. Prevailing Wage Requirements

- a. Federal transit laws, specifically 49 U.S.C. § 5333(a), (FTA's "Davis-Bacon Related Act"); (> \$2,000)
- b. The Davis-Bacon Act, 40 U.S.C. §§ 3141 – 3144, 3146, and 3147; and
- c. U.S. DOL regulations, "Labor Standards Provisions Applicable to Contracts Covering Federally Financed and Assisted Construction (also Labor Standards Provisions Applicable to Non-construction Contracts Subject to the Contract Work Hours and Safety Standards Act)," 29 C.F.R. part 5.

2. "Anti-Kickback" Prohibitions (> \$2,000)

- a. Section 1 of the Copeland "Anti-Kickback" Act, as amended, 18 U.S.C. § 874;
- b. Section 2 of the Copeland "Anti-Kickback" Act, as amended, 40 U.S.C. § 3145; and
- c. U.S. DOL regulations, "Contractors and Subcontractors on Public Building or Public Work Financed in Whole or in part by Loans or Grants from the United States," 29 C.F.R. part 3.

3. Contract Work Hours and Safety Standards

- a. Contract Work Hours and Safety Standards Act, as amended, 40 U.S.C. §§ 3701-3708; (> \$100,000) and supplemented by Department of Labor (DOL) regulations, 29 C.F.R. part 5; and
- b. U.S. DOL regulations, "Safety and Health Regulations for Construction," 29 C.F.R. part 1926.

Flow Down

These requirements extend to all third party contractors and their contracts at every tier and subrecipients and their subcontracts at every tier. The Davis-Bacon Act and the Copeland "Anti-Kickback" Act apply to all prime construction, alteration or repair contracts in excess of \$2,000. The Contract Work Hours and Safety Standards Act apply to all FTA funded contracts in excess of \$100,000 that involve the employment of mechanics or laborers.

Clause Language

The recipient must place a copy of the current prevailing wage determination issued by the Department of Labor in each solicitation. The decision to award a contract or subcontract must be conditioned upon the acceptance of the wage determination. In addition, recipients can draw on the following language for inclusion in their federally funded procurements.

Prevailing Wage and Anti-Kickback

For all prime construction, alteration or repair contracts in excess of \$2,000 awarded by FTA, the Contractor shall comply with the Davis-Bacon Act and the Copeland "Anti-Kickback" Act.

Under 49U.S.C. § 5333(a), prevailing wage protections apply to laborers and mechanics employed on FTA assisted construction, alteration, or repair projects. The Contractor will comply with the Davis-Bacon Act, 40 U.S.C. §§ 3141-3144, and 3146-3148 as supplemented by DOL regulations at 29 C.F.R. part 5, "Labor Standards Provisions Applicable to Contracts Governing Federally Financed and Assisted Construction." In accordance with the statute, the Contractor shall pay wages to laborers and mechanics at a rate not less than the prevailing wages specified in a wage determination made by the Secretary of Labor. In addition, the Contractor agrees to pay wages not less than once a week. The Contractor shall also comply with the Copeland "Anti-Kickback" Act (40 U.S.C. § 3145), as supplemented by DOL regulations at 29 C.F.R. part 3, "Contractors and Subcontractors on Public Building or Public Work Financed in Whole or in part by Loans or Grants from the United States." The Contractor is prohibited from inducing, by any means, any person employed in the construction, completion, or repair of public work, to give up any part of the compensation to which he or she is otherwise entitled.

Contract Work Hours and Safety Standards

For all contracts in excess of \$100,000 that involve the employment of mechanics or laborers, the Contractor shall comply with the Contract Work Hours and Safety Standards Act (40 U.S.C. §§ 3701- 3708), as supplemented by the DOL regulations at 29 C.F.R. part 5. Under 40 U.S.C. § 3702 of the Act, the Contractor shall compute the wages of every mechanic and laborer, including watchmen and guards, on the basis of a standard work week of 40 hours. Work in excess of the standard work week is permissible provided that the worker is compensated at a rate of not less than one and a half times the basic rate of pay for all hours worked in excess of 40 hours in the work week. The requirements of 40U.S.C. § 3704 are applicable to construction work and provide that no laborer or mechanic be required to work in surroundings or under working conditions which are unsanitary, hazardous or dangerous. These requirements do not apply to the purchase of supplies or materials or articles ordinarily available on the open market, or to contracts for transportation or transmission of intelligence.

In the event of any violation of the clause set forth herein, the Contractor and any subcontractor responsible therefore shall be liable for the unpaid wages. In addition, the Contractor and subcontractor shall be liable to the United States (in the case of work done under contract for the District of Columbia or a territory, to such District or to such territory), for liquidated damages. Such liquidated damages shall be computed with respect to each individual laborer or mechanic, including watchmen and guards, employed in violation of this clause in the sum of \$10 for each calendar day on which such individual was required or permitted to work in excess of the standard workweek of forty hours without payment of the overtime wages required by this clause.

The FTA shall upon its own action or upon written request of an authorized representative of the Department of Labor withhold or cause to be withheld, from any moneys payable on account of work performed by the Contractor or subcontractor under any such contract or any other Federal contract with the same prime Contractor, or any other federally-assisted contract subject

to the Contract Work Hours and Safety Standards Act, which is held by the same prime Contractor, such sums as may be determined to be necessary to satisfy any liabilities of such Contractor or subcontractor for unpaid wages and liquidated damages as provided in this section.

The Contractor or subcontractor shall insert in any subcontracts the clauses set forth in this section and also a clause requiring the subcontractors to include these clauses in any lower tier subcontracts. The prime Contractor shall be responsible for compliance by any subcontractor or lower tier subcontractor with the clauses set forth in this agreement.

Contract Work Hours and Safety Standards for Awards Not Involving Construction

The Contractor shall comply with all federal laws, regulations, and requirements providing wage and hour protections for non-construction employees, in accordance with 40 U.S.C. § 3702, Contract Work Hours and Safety Standards Act, and other relevant parts of that Act, 40 U.S.C. § 3701 et seq., and U.S. DOL regulations, "Labor Standards Provisions Applicable to Contracts Covering Federally Financed and Assisted Construction (also Labor Standards Provisions Applicable to Non-construction Contracts Subject to the Contract Work Hours and Safety Standards Act)," 29 C.F.R. part 5.

The Contractor shall maintain payrolls and basic payroll records during the course of the work and shall preserve them for a period of three (3) years from the completion of the contract for all laborers and mechanics, including guards and watchmen, working on the contract. Such records shall contain the name and address of each such employee, social security number, correct classifications, hourly rates of wages paid, daily and weekly number of hours worked, deductions made, and actual wages paid.

Such records maintained under this paragraph shall be made available by the Contractor for inspection, copying, or transcription by authorized representatives of the FTA and the Department of Labor, and the Contractor will permit such representatives to interview employees during working hours on the job.

The contractor shall require the inclusion of the language of this clause within subcontracts of all tiers.

CIVIL RIGHTS PROMPT PAYMENT

All non TVM purchases

49 CFR Part 26.29

Prompt payment for the work accomplished is an integral part of the concept of a commercially useful function but is a requirement on all FTA projects for DBE and non-DBE companies.

- Prompt payment means that the prime contractor is to pay each subcontractor, and each subcontractor is to pay any lower tier subcontractor, within 30 days of being paid by the Subrecipient.
- Prompt payment entries are to be entered for each subcontractor in the method approved so that it can be monitored and verified for compliance.

CLEAN AIR ACT AND FEDERAL WATER POLLUTION CONTROL ACT

>\$150,000

42 U.S.C. §§ 7401 – 7671q

33 U.S.C. §§ 1251-1387

2 C.F.R. part 200, Appendix II (G)

Applicability to Contracts

The Clean Air and Clean Water Act requirements apply to each contract and subcontract exceeding \$150,000. Each contract and subcontract must contain a provision that requires the recipient to agree to comply with all applicable standards, orders or regulations issued pursuant to the Clean Air Act (42 U.S.C. 7401–7671q) and the Federal Water Pollution Control Act as amended (33 U.S.C. 1251– 1387). Violations must be reported to the Federal awarding agency and the Regional Office of the Environmental Protection Agency (EPA).

Flow Down

The Clean Air Act and Federal Water Pollution Control Act requirements extend to all third party contractors and their contracts at every tier and subrecipients and their subcontracts at every tier.

Clause Language

Recipients can draw on the following language for inclusion in their federally funded procurements.

The Contractor agrees:

- 1) It will not use any violating facilities;
- 2) It will report the use of facilities placed on or likely to be placed on the U.S. EPA "List of Violating Facilities;"
- 3) It will report violations of use of prohibited facilities to FTA; and
- 4) It will comply with the inspection and other requirements of the Clean Air Act, as amended, (42 U.S.C. §§ 7401 – 7671q); and the Federal Water Pollution Control Act as amended, (33 U.S.C. §§ 1251-1387).

DISPUTES, BREACHES, DEFAULTS, AND LITIGATION

(a) FTA Interest. FTA has a vested interest in the settlement of any violation of federal law, regulation, or requirement, or any disagreement involving the Award, the accompanying Underlying Agreement, and any Amendments thereto including, but not limited to, a default, breach, major dispute, or litigation, and FTA reserves the right to concur in any settlement or compromise.

(b) Notification to FTA; Flow Down Requirement. If a current or prospective legal matter that may affect the Federal Government emerges, the Recipient must promptly notify the FTA Chief Counsel and FTA Regional Counsel for the Region in which the Recipient is located. The Recipient must include a similar notification requirement in its Third Party Agreements and must require each Third Party Participant to include an equivalent provision in its sub agreements at every tier, for any agreement that is a "covered transaction" according to 2 C.F.R. §§ 180.220 and 1200.220.

(1) The types of legal matters that require notification include, but are not limited to, a major dispute, breach, default, litigation, or naming the Federal 95 Government as a party to litigation or a legal disagreement in any forum for any reason.

(2) Matters that may affect the Federal Government include, but are not limited to, the Federal Government's interests in the Award, the accompanying Underlying Agreement, and any Amendments thereto, or the Federal Government's administration or enforcement of federal laws, regulations, and requirements.

(3) Additional Notice to U.S. DOT Inspector General. The Recipient must promptly notify the U.S. DOT Inspector General in addition to the FTA Chief Counsel or Regional Counsel for the Region in which the Recipient is located, if the Recipient has knowledge of potential fraud, waste, or abuse occurring on a Project receiving assistance from FTA. The notification provision applies if a person has or may have submitted a false claim under the False Claims Act, 31 U.S.C. § 3729, et seq., or has or may have committed a criminal or civil violation of law pertaining to such matters as fraud, conflict of interest, bid rigging, misappropriation or embezzlement, bribery, gratuity, or similar misconduct involving federal assistance. This responsibility occurs whether the Project is subject to this Agreement or another agreement between the Recipient and FTA, or an agreement involving a principal, officer, employee, agent, or Third Party Participant of the Recipient. It also applies to subcontractors at any tier. Knowledge, as used in this paragraph, includes, but is not limited to, knowledge of a criminal or civil investigation by a Federal, state, or local law enforcement or other investigative agency, a criminal indictment or civil complaint, or probable cause that could support a criminal indictment, or any other credible information in the possession of the Recipient. In this paragraph, "promptly" means to refer information without delay and without change. This notification provision applies to all divisions of the Recipient, including divisions tasked with law enforcement or investigatory functions.

(c) Federal Interest in Recovery. The Federal Government retains the right to a proportionate share of any proceeds recovered from any third party, based on the percentage of the federal share for the Underlying Agreement. Notwithstanding the preceding sentence, the Recipient may return all liquidated damages it receives to its Award Budget for its Underlying Agreement rather than return the federal share of those liquidated damages to the Federal Government, provided that the Recipient receives FTA's prior written concurrence.

(d) Enforcement. The Recipient must pursue its legal rights and remedies available under any third party agreement or any federal, state, or local law or regulation.

ENERGY CONSERVATION

42 U.S.C. 6321 et seq.
49 C.F.R. part 622, subpart C

Applicability to Contracts

The Energy Policy and Conservation requirements are applicable to all contracts. The Recipient agrees to, and assures that its subrecipients, if any, will comply with the mandatory energy standards and policies of its state energy conservation plans under the Energy Policy and Conservation Act, as amended, 42 U.S.C. § 6201 et seq., and perform an energy assessment for any building constructed, reconstructed, or modified with federal assistance as required under FTA regulations, "Requirements for Energy Assessments," 49 C.F.R. part 622, subpart C.

Flow Down

These requirements extend to all third party contractors and their contracts at every tier and

subrecipients and their subcontracts at every tier.

Clause Language

No specific clause is recommended in the regulations because the Energy Conservation requirements are so dependent on the state energy conservation plan. Recipients can draw on the following language for inclusion in their federally funded procurements.

Energy Conservation

The contractor agrees to comply with mandatory standards and policies relating to energy efficiency, which are contained in the state energy conservation plan issued in compliance with the Energy Policy and Conservation Act.

FEDERAL CHANGES

2 CFR Part 1201

Applicability to Contracts

The Federal Changes requirement applies to all contracts.

Applicability to Micro-Purchases Micro-purchases are defined as those purchases under \$10,000. These requirements do not apply to micro-purchases; except for construction contracts over \$2,000.

Flow Down Requirement: The Federal Changes requirement flows down appropriately to each applicable changed requirement.

Clause Language: The following language has been developed by FTA.

Federal Changes - Contractor shall at all times comply with all applicable FTA regulations, policies, procedures and directives, including without limitation those listed directly or by reference in the Master Agreement between Purchaser and FTA, as they may be amended or promulgated from time to time during the term of this contract. Contractor's failure to so comply shall constitute a material breach of this contract.

FLY AMERICA

Foreign transportation or travel of people or goods by air

49 U.S.C. § 40118

41 C.F.R. part 301-10

48 C.F.R. part 47.4

Applicability to Contracts

The Fly America requirements apply to the transportation of persons or property, by air, between a place in the U.S. and a place outside the U.S., or between places outside the U.S., when the FTA will participate in the costs of such air transportation. Transportation on a foreign air carrier is permissible when provided by a foreign air carrier under a code share agreement when the ticket identifies the U.S. air carrier's designator code and flight number. Transportation by a foreign air carrier is also permissible if there is a bilateral or multilateral air transportation

agreement to which the U.S. Government and a foreign government are parties and which the U.S. DOT has determined meets the requirements of the Fly America Act.

Flow Down Requirements

The Fly America requirements flow down from FTA recipients and subrecipients to first tier contractors who are responsible for ensuring that lower tier contractors and subcontractors are in compliance.

Clause Language

A sample clause is provided for Federal contracts at 48 C.F.R. 52.247-63. Recipients can draw on the following language for inclusion in their federally funded procurements.

FTA proposes the following language, modified from the Federal clause.

Fly America Requirements

- 1) Definitions. As used in this clause--
“International air transportation” means transportation by air between a place in the United States and a place outside the United States or between two places both of which are outside the United States.

“United States” means the 50 States, the District of Columbia, and outlying areas.

“U.S.-flag air carrier” means an air carrier holding a certificate under 49 U.S.C. Chapter 411.
- 2) b) When Federal funds are used to fund travel, Section 5 of the International Air Transportation Fair Competitive Practices Act of 1974 (49 U.S.C. 40118) (Fly America Act) requires contractors, recipients, and others use U.S.-flag air carriers for U.S. Government-financed international air transportation of personnel (and their personal effects) or property, to the extent that service by those carriers is available. It requires the Comptroller General of the United States, in the absence of satisfactory proof of the necessity for foreign-flag air transportation, to disallow expenditures from funds, appropriated or otherwise established for the account of the United States, for international air transportation secured aboard a foreign-flag air carrier if a U.S.-flag air carrier is available to provide such services.
- 3) If available, the Contractor, in performing work under this contract, shall use U.S.-flag carriers for international air transportation of personnel (and their personal effects) or property.
- 4) In the event that the Contractor selects a carrier other than a U.S.-flag air carrier for international air transportation, the Contractor shall include a statement on vouchers involving such transportation essentially as follows:

Statement of Unavailability of U.S.-Flag Air Carriers

International air transportation of persons (and their personal effects) or property by U.S.-flag air carrier was not available or it was necessary to use foreign-flag air carrier service for the following reasons. See FAR § 47.403. [State reasons]:

(End of statement)

5) The Contractor shall include the substance of this clause, including this paragraph (e), in each subcontract or purchase under this contract that may involve international air transportation.

(End of Clause)

GOVERNMENT-WIDE DEBARMENT AND SUSPENSION

>\$25,000

2 C.F.R. part 180

2 C.F.R part 1200

2 C.F.R. § 200.213

2 C.F.R. part 200 Appendix II (I)

Executive Order 12549

Executive Order 12689

Background and Applicability

A contract award (of any tier) in an amount expected to equal or exceed \$25,000 or a contract award at any tier for a federally required audit (irrespective of the contract amount) must not be made to parties listed on the government-wide exclusions in the System for Award Management (SAM), in accordance with the OMB guidelines at 2 C.F.R. part 180. The Excluded Parties List

System in SAM contains the names of parties debarred, suspended, or otherwise excluded by agencies, as well as parties declared ineligible under statutory or regulatory authority other than Executive Order 12549.

Recipients, contractors, and subcontractors (at any level) that enter into covered transactions are required to verify that the entity (as well as its principals and affiliates) with which they propose to contract or subcontract is not excluded or disqualified. This is done by: (a) checking the SAM exclusions; (b) collecting a certification from that person; or (c) adding a clause or condition to the contract or subcontract.

Flow Down

Recipients, contractors, and subcontractors who enter into covered transactions with a participant at the next lower level, must require that participant to: (a) comply with subpart C of 2 C.F.R. part 180, as supplemented by 2 C.F.R. part 1200; and (b) pass the requirement to comply with subpart C of 2 C.F.R. part 180 to each person with whom the participant enters into a covered transaction at the next lower tier.

Clause Language

Recipients can draw on the following language for inclusion in their federally funded procurements.

Debarment, Suspension, Ineligibility and Voluntary Exclusion

The Contractor shall comply and facilitate compliance with U.S. DOT regulations, "Nonprocurement Suspension and Debarment," 2 C.F.R. part 1200, which adopts and supplements the U.S. Office of Management and Budget (U.S. OMB) "Guidelines to Agencies on Governmentwide Debarment and Suspension (Nonprocurement)," 2 C.F.R. part 180. These provisions apply to each contract at any tier of \$25,000 or more, and to each contract at any tier for a federally required audit (irrespective of the contract amount), and to each contract at any tier that must be approved by an FTA official irrespective of the contract amount. As such, the Contractor shall verify that its principals, affiliates, and subcontractors are eligible to participate in this federally funded contract and are not presently declared by any Federal department or agency to be:

- a) Debarred from participation in any federally assisted Award;
- b) Suspended from participation in any federally assisted Award;
- c) Proposed for debarment from participation in any federally assisted Award;
- d) Declared ineligible to participate in any federally assisted Award;
- e) Voluntarily excluded from participation in any federally assisted Award; or
- f) Disqualified from participation in any federally assisted Award.

By signing and submitting its bid or proposal, the bidder or proposer certifies as follows:

The certification in this clause is a material representation of fact relied upon by the AGENCY. If

it is later determined by the AGENCY that the bidder or proposer knowingly rendered an erroneous certification, in addition to remedies available to the AGENCY, the Federal Government may pursue available remedies, including but not limited to suspension and/or debarment. The bidder or proposer agrees to comply with the requirements of 2 C.F.R. part 180, subpart C, as supplemented by 2 C.F.R. part 1200, while this offer is valid and throughout the period of any contract that may arise from this offer. The bidder or proposer further agrees to include a provision requiring such compliance in its lower tier covered transactions.

_____ Signature of Contractor's Authorized Official

_____ Name and Title of Contractor's Authorized Official

_____ Date

INCORPORATION OF FEDERAL TRANSIT ADMINISTRATION (FTA) TERMS

FTA Circular 4220.1F

Applicability to Contracts

The incorporation of FTA terms applies to all contracts.

Applicability to Micro-Purchases:

Micro-purchases are defined as those purchases under \$10,000. These requirements do not apply to micro-purchases; except for construction contracts over \$2,000.

Flow Down Requirement

The incorporation of FTA terms has unlimited flow down.

Clause Language

FTA has developed the following incorporation of terms language: Incorporation of Federal Transit Administration (FTA) Terms - The preceding provisions include, in part, certain Standard Terms and Conditions required by DOT, whether or not expressly set forth in the preceding contract provisions. All contractual provisions required by DOT, as set forth in FTA Circular 4220.1F are hereby incorporated by reference. Anything to the contrary herein notwithstanding, all FTA mandated terms shall be deemed to control in the event of a conflict with other provisions contained in this Agreement. The Contractor shall not perform any act, fail to perform any act, or refuse to comply with any (name of grantee) to be in violation of the FTA terms and conditions.

LOBBYING RESTRICTIONS

>\$100,000

31 U.S.C. § 1352

2 C.F.R. § 200.450

2 C.F.R. part 200 appendix II (J)

49 C.F.R. part 20

Applicability to Contracts

The lobbying requirements apply to all contracts and subcontracts of \$100,000 or more at any tier under a Federal grant. If any funds other than Federal appropriated funds have been paid or will be paid to any person for influencing or attempting to influence an officer or employee of any agency, a Member of Congress, an officer or employee of Congress, or an employee of a Member of Congress in connection with this agreement, the payor must complete and submit

the Standard Form-LLL, "Disclosure Form to Report Lobbying," in accordance with its instructions.

Flow Down

The lobbying requirements mandate the maximum flow down pursuant to Byrd Anti-Lobbying Amendment, 31 U.S.C. § 1352(b)(5).

Clause Language

49 C.F.R. part 20, Appendices A and B provide specific language for inclusion in FTA funded third party contracts as follows:

Lobbying Restrictions

The undersigned certifies, to the best of his or her knowledge and belief, that:

1. No Federal appropriated funds have been paid or will be paid, by or on behalf of the undersigned, to any person for influencing or attempting to influence an officer or employee of an agency, a Member of Congress, an officer or employee of Congress, or an employee of a Member of Congress in connection with the awarding of any Federal contract, the making of any Federal grant, the making of any Federal loan, the entering into any cooperative agreement, and the extension, continuation, renewal, amendment, or modification of any Federal contract, grant, loan, or cooperative agreement.
2. If any funds other than Federal appropriated funds have been paid or will be paid to any person for influencing or attempting to influence an officer or employee of any agency, a Member of Congress, an officer or employee of Congress, or an employee of a Member of Congress in connection with this Federal contract, grant, loan, or cooperative agreement, the undersigned shall complete and submit Standard Form-LLL, "Disclosure Form to Report Lobbying," in accordance with its instructions.
3. The undersigned shall require that the language of this certification be included in the award documents for all sub-awards at all tiers (including subcontracts, sub-grants, and contracts under grants, loans, and cooperative agreements) and that all subrecipients shall certify and disclose accordingly.

This certification is a material representation of fact upon which reliance was placed when this transaction was made or entered into. Submission of this certification is a prerequisite for making or entering into this transaction imposed by section 1352, title 31, U.S. Code. Any person who fails to file the required certification shall be subject to a civil penalty of not less than \$10,000 and not more than \$100,000 for each such failure.

_____ Signature of Contractor's Authorized Official

_____ Name and Title of Contractor's Authorized Official

_____ Date

NATIONAL INTELLIGENT TRANSPORTATION SYSTEMS (ITS) ARCHITECTURE AND STANDARDS

23 U.S.C. Section 517(d)

23 U.S.C. §502

Intelligent transportation system (ITS) property and services must comply with the National ITS Architecture and Standards to the extent required by 23 U.S.C. Section 517(d) and FTA Notice, "FTA National ITS Architecture Policy on Transit Projects," 66 FR 1455 et seq., January 8, 2001, and later published policies or implementing directives FTA may issue. Consequently, third party contracts involving ITS are likely to require provisions to ensure compliance with Federal requirements.

NO GOVERNMENT OBLIGATION TO THIRD PARTIES

Applicability to Contracts

The No Obligation clause applies to all third party contracts that are federally funded.

Flow Down

The No Obligation clause extends to all third party contractors and their contracts at every tier and subrecipients and their subcontracts at every tier.

Clause Language

Recipients can draw on the following language for inclusion in their federally funded procurements.

No Federal Government Obligation to Third Parties.

The Recipient and Contractor acknowledge and agree that, notwithstanding any concurrence by the Federal Government in or approval of the solicitation or award of the underlying Contract, absent the express written consent by the Federal Government, the Federal Government is not a party to this Contract and shall not be subject to any obligations or liabilities to the Recipient, Contractor or any other party (whether or not a party to that contract) pertaining to any matter resulting from the underlying Contract. The Contractor agrees to include the above clause in each subcontract financed in whole or in part with Federal assistance provided by the FTA. It is further agreed that the clause shall not be modified, except to identify the subcontractor who will be subject to its provisions.

NOTIFICATION OF FEDERAL PARTICIPATION FOR STATES

Limited to states

FTA Master Agreement §37

Federal grant monies ((insert total UDOT federal grant amount)) fund this contract, in whole or in part (Section 53XX – CFDA 20.5XX). As such, agencies receiving such funds and contractors awarded contracts that use such funds must comply with certain Federal certifications and clause requirements. This includes, for purchases of rolling stock over \$150,000, compliance with Buy America Act requirements, including pre-award and post-delivery audit requirements and certifications, as well as requirements and certifications applicable under the Federal Motor Vehicle Safety Standard (FMVSS). It is the contractor's responsibility to be aware of the pertinent certifications and contract clauses, as identified by the Issuing Agency for the instant procurement and ensure compliance with such requirements prior to award and throughout the term of any resultant contract. The full text of these clauses is available at the National Rural Transit Assistance Program (RTAP) website under "ProcurementPro." The website address is: <http://www.nationalrtap.org/>

PRIVACY ACT
Contracts with personal identifier files
5 U.S.C. 552

Applicability to Contracts

When a grantee maintains files on drug and alcohol enforcement activities for FTA, and those files are organized so that information could be retrieved by personal identifier, the Privacy Act requirements apply to all contracts.

Applicability to Micro-Purchases

Micro-purchases are defined as those purchases under \$10,000. These requirements do not apply to micro-purchases; except for construction contracts over \$2,000.

Flow Down Requirement

The Federal Privacy Act requirements flow down to each third party contractor and their contracts at every tier.

Clause Language

The text of the following clause has not been mandated by statute or specific regulation, but has been developed by FTA.

Contracts Involving Federal Privacy Act Requirements - The following requirements apply to the Contractor and its employees that administer any system of records on behalf of the Federal Government under any contract:

(1) The Contractor agrees to comply with, and assures the compliance of its employees with, the information restrictions and other applicable requirements of the Privacy Act of 1974, 5 U.S.C. § 552a. Among other things, the Contractor agrees to obtain the express consent of the Federal Government before the Contractor or its employees operate a system of records on behalf of the Federal Government. The Contractor understands that the requirements of the Privacy Act, including the civil and criminal penalties for violation of that Act, apply to those individuals involved, and that failure to comply with the terms of the Privacy Act may result in termination of the underlying contract.

(2) The Contractor also agrees to include these requirements in each subcontract to administer any system of records on behalf of the Federal Government finance in whole or in part with Federal assistance provided by FTA.

PROGRAM FRAUD AND FALSE OR FRAUDULENT STATEMENTS AND RELATED ACTS

49 U.S.C. § 5323(l) (1)
31 U.S.C. §§ 3801-3812
18 U.S.C. § 1001
49 C.F.R. part 31

Applicability to Contracts

The Program Fraud clause applies to all third party contracts that are federally funded.

Flow Down

The Program Fraud clause extends to all third party contractors and their contracts at every tier and subrecipients and their subcontracts at every tier. These requirements flow down to contractors and subcontractors who make, present, or submit covered claims and statements.

Clause Language

Recipients can draw on the following language for inclusion in their federally funded procurements.

Program Fraud and False or Fraudulent Statements or Related Acts

The Contractor acknowledges that the provisions of the Program Fraud Civil Remedies Act of 1986, as amended, 31 U.S.C. § 3801 et seq. and U.S. DOT regulations, "Program Fraud Civil Remedies," 49 C.F.R. part 31, apply to its actions pertaining to this Project. Upon execution of the underlying contract, the Contractor certifies or affirms the truthfulness and accuracy of any statement it has made, it makes, it may make, or causes to be made, pertaining to the underlying contract or the FTA assisted project for which this contract work is being performed. In addition to other penalties that may be applicable, the Contractor further acknowledges that if it makes, or causes to be made, a false, fictitious, or fraudulent claim, statement, submission, or certification, the Federal Government reserves the right to impose the penalties of the Program Fraud Civil Remedies Act of 1986 on the Contractor to the extent the Federal Government deems appropriate.

The Contractor also acknowledges that if it makes, or causes to be made, a false, fictitious, or fraudulent claim, statement, submission, or certification to the Federal Government under a contract connected with a project that is financed in whole or in part with Federal assistance originally awarded by FTA under the authority of 49 U.S.C. chapter 53, the Government reserves the right to impose the penalties of 18 U.S.C. § 1001 and 49 U.S.C. § 5323(l) on the Contractor, to the extent the Federal Government deems appropriate.

The Contractor agrees to include the above two clauses in each subcontract financed in whole or in part with Federal assistance provided by FTA. It is further agreed that the clauses shall not be modified, except to identify the subcontractor who will be subject to the provisions.

**PROHIBITION ON CERTAIN TELECOMMUNICATIONS AND VIDEO SURVEILLANCE
SERVICES OR EQUIPMENT**

CFR Title 2, Subtitle A, Chapter II, Part 200, Subpart C, § 200.216.

(a) Recipients and subrecipients are prohibited from obligating or expending loan or grant funds to:

(1) Procure or obtain;

(2) Extend or renew a contract to procure or obtain; or

(3) Enter into a contract (or extend or renew a contract) to procure or obtain equipment, services, or systems that uses covered telecommunications equipment or services as a substantial or essential component of any system, or as critical technology as part of any system. As described in [Public Law 115-232](#), section 889, covered telecommunications equipment is telecommunications equipment produced by Huawei Technologies Company or ZTE Corporation (or any subsidiary or affiliate of such entities).

(i) For the purpose of public safety, security of government facilities, physical security surveillance of critical infrastructure, and other national security purposes, video surveillance and telecommunications equipment produced by Hytera Communications Corporation, Hangzhou Hikvision Digital Technology Company, or Dahua Technology Company (or any subsidiary or affiliate of such entities).

(ii) Telecommunications or video surveillance services provided by such entities or using such equipment.

(iii) Telecommunications or video surveillance equipment or services produced or provided by an entity that the Secretary of Defense, in consultation with the Director of the National Intelligence or the Director of the Federal Bureau of Investigation, reasonably believes to be an entity owned or controlled by, or otherwise connected to, the government of a covered foreign country.

(b) In implementing the prohibition under [Public Law 115-232](#), section 889, subsection (f), paragraph (1), heads of executive agencies administering loan, grant, or subsidy programs shall prioritize available funding and technical support to assist affected businesses, institutions and organizations as is reasonably necessary for those affected entities to transition from covered communications equipment and services, to procure replacement equipment and services, and to ensure that communications service to users and customers is sustained.

(c) See [Public Law 115-232](#), section 889 for additional information.

(d) See also [§ 200.471](#).

RECYCLED PRODUCTS

Contract for items designated by EPA, when procuring \$10,000 or more per year

42 U.S.C. § 6962

40 C.F.R. part 247

2 C.F.R. part § 200.322

Applicability to Contracts

The Resource Conservation and Recovery Act, as amended, (42 U.S.C. § 6962 et seq.), requires States and local governmental authorities to provide a competitive preference to products and services that conserve natural resources, protect the environment, and are energy efficient. Recipients are required to procure only items designated in guidelines of the Environmental Protection Agency (EPA) at 40 C.F.R. part 247 that contain the highest percentage of recovered materials practicable, consistent with maintaining a satisfactory level of competition, where the purchase price of the item exceeds \$10,000 or the value of the quantity acquired during the preceding fiscal year exceeded \$10,000.

Flow Down

These requirements extend to all third party contractors and their contracts at every tier and subrecipients and their subcontracts at every tier where the value of an EPA designated item exceeds \$10,000.

Clause Language

Recipients can draw on the following language for inclusion in their federally funded procurements.

Recovered Materials

The Contractor agrees to provide a preference for those products and services that conserve natural resources, protect the environment, and are energy efficient by complying with and facilitating compliance with Section 6002 of the Resource Conservation and Recovery Act, as amended, 42 U.S.C. § 6962, and U.S. Environmental Protection Agency (U.S. EPA), "Comprehensive Procurement Guideline for Products Containing Recovered Materials," 40 C.F.R. part 247.

SAFE OPERATION OF MOTOR VEHICLES

(a) Seat Belt Use. The Recipient agrees to implement Executive Order No. 13043, "Increasing Seat Belt Use in the United States," April 16, 1997, 23 U.S.C. § 402 note, (62 Fed. Reg. 19217), by:

- (1) Adopting and promoting on-the-job seat belt use policies and programs for its employees and other personnel that operate company-owned vehicles, company-rented vehicles, or personally operated vehicles; and 91
- (2) Including a "Seat Belt Use" provision in each third party agreement related to the Award.

(b) Distracted Driving, Including Text Messaging While Driving. The Recipient agrees to comply with:

- (1) Executive Order No. 13513, "Federal Leadership on Reducing Text Messaging While Driving," October 1, 2009, 23 U.S.C. § 402 note, (74 Fed. Reg. 51225);
- (2) U.S. DOT Order 3902.10, "Text Messaging While Driving," December 30, 2009; and
- (3) The following U.S. DOT Special Provision pertaining to Distracted Driving:
 - (i) Safety. The Recipient agrees to adopt and enforce workplace safety policies to decrease crashes caused by distracted drivers, including policies to ban text messaging while using an electronic device supplied by an employer, and driving a vehicle the driver owns or rents, a vehicle Recipient owns, leases, or rents, or a privately-owned vehicle when on official business in connection with the Award, or when performing any work for or on behalf of the Award;
 - (ii) Recipient Size. The Recipient agrees to conduct workplace safety initiatives in a manner commensurate with its size, such as establishing new rules and programs to prohibit text messaging while driving, re-evaluating the existing programs to prohibit text messaging while driving, and providing education, awareness, and other outreach to employees about the safety risks associated with texting while driving; and
 - (iii) Extension of Provision. The Recipient agrees to include the preceding Special Provision of section 34(b)(3)(i) – (ii) of this Master Agreement in its third party agreements, and encourage its Third Party Participants to comply with this Special Provision, and include this Special Provision in each third party subagreement at each tier supported with federal assistance.

SEISMIC SAFETY
New Buildings & additions.
42 U.S.C. 7701 et seq.
49 C.F.R. part 41
Executive Order (E.O.) 12699

Applicability to Contracts

The Seismic Safety requirements apply only to contracts for the construction of new buildings or additions to existing buildings.

Flow Down

The Seismic Safety requirements flow down from FTA recipients and subrecipients to first tier contractors to assure compliance with the applicable building standards for Seismic Safety, including the work performed by all subcontractors.

Clauses Language

Recipients can draw on the following language for inclusion in their federally funded procurements.

Seismic Safety

The contractor agrees that any new building or addition to an existing building will be designed and constructed in accordance with the standards for Seismic Safety required in Department of Transportation (DOT) Seismic Safety Regulations 49 C.F.R. part 41 and will certify to compliance to the extent required by the regulation. The contractor also agrees to ensure that all work performed under this contract, including work performed by a subcontractor, is in compliance with the standards required by the Seismic Safety regulations and the certification of compliance issued on the project.

TERMINATION

>\$10,000

2 C.F.R. § 200.339

2 C.F.R. part 200, Appendix II (B)

Applicability to Contracts

All contracts in excess of \$10,000 must address termination for cause and for convenience, including the manner by which it will be effected and the basis for settlement.

Flow Down

For all contracts in excess of \$10,000, the Termination clause extends to all third party contractors and their contracts at every tier and subrecipients and their subcontracts at every tier.

Clause Language

Recipients can draw on the following language for inclusion in their federally funded procurements.

Termination for Convenience (General Provision)

The AGENCY may terminate this contract, in whole or in part, at any time by written notice to the Contractor when it is in the AGENCY's best interest. The Contractor shall be paid its costs, including contract close-out costs, and profit on work performed up to the time of termination. The Contractor shall promptly submit its termination claim to AGENCY to be paid the Contractor. If the Contractor has any property in its possession belonging to AGENCY, the Contractor will account for the same, and dispose of it in the manner AGENCY directs.

Termination for Default [Breach or Cause] (General Provision)

If the Contractor does not deliver supplies in accordance with the contract delivery schedule, or if the contract is for services, the Contractor fails to perform in the manner called for in the contract, or if the Contractor fails to comply with any other provisions of the contract, the AGENCY may terminate this contract for default. Termination shall be effected by serving a Notice of Termination on the Contractor setting forth the manner in which the Contractor is in default. The Contractor will be paid only the contract price for supplies delivered and accepted, or services performed in accordance with the manner of performance set forth in the contract.

If it is later determined by the AGENCY that the Contractor had an excusable reason for not performing, such as a strike, fire, or flood, events which are not the fault of or are beyond the control of the Contractor, the AGENCY, after setting up a new delivery of performance schedule, may allow the Contractor to continue work, or treat the termination as a Termination for Convenience.

Opportunity to Cure (General Provision)

The AGENCY, in its sole discretion may, in the case of a termination for breach or default, allow the Contractor [an appropriately short period of time] in which to cure the defect. In such case, the Notice of Termination will state the time period in which cure is permitted and other appropriate conditions

If Contractor fails to remedy to AGENCY's satisfaction the breach or default of any of the terms, covenants, or conditions of this Contract within [10 days] after receipt by Contractor of written notice from AGENCY setting forth the nature of said breach or default, AGENCY shall have the right to terminate the contract without any further obligation to Contractor. Any such termination for default shall not in any way operate to preclude AGENCY from also pursuing all available remedies against Contractor and its sureties for said breach or default.

Waiver of Remedies for any Breach

In the event that AGENCY elects to waive its remedies for any breach by Contractor of any covenant, term or condition of this contract, such waiver by AGENCY shall not limit AGENCY's remedies for any succeeding breach of that or of any other covenant, term, or condition of this contract.

Termination for Convenience (Professional or Transit Service Contracts)

The AGENCY, by written notice, may terminate this contract, in whole or in part, when it is in the AGENCY's interest. If this contract is terminated, the AGENCY shall be liable only for payment under the payment provisions of this contract for services rendered before the effective date of termination.

Termination for Default (Supplies and Service)

If the Contractor fails to deliver supplies or to perform the services within the time specified in this contract or any extension, or if the Contractor fails to comply with any other provisions of this contract, the AGENCY may terminate this contract for default. The AGENCY shall terminate by delivering to the Contractor a Notice of Termination specifying the nature of the default. The Contractor will only be paid the contract price for supplies delivered and accepted, or services performed in accordance with the manner or performance set forth in this contract.

If, after termination for failure to fulfill contract obligations, it is determined that the Contractor was not in default, the rights and obligations of the parties shall be the same as if the termination had been issued for the convenience of the AGENCY.

Termination for Default (Transportation Services)

If the Contractor fails to pick up the commodities or to perform the services, including delivery services, within the time specified in this contract or any extension, or if the Contractor fails to comply with any other provisions of this contract, the AGENCY may terminate this contract for default. The AGENCY shall terminate by delivering to the Contractor a Notice of Termination

specifying the nature of default. The Contractor will only be paid the contract price for services performed in accordance with the manner of performance set forth in this contract.

If this contract is terminated while the Contractor has possession of AGENCY goods, the Contractor shall, upon direction of the AGENCY, protect and preserve the goods until surrendered to the AGENCY or its agent. The Contractor and AGENCY shall agree on payment for the preservation and protection of goods. Failure to agree on an amount will be resolved under the Dispute clause.

If, after termination for failure to fulfill contract obligations, it is determined that the Contractor was not in default, the rights and obligations of the parties shall be the same as if the termination had been issued for the convenience of the AGENCY.

Termination for Default (Construction)

If the Contractor refuses or fails to prosecute the work or any separable part, with the diligence that will ensure its completion within the time specified in this contract or any extension or fails to complete the work within this time, or if the Contractor fails to comply with any other provision of this contract, AGENCY may terminate this contract for default. The AGENCY shall terminate by delivering to the Contractor a Notice of Termination specifying the nature of the default. In this event, the AGENCY may take over the work and complete it by contract or otherwise, and may take possession of and use any materials, appliances, and plant on the work site necessary for completing the work. The Contractor and its sureties shall be liable for any damage to the AGENCY resulting from the Contractor's refusal or failure to complete the work within specified time, whether or not the Contractor's right to proceed with the work is terminated. This liability includes any increased costs incurred by the AGENCY in completing the work.

The Contractor's right to proceed shall not be terminated nor shall the Contractor be charged with damages under this clause if:

1. The delay in completing the work arises from unforeseeable causes beyond the control and without the fault or negligence of the Contractor. Examples of such causes include: acts of God, acts of AGENCY, acts of another contractor in the performance of a contract with AGENCY, epidemics, quarantine restrictions, strikes, freight embargoes; and
2. The Contractor, within [10] days from the beginning of any delay, notifies AGENCY in writing of the causes of delay. If, in the judgment of AGENCY, the delay is excusable, the time for completing the work shall be extended. The judgment of AGENCY shall be final and conclusive for the parties, but subject to appeal under the Disputes clause(s) of this contract.

If, after termination of the Contractor's right to proceed, it is determined that the Contractor was not in default, or that the delay was excusable, the rights and obligations of the parties will be the same as if the termination had been issued for the convenience of AGENCY.

Termination for Convenience or Default (Architect and Engineering)

The AGENCY may terminate this contract in whole or in part, for the AGENCY's convenience or because of the failure of the Contractor to fulfill the contract obligations. The AGENCY shall terminate by delivering to the Contractor a Notice of Termination specifying the nature, extent, and effective date of the termination. Upon receipt of the notice, the Contractor shall (1) immediately discontinue all services affected (unless the notice directs otherwise), and (2) deliver to the AGENCY's Contracting Officer all data, drawings, specifications, reports, estimates, summaries, and other information and materials accumulated in performing this contract, whether completed or in process. AGENCY has a royalty-free, nonexclusive, and irrevocable license to reproduce, publish or otherwise use, all such data, drawings, specifications, reports, estimates, summaries, and other information and materials.

If the termination is for the convenience of the AGENCY, the AGENCY's Contracting Officer shall make an equitable adjustment in the contract price but shall allow no anticipated profit on unperformed services.

If the termination is for failure of the Contractor to fulfill the contract obligations, the AGENCY may complete the work by contract or otherwise and the Contractor shall be liable for any additional cost incurred by the AGENCY.

If, after termination for failure to fulfill contract obligations, it is determined that the Contractor was not in default, the rights and obligations of the parties shall be the same as if the termination had been issued for the convenience of AGENCY.

Termination for Convenience or Default (Cost-Type Contracts)

The AGENCY may terminate this contract, or any portion of it, by serving a Notice of Termination on the Contractor. The notice shall state whether the termination is for convenience of AGENCY or for the default of the Contractor. If the termination is for default, the notice shall state the manner in which the Contractor has failed to perform the requirements of the contract. The Contractor shall account for any property in its possession paid for from funds received from the AGENCY, or property supplied to the Contractor by the AGENCY. If the termination is for default, the AGENCY may fix the fee, if the contract provides for a fee, to be paid the Contractor in proportion to the value, if any, of work performed up to the time of termination. The Contractor shall promptly submit its termination claim to the AGENCY and the parties shall negotiate the termination settlement to be paid the Contractor.

If the termination is for the convenience of AGENCY, the Contractor shall be paid its contract close-out costs, and a fee, if the contract provided for payment of a fee, in proportion to the work performed up to the time of termination.

If, after serving a Notice of Termination for Default, the AGENCY determines that the Contractor

has an excusable reason for not performing, the AGENCY, after setting up a new work schedule, may allow the Contractor to continue work, or treat the termination as a Termination for Convenience.

VETERANS EMPLOYMENT

FTA Circular 4220.1F (Chapter IV) 49 USC §5325(K)

Applicability to Contracts The Veterans Employment provisions apply to all construction contracts.

Veterans Employment.

Recipients and subrecipients of Federal financial assistance under this chapter shall ensure that contractors working on a capital project funded using such assistance give a hiring preference, to the extent practicable, to veterans (as defined in section 2108 of title 5) who have the requisite skills and abilities to perform the construction work required under the contract. This subsection shall not be understood, construed or enforced in any manner that would require an employer to give preference to any veteran over any equally qualified applicant who is a member of any racial or ethnic minority, female, an individual with a disability, or former employee.

VIOLATION AND BREACH OF CONTRACT

>\$250,000

2 C.F.R. § 200.326

2 C.F.R. part 200, Appendix II (A)

Applicability to Contracts

All contracts in excess of the Simplified Acquisition Threshold (currently set at \$150,000) shall contain administrative, contractual, or legal remedies in instances where contractors violate or breach contract terms, and provide for such sanctions and penalties as appropriate.

Flow Down

The Violations and Breach of Contracts clause flow down to all third party contractors and their contracts at every tier.

Clauses Language

FTA does not prescribe the form or content of such provisions. The provisions developed will depend on the circumstances and the type of contract. Recipients should consult legal counsel in developing appropriate clauses. The following clauses are examples of provisions from various FTA third party contracts. Recipients can draw on these examples for inclusion in their federally funded procurements.

Rights and Remedies of the AGENCY

The AGENCY shall have the following rights in the event that the AGENCY deems the Contractor guilty of a breach of any term under the Contract.

1. The right to take over and complete the work or any part thereof as agency for and at the expense of the Contractor, either directly or through other contractors;
2. The right to cancel this Contract as to any or all of the work yet to be performed;
3. The right to specific performance, an injunction or any other appropriate equitable remedy; and
4. The right to money damages.

For purposes of this Contract, breach shall include [AGENCY to define].

Rights and Remedies of Contractor

Inasmuch as the Contractor can be adequately compensated by money damages for any breach of this Contract, which may be committed by the AGENCY, the Contractor expressly agrees that no default, act or omission of the AGENCY shall constitute a material breach of this Contract, entitling Contractor to cancel or rescind the Contract (unless the AGENCY directs Contractor to do so) or to suspend or abandon performance.

Remedies

Substantial failure of the Contractor to complete the Project in accordance with the terms of this Agreement will be a default of this Agreement. In the event of a default, the AGENCY will have all remedies in law and equity, including the right to specific performance, without further assistance, and the rights to termination or suspension as provided herein. The Contractor recognizes that in the event of a breach of this Agreement by the Contractor before the AGENCY takes action contemplated herein, the AGENCY will provide the Contractor with sixty (60) days written notice that the AGENCY considers that such a breach has occurred and will provide the Contractor a reasonable period of time to respond and to take necessary corrective action.

Disputes

- Example 1: Disputes arising in the performance of this Contract that are not resolved by agreement of the parties shall be decided in writing by the authorized representative of AGENCY's [title of employee]. This decision shall be final and conclusive unless within [10] days from the date of receipt of its copy, the Contractor mails or otherwise furnishes a written appeal to the [title of employee]. In connection with any such appeal, the Contractor shall be afforded an opportunity to be heard and to offer evidence in support of its position. The decision of the [title of employee] shall be binding upon the Contractor and the Contractor shall abide by the decision.
- Example 2: The AGENCY and the Contractor intend to resolve all disputes under this Agreement to the best of their abilities in an informal manner. To accomplish this end, the parties will use an Alternative Dispute Resolution process to resolve disputes in a manner designed to avoid litigation. In general, the parties contemplate that the Alternative Dispute Resolution process will include, at a minimum, an attempt to resolve disputes through communications between their staffs, and, if resolution is not reached at that level, a procedure for review and action on such disputes by appropriate management level officials within the AGENCY and the Contractor's organization.

In the event that a resolution of the dispute is not mutually agreed upon, the parties can agree to mediate the dispute or proceed with litigation. Notwithstanding any provision of this section, or any other provision of this Contract, it is expressly agreed and understood that any court proceeding arising out of a dispute under the Contract shall be heard by a Court de novo and the court shall not be limited in such proceeding to the issue of whether the Authority acted in an arbitrary, capricious or grossly erroneous manner.

Pending final settlement of any dispute, the parties shall proceed diligently with the performance of the Contract, and in accordance with the AGENCY's direction or decisions made thereof.

Performance during Dispute

Unless otherwise directed by AGENCY, Contractor shall continue performance under this Contract while matters in dispute are being resolved.

Claims for Damages

Should either party to the Contract suffer injury or damage to person or property because of any act or omission of the party or of any of its employees, agents or others for whose acts it is legally liable, a claim for damages therefore shall be made in writing to such other party within a reasonable time after the first observance of such injury or damage.

Remedies

Unless this Contract provides otherwise, all claims, counterclaims, disputes and other matters in question between the AGENCY and the Contractor arising out of or relating to this agreement or its breach will be decided by arbitration if the parties mutually agree, or in a court of competent jurisdiction within the State in which the AGENCY is located.

Rights and Remedies

The duties and obligations imposed by the Contract documents and the rights and remedies available thereunder shall be in addition to and not a limitation of any duties, obligations, rights and remedies otherwise imposed or available by law. No action or failure to act by the AGENCY or Contractor shall constitute a waiver of any right or duty afforded any of them under the Contract, nor shall any such action or failure to act constitute an approval of or acquiescence in any breach thereunder, except as may be specifically agreed in writing.

Appendix A

**COMPLIANCE CERTIFICATION WITH FEDERAL REQUIREMENTS
FTA Clauses and Provisions for Construction**

Contained in the documents below are contract clauses and provisions required by the Federal Transit Administration (FTA) and the Utah Department of Transportation for federally funded projects for this type of procurement.

The term AGENCY in these clauses and provisions refer to the Subrecipient of the FTA funds, who is the transit agency that is administering the project.

AGENCY: Park City Municipal Corporation (PCMC)

The Contractor hereby certifies that it will comply with all requirements listed herein.

Contractor: _____

Name: _____ Title: _____

Signature: _____ Date: _____

ACCESS TO RECORDS AND REPORTS

49 U.S.C. § 5325(g)

2 C.F.R. § 200.333

49 C.F.R. part 633

Applicability to Contracts

The record keeping and access requirements apply to all contracts funded in whole or in part with FTA funds. Under 49 U.S.C. § 5325(g), FTA has the right to examine and inspect all records, documents, and papers, including contracts, related to any FTA project financed with Federal assistance authorized by 49 U.S.C. Chapter 53.

Flow Down

The record keeping and access requirements extend to all third party contractors and their contracts at every tier and subrecipients and their subcontracts at every tier.

Clause Language

Recipients can draw on the following language for inclusion in their federally funded procurements.

Access to Records and Reports

- a. **Record Retention**. The Contractor will retain, and will require its subcontractors of all tiers to retain, complete and readily accessible records related in whole or in part to the contract, including, but not limited to, data, documents, reports, statistics, sub-agreements, leases, subcontracts, arrangements, other third party agreements of any type, and supporting materials related to those records.
- b. **Retention Period**. The Contractor agrees to comply with the record retention requirements in accordance with 2 C.F.R. § 200.333. The Contractor shall maintain all books, records, accounts and reports required under this Contract for a period of at not less than three (3) years after the date of termination or expiration of this Contract, except in the event of litigation or settlement of claims arising from the performance of this Contract, in which case records shall be maintained until the disposition of all such litigation, appeals, claims or exceptions related thereto.
- c. **Access to Records**. The Contractor agrees to provide sufficient access to FTA and its contractors to inspect and audit records and information related to performance of this contract as reasonably may be required.
- d. **Access to the Sites of Performance**. The Contractor agrees to permit FTA and its contractors access to the sites of performance under this contract as reasonably may be required.

ADA ACCESS
49 USC 531 (d)

Applicability to Contracts

The ADA Access Requirements apply to all contracts.

Applicability to Micro-Purchases

Micro-purchases are defined as those purchases under \$10,000. These requirements do not apply to micro-purchases; except for construction contracts over \$2,000.

Flow Down Requirement

The ADA Access Requirements flow down to all third party contractors and their contracts at every tier.

Clause Language

ADA Access. The Americans with Disabilities Act of 1990 (ADA) prohibits discrimination and ensures equal opportunity and access for persons with disabilities.

Access Requirements for Persons with Disabilities

Contractor shall comply with 49 USC 5301(d), stating Federal policy that the elderly and persons with disabilities have the same rights as other persons to use mass transportation services and facilities and that special efforts shall be made in planning and designing those services and facilities to implement that policy. Contractor shall also comply with all applicable requirements of Sec. 504 of the Rehabilitation Act (1973), as amended, 29 USC 794, which prohibits discrimination on the basis of handicaps, and the Americans with Disabilities Act of 1990 (ADA), as amended, 42 USC 12101 et seq., which requires that accessible facilities and services be made available to persons with disabilities, including any subsequent amendments thereto.

BONDING REQUIREMENTS

>\$250,000

(including ferry vessels)

2 C.F.R. § 200.325

31 C.F.R. part 223

Applicability to Contracts

Bonds are required for all construction or facility improvement contracts and subcontracts exceeding the simplified acquisition threshold. FTA may accept the bonding policy and requirements of the recipient if FTA has determined that the Federal interest is adequately protected. If such a determination has not been made, the following minimum requirements apply:

- a. A bid guarantee from each bidder equivalent to five percent of the bid price. The “bid guarantee” must consist of a firm commitment such as a bid bond, certified check, or other negotiable instrument accompanying a bid as assurance that the bidder will, upon acceptance of the bid, execute such contractual documents as may be required within the time specified.
- b. A performance bond on the part of the contractor for 100 percent of the contract price. A “performance bond” is one executed in connection with a contract to secure fulfillment of all the contractor’s obligations under such contract.
- c. A payment bond on the part of the contractor for 100 percent of the contract price. A “payment bond” is one executed in connection with a contract to assure payment as required by law of all persons supplying labor and material in the execution of the work provided for in the contract.

Flow Down

These requirements extend to all third party contractors and their contracts at every tier and subrecipients and their subcontracts at every tier that exceed the simplified acquisition threshold.

Clauses Language

Recipients can draw on the following language for inclusion in their federally funded procurements.

Bond Requirements

Bid Guarantee

Bidders shall furnish a bid guaranty in the form of a bid bond, or certified treasurer’s or cashier’s check issued by a responsible bank or trust company, made payable to the RECIPIENT. The amount of such guaranty shall be equal to \$\$\$\$ or X% of the total bid price.

In submitting this bid, it is understood and agreed by bidder that the RECIPIENT reserves the right to reject any and all bids, or part of any bid, and it is agreed that the Bid may not be withdrawn for a period of [90] days subsequent to the opening of bids, without the written consent of RECIPIENT.

It is also understood and agreed that if the undersigned bidder should withdraw any part or all of his bid within [90] days after the bid opening without the written consent of the RECIPIENT, or refuse or be unable to enter into this Contract as provided above, or refuse or be unable to furnish adequate and acceptable Performance and Payment Bonds, or refuse or be unable to furnish adequate and acceptable insurance, as provided above, it shall forfeit its bid guaranty to the extent RECIPIENT'S damages occasioned by such withdrawal, or refusal, or inability to enter into an agreement, or provide adequate security thereof.

It is further understood and agreed that to the extent the defaulting bidder's bid guaranty shall prove inadequate to fully recompense RECIPIENT for the damages occasioned by default, then the undersigned bidder agrees to indemnify RECIPIENT and pay over to RECIPIENT the difference between the bid guarantee and RECIPIENT'S total damages so as to make RECIPIENT whole.

The undersigned understands that any material alteration of any of the above or any of the material contained herein, other than that requested will render the bid unresponsive.

Performance Guarantee

A Performance Guarantee in the amount of **100%** of the Contract value is required by the Recipient to ensure faithful performance of the Contract. Either a Performance Bond or an Irrevocable Stand-By Letter of Credit shall be provided by the Contractor and shall remain in full force for the term of the Agreement. The successful Bidder shall certify that it will provide the requisite Performance Guarantee to the RECIPIENT within ten (10) business days from Contract execution. The RECIPIENT requires all Performance Bonds to be provided by a fully qualified surety company acceptable to the RECIPIENT and listed as a company currently authorized under 31 C.F.R. part 22 as possessing a Certificate of Authority as described hereunder. RECIPIENT may require additional performance bond protection when the contract price is increased. The increase in protection shall generally equal 100 percent of the increase in contract price. The RECIPIENT may secure additional protection by directing the Contractor to increase the amount of the existing bond or to obtain an additional bond.

If the Bidder chooses to provide a Letter of Credit as its Performance Guarantee, the Bidder shall furnish with its bid, certification that an Irrevocable Stand-By Letter of Credit will be furnished should the Bidder become the successful Contractor. The Bidder shall also provide a statement from the banking institution certifying that an Irrevocable Stand-By Letter of Credit for the action will be provided if the Contract is awarded to the Bidder. The Irrevocable Stand-By Letter of Credit will only be accepted by the RECIPIENT if:

1. A bank in good standing issues it. The RECIPIENT will not accept a Letter of Credit from an entity other than a bank.
2. It is in writing and signed by the issuing bank.
3. It conspicuously states that it is an irrevocable, non-transferable, "standby" Letter of Credit.
4. The RECIPIENT is identified as the Beneficiary.
5. It is in an amount equal to **100%** of the Contract value. This amount must be in U.S. dollars.
6. The effective date of the Letter of Credit is the same as the effective date of the Contract
7. The expiration date of the Letter of Credit coincides with the term of this Agreement.
8. It indicates that it is being issued in order to support the obligation of the Contractor to perform under the Contract. It must specifically reference the Contract between the RECIPIENT and the Contractor the work stipulated herein.

The issuing bank's obligation to pay will arise upon the presentation of the original Letter of Credit and a certificate and draft (similar to the attached forms contained in Sections X and Y) to the issuing bank's representative at a location and time to be determined by the parties. This documentation will indicate that the Contractor is in default under the Contract.

Payment Bonds

A Labor and Materials Payment Bond equal to the full value of the contract must be furnished by the contractor to Recipient as security for payment by the Contractor and subcontractors for labor, materials, and rental of equipment. The bond may be issued by a fully qualified surety company acceptable to (Recipient) and listed as a company currently authorized under 31 C.F.R. part 223 as possessing a Certificate of Authority as described thereunder.

Sample Bond Certifications

Performance Guarantee Certification

The undersigned hereby certifies that the Bidder shall provide a Performance Guarantee in accordance with the Specifications.

Designate below which form of Performance Guarantee shall be provided:

_____ Performance
Bond

_____ Irrevocable Stand-By-Letter of
Credit

BIDDER'S
NAME: _____

AUTHORIZED
SIGNATURE: _____

TITLE: _____

—

DATE: _____

—

Performance Bond

KNOW ALL MEN BY THESE PRESENTS: that

(Insert full name and address and legal title of Contractor) as Principal, hereinafter called Contractor, and

_____ (Insert full name and address or legal title of Surety) as Surety, hereinafter called Surety, are held and firmly bound unto RECIPIENT as Obligee, hereinafter called Authority, in the amount of _ Dollars (\$) for the payment whereof Contractor and Surety bind themselves, their heirs, executors, administrators, successors and assigns, jointly and severally, firmly by these presents.

WHEREAS, Contractor has by written agreement dated __, 20__ , entered into a contract with the RECIPIENT for Contract No. _____, which contract is by reference made a part hereof, and is hereinafter referred to as the Contract.

NOW, THEREFORE, THE CONDITION OF THIS OBLIGATION is such that, if Contractor shall promptly and faithfully perform said Contract, then this obligation shall be null and void; otherwise it shall remain in full force and effect.

The Surety hereby waives notice of any alteration or extension of time made by the RECIPIENT.

Whenever Contractor shall be, and is declared by the RECIPIENT to be in default under the Contract, the RECIPIENT having performed RECIPIENT'S obligations thereunder, the Surety may promptly remedy the default, or shall promptly

1. Complete the Contract in accordance with its terms and conditions, or
2. Obtain a bid or bids for completing the Contract in accordance with its terms and conditions, and upon determination by Surety of the lowest responsible bidder, or, if the RECIPIENT elects, upon determination by the RECIPIENT and the Surety jointly of the lowest responsible bidder, arrange for a contract between such bidder and the Authority, and make available as Work progresses (even though there should be a default or a succession of defaults under the contract or contracts of completion arranged under this paragraph) sufficient funds to pay the cost of completion less the balance of the contract price; but not exceeding, the amount set forth in the first paragraph hereof. The term "balance of the contract price," as used in this paragraph, shall mean the total amount payable by the RECIPIENT to Contractor under the Contract and any amendments thereto, less the amount properly paid by the RECIPIENT to Contractor.

Any suit under this bond must be instituted before the expiration of two (2) years from the date on which final payment under the Contract falls due.

No right of action shall accrue on this bond to or for the use of any person or corporation other than the RECIPIENT or the heirs, executors, administrators or successors of the RECIPIENT.

Signed and sealed this _____ day of _____ 20__ .

WITNESS

PRINCIPAL

_____(SEAL)

_____(Title)

WITNESS

SURETY

_____(SEAL)

_____(Title)

Attach hereto proof of authority of officers or agents to sign bond.

Irrevocable Stand-By Letter Of Credit Certificate

The undersigned states that he/she is _____ of the
(Title)

_____(The "Beneficiary") and hereby
(Name of Beneficiary)

Certifies on behalf of the Beneficiary to _____(the "Bank"),
with
(Name of Issuing Bank)

Reference to Irrevocable Standby Letter of Credit No. _____ Issued by the
Bank (the "Letter of Credit"), that:

1. The undersigned is duly authorized to execute and deliver this certificate on behalf of the Beneficiary.
2. The Beneficiary is making a drawing under the Letter of Credit.
3. An Event of Default has occurred under Contract No. _____
4. The amount of the draft presented with this certificate does not exceed the total maximum amount drawable today under the Letter of Credit as provided therein.

IN WITNESS WHEREOF, this certificate is executed this _____ day of _____, 20__ .

(NAME OF BENEFICIARY)

By: _____

Its: _____

Bank Draft

FOR VALUE RECEIVED

Pay on presentment to _____ the sum of
_____ Dollars (\$)
(Name of Beneficiary)

Charge the Account of _____ Irrevocably Standby Letter
of _____
(Name of Issuing Bank)

Credit No. _____ Dated: 20 _____.

To _____
(Name of Issuing Bank)

NAME OF BENEFICIARY

By _____

Its _____

BUY AMERICA REQUIREMENTS
>\$150,000

As of Feb 2011 FTA has not adopted the FAR 2.101 \$150,000 standard.

49 U.S.C. 5323(j)

49 C.F.R. part 661

Applicability to Contracts

FTA's Buy America law and regulations apply to projects that involve the purchase of more than \$150,000 of iron, steel, manufactured goods, or rolling stock to be delivered to the recipient to be used in an FTA assisted project. FTA cautions that its Buy America regulations are complex. Recipients can obtain detailed information on FTA's Buy America regulation at: [Buy America | FTA \(dot.gov\)](#)

Flow Down

The Buy America requirements flow down from FTA recipients and subrecipients to first tier contractors, who are responsible for ensuring that lower tier contractors and subcontractors are in compliance.

Clause Language

The Buy America regulation at 49 C.F.R. § 661.13 requires notification of the Buy America requirements in a recipients' bid or request for proposal for FTA funded contracts. Recipients can draw on the following language for inclusion in their federally funded procurements. Note that recipients are responsible for including the correct Buy America certification based on what they are acquiring. Recipients should not include both the rolling stock and steel, iron, or manufactured products certificates in the documents unless acquiring both in the same procurement.

Buy America

The contractor agrees to comply with 49 U.S.C. 5323(j) and 49 C.F.R. part 661, which provide that Federal funds may not be obligated unless all steel, iron, and manufactured products used in FTA funded projects are produced in the United States, unless a waiver has been granted by FTA or the product is subject to a general waiver. General waivers are listed in 49 C.F.R. § 661.7. Separate Requirements for rolling stock are set out at 49 U.S.C. 5323(j)(2)(C) and 49 C.F.R. § 661.11.

The [bidder or offeror] must submit to [Recipient] the appropriate Buy America certification below with its [bid or offer]. Bids or offers that are not accompanied by a completed Buy America certification will be rejected as nonresponsive.

In accordance with 49 C.F.R. § 661.6, for the procurement of steel, iron or manufactured products, use the certifications below.

Certificate of Compliance with Buy America Requirements

The bidder or offeror hereby certifies that it will comply with the requirements of 49 U.S.C.

5323(j)(1), and the applicable regulations in 49 C.F.R. part 661.

Date: _____

—

Signature: _____

—

Company:

Name: _____

—

Title: _____

—

Certificate of Non-Compliance with Buy America Requirements

The bidder or offeror hereby certifies that it cannot comply with the requirements of 49 U.S.C. 5323(j), but it may qualify for an exception to the requirement pursuant to 49 U.S.C. 5323(j)(2), as amended, and the applicable regulations in 49 C.F.R. § 661.7.

Date: _____

Signature:

Company: _____

Name: _____

Title: _____

In accordance with 49 C.F.R. § 661.12, for the procurement of rolling stock (including traincontrol, communication, and traction power equipment) use the following certifications:

Certificate of Compliance with Buy America Rolling Stock Requirements

The bidder or offeror hereby certifies that it will comply with the requirements of 49 U.S.C.

5323(j), and the applicable regulations of 49 C.F.R. § 661.11.

Date: _____

Signature: _____

Company: _____

Name: _____

Title: _____

Certificate of Non-Compliance with Buy America Rolling Stock Requirements

The bidder or offeror hereby certifies that it cannot comply with the requirements of 49 U.S.C. 5323(j), but may qualify for an exception to the requirement consistent with 49 U.S.C. 5323(j)(2)(C), and the applicable regulations in 49 C.F.R. § 661.7.

Date: _____

Signature: _____

Company: _____

Name: _____

Title: _____

CARGO PREFERENCE REQUIREMENTS
Involving property that may be transported by ocean vessel.

46 U.S.C. § 55305
46 C.F.R. part 381

Applicability to Contracts

The Cargo Preference Act of 1954 requirements applies to all contracts involving equipment, materials, or commodities that may be transported by ocean vessels.

Flow Down

The Cargo Preference requirements apply to all contracts involved with the transport of equipment, material, or commodities by ocean vessel.

Clause Language

The Maritime Administration (MARAD) regulations at 46 C.F.R. § 381.7 contain suggested contract clauses. Recipients can draw on the following language for inclusion in their federally funded procurements.

Cargo Preference - Use of United States-Flag Vessels

The contractor agrees:

1. to use privately owned United States-Flag commercial vessels to ship at least 50 percent of the gross tonnage (computed separately for dry bulk carriers, dry cargo liners, and tankers) involved, whenever shipping any equipment, material, or commodities pursuant to the underlying contract to the extent such vessels are available at fair and reasonable rates for United States-Flag commercial vessels;
2. to furnish within 20 working days following the date of loading for shipments originating within the United States or within 30 working days following the date of loading for shipments originating outside the United States, a legible copy of a rated, "on-board" commercial ocean bill-of-lading in English for each shipment of cargo described in the preceding paragraph to the Division of National Cargo, Office of Market Development, Maritime Administration, Washington, DC 20590 and to the FTA recipient (through the contractor in the case of a subcontractor's bill-of-lading.); and
3. to include these requirements in all subcontracts issued pursuant to this contract when the subcontract may involve the transport of equipment, material, or commodities by ocean vessel.

CIVIL RIGHTS LAWS AND REGULATIONS

Applicability to Contracts

The following Federal Civil Rights laws and regulations apply to all contracts.

1. Federal Equal Employment Opportunity (EEO) Requirements. These include, but are not limited to:

a. Nondiscrimination in Federal Public Transportation Programs. 49 U.S.C. § 5332, covering projects, programs, and activities financed under 49 U.S.C. Chapter 53, prohibits discrimination on the basis of race, color, religion, national origin, sex (including sexual orientation and gender identity), disability, or age, and prohibits discrimination in employment or business opportunity.

b. Prohibition against Employment Discrimination. Title VII of the Civil Rights Act of 1964, as amended, 42 U.S.C. § 2000e, and Executive Order No. 11246, "Equal Employment Opportunity," September 24, 1965, as amended, prohibit discrimination in employment on the basis of race, color, religion, sex, or national origin.

2. Nondiscrimination on the Basis of Sex. Title IX of the Education Amendments of 1972, as amended, 20 U.S.C. § 1681 et seq. and implementing Federal regulations, "Nondiscrimination on the Basis of Sex in Education Programs or Activities Receiving Federal Financial Assistance," 49 C.F.R. part 25 prohibit discrimination on the basis of sex.

3. Nondiscrimination on the Basis of Age. The "Age Discrimination Act of 1975," as amended, 42 U.S.C. § 6101 et seq., and Department of Health and Human Services implementing regulations, "Nondiscrimination on the Basis of Age in Programs or Activities Receiving Federal Financial Assistance," 45 C.F.R. part 90, prohibit discrimination by participants in federally assisted programs against individuals on the basis of age. The Age Discrimination in Employment Act (ADEA), 29 U.S.C. § 621 et seq., and Equal Employment Opportunity Commission (EEOC) implementing regulations, "Age Discrimination in Employment Act," 29 C.F.R. part 1625, also prohibit employment discrimination against individuals age 40 and over on the basis of age.

4. Federal Protections for Individuals with Disabilities. The Americans with Disabilities Act of 1990, as amended (ADA), 42 U.S.C. § 12101 et seq., prohibits discrimination against qualified individuals with disabilities in programs, activities, and services, and imposes specific requirements on public and private entities. Third party contractors must comply with their responsibilities under Titles I, II, III, IV, and V of the ADA in employment, public services, public accommodations, telecommunications, and other provisions, many of which are subject to regulations issued by other Federal agencies.

Flow Down

The Civil Rights requirements flow down to all third party contractors and their contracts at every tier.

Clause Language

Every federally funded contract must include an Equal Opportunity clause. Recipients can draw on the following language for inclusion in their federally funded procurements.

Civil Rights and Equal Opportunity

The AGENCY is an Equal Opportunity Employer. As such, the AGENCY agrees to comply with all applicable Federal civil rights laws and implementing regulations. Apart from inconsistent requirements imposed by Federal laws or regulations, the AGENCY agrees to comply with the requirements of 49 U.S.C. § 5323(h) (3) by not using any Federal assistance awarded by FTA to support procurements using exclusionary or discriminatory specifications.

Under this Agreement, the Contractor shall at all times comply with the following requirements and shall include these requirements in each subcontract entered into as part thereof.

- 1. Nondiscrimination.** In accordance with Federal transit law at 49 U.S.C. § 5332, the Contractor agrees that it will not discriminate against any employee or applicant for employment because of race, color, religion, national origin, sex, disability, or age. In addition, the Contractor agrees to comply with applicable Federal implementing regulations and other implementing requirements FTA may issue.
- 2. Race, Color, Religion, National Origin, Sex.** In accordance with Title VII of the Civil Rights Act, as amended, 42 U.S.C. § 2000e et seq., and Federal transit laws at 49 U.S.C. § 5332, the Contractor agrees to comply with all applicable equal employment opportunity requirements of U.S. Department of Labor (U.S. DOL) regulations, "Office of Federal Contract Compliance Programs, Equal Employment Opportunity, Department of Labor," 41 C.F.R. chapter 60, and Executive Order No. 11246, "Equal Employment Opportunity in Federal Employment," September 24, 1965, 42 U.S.C. § 2000e note, as amended by any later Executive Order that amends or supersedes it, referenced in 42U.S.C. § 2000e note. The Contractor agrees to take affirmative action to ensure that applicants are employed, and that employees are treated during employment, without regard to their race, color, religion, national origin, or sex (including sexual orientation and gender identity). Such action shall include, but not be limited to, the following: employment, promotion, demotion or transfer, recruitment or recruitment advertising, layoff or termination; rates of pay or other forms of compensation; and selection for training, including apprenticeship. In addition, the Contractor agrees to comply with any implementing requirements FTA may issue.
- 3. Age.** In accordance with the Age Discrimination in Employment Act, 29 U.S.C. §§ 621- 634, U.S. Equal Employment Opportunity Commission (U.S. EEOC) regulations, "Age Discrimination in Employment Act," 29 C.F.R. part 1625, the Age Discrimination Act of 1975, as amended, 42 U.S.C. § 6101 et seq., U.S. Health and Human Services regulations, "Nondiscrimination on the Basis of Age in Programs or Activities Receiving Federal Financial Assistance," 45 C.F.R. part 90, and Federal transit law at 49 U.S.C. § 5332, the Contractor agrees to refrain from discrimination against present and prospective employees for reason of age. In addition, the Contractor agrees to comply with any implementing requirements FTA may issue.

4. **Disabilities.** In accordance with section 504 of the Rehabilitation Act of 1973, as amended, 29 U.S.C. § 794, the Americans with Disabilities Act of 1990, as amended, 42U.S.C. § 12101 et seq., the Architectural Barriers Act of 1968, as amended, 42 U.S.C. §4151 et seq., and Federal transit law at 49 U.S.C. § 5332, the Contractor agrees that it will not discriminate against individuals on the basis of disability. In addition, the Contractor agrees to comply with any implementing requirements FTA may issue.

Title VI Attachments A and E

Title VI of the Civil Rights Act of 1964 – Non – Discrimination Notice; Attachment A NON-DISCRIMINATION NOTICE

In accordance with Title VI of the Civil Rights Act of 1964, 78 Stat. 252, 42 U.S.C 2000d to 2000d-4 and the Title 49, Code of Federal Regulations. The text below, in its entirety, is in all contracts entered into by the Department. All of the text except the final section, entitled “Incorporation of Provisions,” should be included in any contract entered into by any the Department contractor.

During the performance of this contract, for itself, its assignees and successors in interest (hereinafter referred to as the “contractor”) agrees as follows:

A. COMPLIANCE WITH TITLE VI OF THE CIVIL RIGHTS ACT OF 1964 FOR FEDERAL-AID CONTRACTS

1. **Compliance with Regulations:** The contractor shall comply with the Regulation relative to nondiscrimination in Federally-assisted programs of the Department of Transportation (hereinafter, “DOT”) Title 49, Code of Federal Regulations, Part 21, as they may be amended from time to time, (hereinafter referred to as Regulations), which are herein incorporated by reference and made a part of this contract.
2. **Nondiscrimination:** The Contractor, with regard to the work performed by it during the contract, shall not discriminate on the grounds of race, color, sex, age, disability, income status, or national origin in the selection and retention of subcontractors, including procurements of materials and leases of equipment. The contractor shall not participate either directly or indirectly in the discrimination prohibited by section 21.5 of the Regulations, including employment practices when the contract covers a program set forth in Appendix B of the Regulations.
3. **Solicitations for Subcontractors, Including Procurements of Materials and Equipment:** In all solicitations either by competitive bidding or negotiation made by the contractor for work to be performed under a subcontract, including procurements of materials or leases of equipment, each potential subcontractor or supplier shall be notified by the contractor of the contractor’s obligations under this contract and the Regulations relative to nondiscrimination on the grounds of race, color, sex, age, disability, income status, or national origin.

4. Information and Reports: The contractor shall provide all information and reports required by the Regulations or directives issued pursuant thereto, and shall permit access to its books, records, accounts, other sources of information, and its facilities as may be determined by the (Recipient) or the (Name of Appropriate Administration) to be pertinent to ascertain compliance with such Regulations, orders and instructions. Where any information required of a contractor is in the exclusive possession of another who fails or refuses to furnish this information the contractor shall so certify to the (Recipient), or the (Name of Appropriate Administration) as appropriate, and shall set forth what efforts it has made to obtain the information.
5. Sanctions for Noncompliance: In the event of the contractor's noncompliance with the nondiscrimination provisions of this contract, the (Recipient) shall impose such contract sanctions as it or the (Name of Appropriate Administration) may determine to be appropriate, including, but not limited to:
 - a. Withholding of payments to the contractor under the contract until the contractor complies, and/or
 - b. Cancellation, termination or suspension of the contract, in whole or in part.
6. Incorporation of Provisions: The contractor shall include the provisions of paragraphs (1) through (6) in every subcontract, including procurements of materials and leases of equipment, unless exempt by the Regulations, or directives issued pursuant thereto.

The contractor shall take such action with respect to any subcontractor procurement as the (Recipient) or the (Name of Appropriate Administration) may direct as a means of enforcing such provisions including sanctions for noncompliance: Provided, however, that, in the event a contractor becomes involved in, or is threatened with litigation with a subcontractor or supplier as a result of such direction, the contractor may request the (Recipient) to enter into such litigation to protect the interests of the (Recipient), and, in addition, the contractor may request the United States to enter into such litigation to protect the interests of the United States.

Title VI of the Civil Rights Act of 1964 – Non – Discrimination Notice: Attachment E

During the performance of this contract, the contractor, for itself, its assignees, and successors in interest (hereinafter referred to as the "contractor") agrees to comply with the following non-discrimination statutes and authorities; including but not limited to:

Pertinent Non-Discrimination Authorities:

Title VI of the Civil Rights Act of 1964 (42 U.S.C. § 2000d et seq., 78 stat. 252), (prohibits discrimination on the basis of race, color, national origin); and 49 CFR Part 21.

The Uniform Relocation Assistance and Real Property Acquisition Policies Act of 1970, (42 U.S.C. § 460 I), (prohibits unfair treatment of persons displaced or whose property has been acquired because of Federal or Federal-aid programs and projects);

Federal-Aid Highway Act of 1973, (23 U.S.C. § 324 et seq.), (prohibits discrimination on the basis of sex);

Section 504 of the Rehabilitation Act of 1973, (29 U.S.C. § 794 et seq.), as amended, (prohibits discrimination on the basis of disability); and 49 CFR Part 27;

The Age Discrimination Act of 1975, as amended, (42 U.S.C. § 610 et seq.), (prohibits discrimination on the basis of age);

Airport and Airway Improvement Act of 1982, (49 USC § 47 I, Section 47123), as amended, (prohibits discrimination based on race, creed, color, national origin, or sex);

The Civil Rights Restoration Act of 1987, (PL 100-209), (Broadened the scope, coverage and applicability of Title VI of the Civil Rights Act of 1964, The Age Discrimination Act of 1975 and Section 504 of the Rehabilitation Act of 1973, by expanding the definition of the terms "programs or activities" to include all of the programs or activities of the Federal-aid recipients, sub-recipients and contractors, whether such programs or activities are Federally funded or not);

Titles II and III of the Americans with Disabilities Act, which prohibit discrimination on the basis of disability in the operation of public entities, public and private transportation systems, places of public accommodation, and certain testing entities (42 U.S.C. §§ 12131 - 12189) as implemented by Department of Transportation regulations at 49 C.F.R. parts 37 and 38;

The Federal Aviation Administration's Non-discrimination statute (49 U.S.C. §47123) (prohibits discrimination on the basis of race, color, national origin, and sex);

Executive Order 12898, Federal Actions to Address Environmental Justice in Minority Populations and Low-income Populations, which ensures discrimination against minority populations by discouraging programs, policies, and activities with disproportionately high and adverse human health or environmental effects on minority and low-income populations;

Executive Order 13166, Improving Access to Services for Persons with Limited English Proficiency, and resulting agency guidance, national origin discrimination includes discrimination because of limited English proficiency (LEP). To ensure compliance with Title VI, you must take reasonable steps to ensure that LEP persons have meaningful access to your programs (70 Fed. Reg. at 74087 to 74100);

Title IX of the Education Amendments of 1972, as amended, which prohibits you from discriminating because of sex in education programs or activities (20 U.S.C. 1681 et seq).

CIVIL RIGHTS DISADVANTAGED BUSINESS ENTERPRISE (DBE)

49 C.F.R. part 26

Background and Applicability

The Disadvantaged Business Enterprise (DBE) program applies to FTA recipients receiving planning, capital and/or operating assistance that will award prime contracts (excluding transit vehicle purchases) exceeding \$250,000 in FTA funds in a Federal fiscal year. All FTA recipients above this threshold must submit a DBE program and overall triennial goal for DBE participation. The overall goal reflects the anticipated amount of DBE participation on DOT-assisted contracts. As part of its DBE program, FTA recipients must require that each transit vehicle manufacturer (TVM), as a condition of being authorized to bid or propose on FTA assisted transit vehicle procurements, certify that it has complied with the requirements of 49 C.F.R. § 26.49. Only those transit vehicle manufacturers listed on FTA's certified list of Transit Vehicle Manufacturers, or that have submitted a goal methodology to FTA that has been approved or has not been disapproved at the time of solicitation, are eligible to bid.

FTA recipients must meet the maximum feasible portion of their overall goal using race-neutral methods. Where appropriate, however, recipients are responsible for establishing DBE contract goals on individual DOT-assisted contracts. FTA recipients may use contract goals only on those DOT-assisted contracts that have subcontracting responsibilities. See 49 C.F.R. § 26.51(e). Furthermore, while FTA recipients are not required to set a contract goal on every DOT-assisted contract, they are responsible for achieving their overall program goals by administering their DBE program in good faith.

FTA recipients and third party contractors can obtain information about the DBE program at the following website locations:

[Federal Transit Administration website Disadvantaged Business Enterprise page click here](#)

[Department of Transportation website Disadvantaged Business Enterprise Program click here](#)

Flow Down

The DBE contracting requirements flow down to all third party contractors and their contracts at every tier. It is the recipient's and prime contractor's responsibility to ensure the DBE requirements are applied across the board to all subrecipients/contractors/subcontractors. Should a subcontractor fail to comply with the DBE regulations, FTA would look to the recipient to make sure it intervenes to monitor compliance. The onus for compliance is on the recipient.

Clause Language

For all DOT-assisted contracts, each FTA recipient must include assurances that third party contractors will comply with the DBE program requirements of 49 C.F.R. part 26, when applicable. The following contract clause is required in all DOT-assisted prime and subcontracts:

The contractor, subrecipient or subcontractor shall not discriminate on the basis of race, color, national origin, or sex in the performance of this contract. The contractor shall carry out applicable requirements of 49 C.F.R. part 26 in the award and administration of DOT-assisted contracts. Failure by the contractor to carry out these requirements is a material breach of this

contract, which may result in the termination of this contract or such other remedy as the recipient deems appropriate, which may include, but is not limited to:

- (1) Withholding monthly progress payments;
- (2) Assessing sanctions;
- (3) Liquidated damages; and/or
- (4) Disqualifying the contractor from future bidding as non-responsible. 49 C.F.R. § 26.13(b).

Further, recipients must establish a contract clause to require prime contractors to pay subcontractors for satisfactory performance of their contracts no later than 30 days from receipt of each payment the recipient makes to the prime contractor. 49 C.F.R. § 26.29(a). Finally, for contracts with defined DBE contract goals, each FTA recipient must include in each prime contract a provision stating that the contractor shall utilize the specific DBEs listed unless the contractor obtains the recipient's written consent; and that, unless the recipient's consent is provided, the contractor shall not be entitled to any payment for work or material unless it is performed or supplied by the listed DBE. 49 C.F.R. § 26.53(f) (1).

As an additional resource, recipients can draw on the following language for inclusion in their federally funded procurements.

Overview

It is the policy of the AGENCY and the United States Department of Transportation ("DOT") that Disadvantaged Business Enterprises ("DBE's"), as defined herein and in the Federal regulations published at 49 C.F.R. part 26, shall have an equal opportunity to participate in DOT-assisted contracts. It is also the policy of the AGENCY to:

1. Ensure nondiscrimination in the award and administration of DOT-assisted contracts;
2. Create a level playing field on which DBE's can compete fairly for DOT-assisted contracts;
3. Ensure that the DBE program is narrowly tailored in accordance with applicable law;
4. Ensure that only firms that fully meet 49 C.F.R. part 26 eligibility standards are permitted to participate as DBE's;
5. Help remove barriers to the participation of DBEs in DOT assisted contracts;
6. To promote the use of DBEs in all types of federally assisted contracts and procurement activities; and
7. Assist in the development of firms that can compete successfully in the marketplace outside the DBE program.

This Contract is subject to 49 C.F.R. part 26. Therefore, the Contractor must satisfy the requirements for DBE participation as set forth herein. These requirements are in addition to all

other equal opportunity employment requirements of this Contract. The AGENCY shall make all determinations with regard to whether or not a Bidder/Offeror is in compliance with the requirements stated herein. In assessing compliance, the AGENCY may consider during its review of the Bidder/Offeror's submission package, the Bidder/Offeror's documented history of non-compliance with DBE requirements on previous contracts with the AGENCY.

Contract Assurance

The Contractor, subrecipient or subcontractor shall not discriminate on the basis of race, color, national origin, or sex in the performance of this Contract. The Contractor shall carry out applicable requirements of 49 C.F.R. part 26 in the award and administration of DOT-assisted contracts. Failure by the Contractor to carry out these requirements is a material breach of this Contract, which may result in the termination of this Contract or such other remedy as the AGENCY deems appropriate.

DBE Participation

For the purpose of this Contract, the AGENCY will accept only DBE's who are:

1. Certified, at the time of bid opening or proposal evaluation, by the [certifying agency or the Unified Certification Program (UCP)]; or
2. An out-of-state firm who has been certified by either a local government, state government or Federal government entity authorized to certify DBE status or an agency whose DBE certification process has received FTA approval; or
3. Certified by another agency approved by the AGENCY.

DBE Participation Goal

The DBE participation goal for this Contract is set at 0.16%. This goal represents those elements of work under this Contract performed by qualified Disadvantaged Business Enterprises for amounts totaling not less than 0.16% of the total Contract price. Failure to meet the stated goal at the time of proposal submission may render the Bidder/Offeror non-responsive.

Proposed Submission

Each Bidder/Offeror, as part of its submission, shall supply the following information:

1. A completed DBE Utilization Form (see below) that indicates the percentage and dollar value of the total bid/contract amount to be supplied by Disadvantaged Business Enterprises under this Contract.
2. A list of those qualified DBE's with whom the Bidder/Offeror intends to contract for the performance of portions of the work under the Contract, the agreed price to be paid to each DBE for work, the Contract items or parts to be performed by each DBE, a proposed timetable for the performance or delivery of the Contract item, and other information as required by the DBE Participation Schedule (see below). No work shall be included in the Schedule that the Bidder/Offeror has reason to believe the listed DBE will

subcontract, at any tier, to other than another DBE. If awarded the Contract, the Bidder/Offeror may not deviate from the DBE Participation Schedule submitted in response to the bid. Any subsequent changes and/or substitutions of DBE firms will require review and written approval by the AGENCY.

3. An original DBE Letter of Intent (see below) from each DBE listed in the DBE Participation Schedule.
4. An original DBE Affidavit (see below) from each DBE stating that there has not been any change in its status since the date of its last certification.
5. A signed DBE commitment Letter within 72 hours.

Good Faith Efforts

If the Bidder/Offeror is unable to meet the goal set forth above (DBE Participation Goal), the AGENCY will consider the Bidder/Offeror's documented good faith efforts to meet the goal in determining responsiveness. The types of actions that the AGENCY will consider as part of the Bidder/Offeror's good faith efforts include, but are not limited to, the following:

1. Documented communication with the AGENCY's DBE Coordinator (questions of IFB or RFP requirements, subcontracting opportunities, appropriate certification, will be addressed in a timely fashion);
2. Pre-bid meeting attendance. At the pre-bid meeting, the AGENCY generally informs potential Bidder/Offeror's of DBE subcontracting opportunities;
3. The Bidder/Offeror's own solicitations to obtain DBE involvement in general circulation media, trade association publication, minority-focus media and other reasonable and available means within sufficient time to allow DBEs to respond to the solicitation;
4. Written notification to DBE's encouraging participation in the proposed Contract; and
5. Efforts made to identify specific portions of the work that might be performed by DBE's.

The Bidder/Offeror shall provide the following details, at a minimum, of the specific efforts it made to negotiate in good faith with DBE's for elements of the Contract:

1. The names, addresses, and telephone numbers of DBE's that were contacted;
2. A description of the information provided to targeted DBE's regarding the specifications and bid proposals for portions of the work;
3. Efforts made to assist DBE's contacted in obtaining bonding or insurance required by the Bidder or the Authority.

Further, the documentation of good faith efforts must include copies of each DBE and non-DBE subcontractor quote submitted when a non-DBE subcontractor was selected over a DBE for work on the contract. 49 C.F.R. § 26.53(b) (2) (VI). In determining whether a Bidder has made good faith efforts, the Authority may take into account the performance of other Bidders in meeting the Contract goals. For example, if the apparent successful Bidder failed to meet the goal, but meets or exceeds the average DBE participation obtained by other Bidders, the Authority may view this as evidence of the Bidder having made good faith efforts.

Administrative Reconsideration

Within five (5) business days of being informed by the AGENCY that it is not responsive or responsible because it has not documented sufficient good faith efforts, the Bidder/Offeror may request administrative reconsideration. The Bidder should make this request in writing to the AGENCY's [Contact Name]. The [Contact Name] will forward the Bidder/Offeror's request to a reconsideration official who will not have played any role in the original determination that the Bidder/Offeror did not document sufficient good faith efforts.

As part of this reconsideration, the Bidder/Offeror will have the opportunity to provide written documentation or argument concerning the issue of whether it met the goal or made adequate good faith efforts to do so. The Bidder/Offeror will have the opportunity to meet in person with the assigned reconsideration official to discuss the issue of whether it met the goal or made adequate good faith efforts to do so. The AGENCY will send the Bidder/Offeror a written decision on its reconsideration, explaining the basis for finding that the Bidder/Offeror did or did not meet the goal or make adequate good faith efforts to do so. The result of the reconsideration process is not administratively appealable to the Department of Transportation.

Termination of DBE Subcontractor

The Contractor shall not terminate the DBE subcontractor(s) listed in the DBE Participation Schedule (see below) without the AGENCY's prior written consent. The AGENCY may provide such written consent only if the Contractor has good cause to terminate the DBE firm. Before transmitting a request to terminate, the Contractor shall give notice in writing to the DBE subcontractor of its intent to terminate and the reason for the request. The Contractor shall give the DBE five days to respond to the notice and advise of the reasons why it objects to the proposed termination. When a DBE subcontractor is terminated or fails to complete its work on the Contract for any reason, the Contractor shall make good faith efforts to find another DBE subcontractor to substitute for the original DBE and immediately notify the AGENCY in writing of its efforts to replace the original DBE. These good faith efforts shall be directed at finding another DBE to perform at least the same amount of work under the Contract as the DBE that was terminated, to the extent needed to meet the Contract goal established for this procurement. Failure to comply with these requirements will be in accordance with Section 8 below (Sanctions for Violations).

Continued Compliance

The AGENCY shall monitor the Contractor's DBE compliance during the life of the Contract. In the event this procurement exceeds ninety (90) days, it will be the responsibility of the Contractor to submit quarterly written reports to the AGENCY that summarize the total DBE value for this Contract. These reports shall provide the following details:

- DBE utilization established for the Contract;
- Total value of expenditures with DBE firms for the quarter;
- The value of expenditures with each DBE firm for the quarter by race and gender;
- Total value of expenditures with DBE firms from inception of the Contract; and

- The value of expenditures with each DBE firm from the inception of the Contract by race and gender.

Reports and other correspondence must be submitted to the DBE Coordinator with copies provided to the [Agency Name1] and [Agency Name2]. Reports shall continue to be submitted quarterly until final payment is issued or until DBE participation is completed.

The successful Bidder/Offeror shall permit:

- The AGENCY to have access to necessary records to examine information as the AGENCY deems appropriate for the purpose of investigating and determining compliance with this provision, including, but not limited to, records of expenditures, invoices, and contract between the successful Bidder/Offeror and other DBE parties entered into during the life of the Contract.
- The authorized representative(s) of the AGENCY, the U.S. Department of Transportation, the Comptroller General of the United States, to inspect and audit all data and record of the Contractor relating to its performance under the Disadvantaged Business Enterprise Participation provision of this Contract.
- All data/record(s) pertaining to DBE shall be maintained as stated in Section [insert reference to record keeping requirements for the Project.]

Sanctions for Violations

If at any time the AGENCY has reason to believe that the Contractor is in violation of its obligations under this Agreement or has otherwise failed to comply with terms of this Section, the AGENCY may, in addition to pursuing any other available legal remedy, commence proceedings, which may include but are not limited to, the following:

- Suspension of any payment or part due the Contractor until such time as the issues concerning the Contractor’s compliance are resolved; and
- Termination or cancellation of the Contract, in whole or in part, unless the successful Contractor is able to demonstrate within a reasonable time that it is in compliance with the DBE terms stated herein.

DBE UTILIZATION FORM

The undersigned Bidder/Offeror has satisfied the requirements of the solicitation in the following manner (please check the appropriate space):

_____ The Bidder/Offer is committed to a minimum of _____% DBE utilization on this contract.

_____ The Bidder/Offeror (if unable to meet the DBE goal of 0.16%) is committed to a minimum of _____% DBE utilization on this contract and submits documentation demonstrating good faith efforts.

DBE PARTICIPATION SCHEDULE

The Bidder/Offeror shall complete the following information for all DBE's participating in the contract that comprises the DBE Utilization percent stated in the DBE Utilization Form. The Bidder/Offeror shall also furnish the name and telephone number of the appropriate contact person should the Authority have any questions in relation to the information furnished herein.

DBE IDENTIFICATION AND INFORMATION FORM

Name and Address	Contact Name and Telephone Number	Participation Percent (Of Total Contract Value)	Description Of Work To Be Performed	Race and Gender of Firm

DBE Goals Required by UDOT

Race Conscious Goal

At the time of bid, DBE participation is considered race-conscious on projects that are assigned a Goal for Bid Evaluation. The DBE commitment becomes a contract specification upon award. The Bidder must submit with its Bid Proposal a DBE Commitment that indicates:

- Name of DBE firm
- Work items to be performed
- Total dollar amount of commitment

If the DBE commitment does not meet or exceed the assigned goal, the Bidder must submit with the Bid Proposal documentation of good faith efforts.

Race Conscious is the committed dollar amount at the time of bid focused specifically on assisting only DBEs. UDOT Civil Rights must establish contract goals to meet the race conscious portion of its overall DBE goal. To ensure that the DBE program continues to be narrowly tailored to overcome the effects of discrimination, UDOT Civil Rights may adjust the use of contract goals as follows:

- If during the course of any year it is determined the overall goal will be exceeded, UDOT Civil Rights will reduce or eliminate the use of contract goals to the extent necessary to ensure the use of contract goals does not result in exceeding the overall goal.
- If it is determined that UDOT Civil Rights will fall short of its overall goal, then appropriate modifications in the use of race neutral and/or race conscious measures will be made to allow UDOT Civil Rights to meet the overall goal.

Race Neutral Goal

At the time of bid, DBE participation is considered race-neutral on projects that are NOT assigned a Goal (0%) for Bid Evaluation. In this instance, the DBE participation does not become a contract specification upon award. The Bidder must take equal opportunity action to allow DBEs to compete for and perform on subcontracts. Only work classifications that the Bidder will subcontract need to be considered in evaluating equal opportunity action in the bid preparation.

Race Neutral is the dollar amount that exceeds the committed amount at the time of bid and is, or can be, used to assist all small businesses. UDOT Civil Rights must meet the maximum feasible portion of its overall DBE goal by using race-neutral means of facilitating DBE participation. Race neutral DBE participation includes:

- Awarding a subcontract on a prime contract that does not carry a DBE goal,
- Awarding a subcontract on a prime contract in which the DBE was not considered in making the award even if there is a DBE goal.
- For the purposes of this part, race neutral includes gender neutrality.

Goal for Contract Performance

The Bidder's DBE Commitment becomes an attachment to the Bid Proposal and is a condition of award, and thereby becomes a contract specification.

The committed dollar amount meeting the project goal for bid evaluation will be considered race conscious participation. Any dollar amounts in excess of the project goal for bid evaluation will be considered race neutral participation.

Goal for Final Compliance

Percentages for final compliance will be based on actual payments to DBEs. Overruns and under-runs on individual contract items may require adjustments to the predetermined DBE

percentage for a project if those items were not related to DBE performance. "The predetermined percentage for a project" refers to the percentage of the Contractor's DBE Commitment that becomes a contract specification upon award.

The Continued Compliance states that the AGENCY will "monitor the Contractor's DBE compliance during the life of the Contract. In the event this procurement exceeds ninety (90) days, it will be the responsibility of the Contractor to submit quarterly written reports to the AGENCY that summarize the total DBE value for this Contract." This is specifically for procurement projects. The requirement for construction projects would be:

- The Subrecipient will monitor the Contractor's DBE compliance during the life of the Contract. It is the responsibility of the Contractor to submit regular reports to the Subrecipient that summarize the total DBE value for this Contract. The frequency and content of these reports will be designated by the Subrecipient.

Determination of DBE Contractor's Eligibility by UUCP

Any Contractor may apply to the UUCP for status as a DBE. Applications will be made on forms provided by the UUCP entitled "UNIFORM CERTIFICATION APPLICATION" or "Information for Determining DBE Joint Venture Eligibility," Form No. R-817. Application need not be made in connection with a particular bid. Only work contracted to certified DBE prime contractors or subcontractors to firms that have applied for and have been granted status as a DBE by the UUCP will be considered toward contract goals as established in Subsection A.

It will be the Contractor's responsibility to submit a DBE application so that the UUCP has time to review it. The UUCP will review applications in a timely manner, but is not committed to approve DBE status within any given period of time. The UUCP must have ample lead time to review, evaluate, and verify information provided with an application.

UDOT will maintain a UUCP Unified DBE Directory of DBE Contractors, vendors, service providers, and suppliers that is updated as changes occur for the purpose of providing a reference source to assist any bidder in meeting the requirements of this bid condition. Bidders must use the most current DBE information available on the website when submitting bids. A current UUCP DBE directory representing certified DBE Contractors is available on the Internet at (click on this link): <https://www.udot.utah.gov/connect/business/civil-rights/>

In meeting the requirements of this bid condition, bidders are in no way limited to the DBE Directory referred to above in seeking out and negotiating with the DBE Contractors and determining which items of work will be subcontracted to DBE Contractors. Bidders will exercise their own judgments in selecting any subcontractor to perform any portion of the work. DBE credit will not be allowed toward race-conscious goals for a firm or joint venture that has not been DBE certified by the UUCP.

Bidding Requirements

A DBE prime contractor's performance does not count toward fulfilling the DBE goal. A prime bidder who is a DBE contractor will meet the DBE goal by using other DBE subcontractors or by using good faith efforts.

DBE Bid Assurance

1. Race Conscious Goal
 - a. Race conscious measure or program is focused specifically on assisting only DBEs. This goal is the amount the prime must commit to DBEs at the time of bid or a good faith effort must be documented.

DBE Race Conscious Commitment

1. For a bid to be considered responsive, Bidders will submit the following information regarding DBE compliance.
2. Submit a DBE Commitment of work that will be subcontracted to certified DBE firm(s) as listed in the UUCP's Directory or DBE firms that have been approved by the UUCP prior to bid opening.
 - a. The names of DBE firms that will participate in the contract;
 - b. A specific description of the work each named DBE firm will perform (list specific bid items). Listed bid items will be considered committed in their entirety unless Bidders designate otherwise in their DBE Commitment.
 - i. If mobilization is a bid item partially committed to a DBE, indicate the dollar amount of the DBE mobilization.
 - ii. If a partial quantity is committed to a DBE, indicate the quantity committed to the DBE.
 - iii. If a partial performance of an item is committed to a DBE, explain what part of the item the DBE will perform;
 - c. The dollar amount of participation by each named DBE firm;
 - d. If the contract goal is not met, evidence of good faith efforts is required at the time of bid.
3. The DBE Commitment is to be included in the prepared bid, and said information will be kept confidential and will be reviewed to determine the apparent low bidder has either met the DBE Contract Goal or has documented acceptable Good Faith Efforts.

DBE Race Neutral Participation

1. Race Neutral DBE participation includes anytime a DBE;
 - a. wins a Prime Contract through customary bidding procedures,
 - b. is awarded a subcontract on a prime contract that does not carry a DBE goal (0% goal),
 - c. wins a subcontract from a prime contractor that did not consider its DBE status in making the award (e.g., a prime contractor that uses a strict low bid system to award subcontracts).

DBE Written Confirmation

1. Low Bidder will submit to the Civil Rights Office within three (3) work days after the bid opening written confirmation from each DBE participating in the contract as provided in

the Prime Contractor's DBE Commitment. The written confirmation will include the following information:

- a. A description of the work to be performed (list specific bid items). Listed bid items will be considered committed in their entirety unless Contractors designate otherwise in their DBE commitment.
 - i. If mobilization is a bid item that is partially committed, confirm the dollar amount of the mobilization to be performed.
 - ii. If a partial quantity is committed, confirm the quantity to be performed.
 - iii. If a partial performance of an item is committed, confirm what part of the item will be performed.
 - iv. Unit bid prices for each bid item committed to a DBE.
 - v. Total dollar amounts (mathematical extensions) for each bid item committed to a DBE
- b. The dollar amount of participation by each named DBE firm.

Counting DBE Participation Toward Goals for Performance

Subcontracts to DBEs that exceed the Goal for Bid Evaluation will be considered in part as race conscious participation and in part as race neutral participation. Any dollar amounts in excess of the Goal for Bid Evaluation will be considered as race neutral participation.

It is intended that the Contractor will utilize the subcontractors designated in the DBE Commitment in the performance of the contract. Any changes in the Contractor's DBE Commitment, such as substitution of a DBE subcontractor, substitution of contract items, or decrease in total dollar amount must be approved by the UDOT Civil Rights and must be covered by a Change Order. Unauthorized substitutions or eliminations may result in the imposition of sanctions. Failure to meet the Goal for Performance established at the time of award by the Contractor's DBE Commitment, without adequate justification, including concurrence of the subrecipient and Civil Rights Office, will result in the imposition of sanctions.

1. The subrecipient will recognize and grant DBE credit for work performed by DBE contractors ONLY in the types of work for which DBE certification has been granted by the UUCP prior to bid opening. It is necessary all Bidders refer to the UUCP DBE Directory for direction and guidance.
2. Contractors may count only the value of the work actually performed by the DBE toward the DBE goals.
 - a. Work performed by the DBE's own forces using "regular employees" and "regular equipment."
 - b. The cost of supplies and materials obtained and purchased by the DBE and equipment leased for the work of the contract.
 - c. Work that a DBE subcontracts to a lower tier DBE firm.
3. Contractors may not count toward the DBE goals:
 - a. Supplies and material purchased and equipment leased by the DBE from the prime Contractor or its affiliates or another subcontractor on the project.
 - b. Work that a DBE subcontracts to a lower tier non-DBE firm.

4. Contractors may count toward their goals only expenditures to a DBE that performs a commercially useful function in the work of the contract.
 - a. A DBE performs a “commercially useful function” when it is responsible for the execution of the work of the contract and is carrying out its responsibilities by actually performing, managing, and supervising the work involved. To perform a commercially useful function, the DBE must also be responsible, with respect to materials and supplies used on the contract, for negotiating price, determining quality and quantity, ordering the material, and installing (where applicable) and paying for the material itself.
 - b. The subrecipient will evaluate the amount of work subcontracted, industry practices, whether the amount the firm is to be paid under the contract is commensurate with the work it is actually performing and the DBE credit claimed for its performance of the work, and other relevant factors.
 - c. A DBE does not perform a commercially useful function if its role is limited to that of an extra participant in a transaction, contract, or project through which funds are passed in order to obtain the appearance of DBE participation. In determining whether a DBE is such an extra participant, the subrecipient must examine similar transactions, particularly those in which DBEs do not participate.
 - d. A DBE does not perform a commercially useful function if it does not perform or exercise responsibility for at least 30 percent of the total cost of its contract with its own workforce, or the DBE subcontracts a greater portion of the work of a contract than would be expected on the basis of normal industry practice for the type of work involved.
5. The subrecipient will use the following factors in determining whether a DBE trucking company is performing a commercially useful function:
 - a. The DBE must itself own and operate at least one fully licensed, insured, and operational truck used on the contract.
 - b. The DBE must be responsible for the management and supervision of the entire trucking arrangement for the purpose of meeting DBE goals.
 - c. The DBE receives credit for the total value of the transportation services it provides on the contract using trucks it owns, insures, and operates using drivers it employs.
 - d. The DBE may lease trucks from another DBE firm, including an owner operator who is certified as a DBE. The DBE who leases trucks from another DBE receives credit for the total value of the transportation services the lessee DBE provides on the contract.
 - e. The DBE may also lease trucks from a non-DBE firm, including from an owner operator. The DBE who leases trucks from a non-DBE is entitled to credit for the total value of the transportation services provided by non-DBE lessees as long as the DBE provides the employees for the leased trucks.
 - f. A lease must indicate the DBE has exclusive use of and control over the truck. This does not preclude the leased truck from working for others during the term of the lease with the consent of the DBE, so long as the lease gives the DBE absolute priority for use of the leased truck. Leased trucks must display the name and identification number of the DBE.

6. Contractors may count expenditures with DBEs for materials or supplies as provided in the following:
 - a. If the materials or supplies are obtained from a DBE manufacturer, 100 percent of the cost of the materials or supplies counts toward DBE goals.
 - b. For purposes of this paragraph, a manufacturer is a firm that operates or maintains a factory or establishment that produces, on the premises, the materials, supplies, articles, or equipment required under the contract and of the general character described by the specifications.
 - c. If the materials or supplies are purchased from a DBE regular dealer, 60 percent of the cost of the materials or supplies counts toward DBE goals.
 - d. For purposes of this paragraph, a regular dealer is a firm that owns, operates, or maintains a store, warehouse, or other establishment in which the materials, supplies, articles or equipment of the general character described by the specifications and required under the contract are bought, kept in stock, and regularly sold or leased to the public in the usual course of business.
 - i. To be a regular dealer, the firm must be an established, regular business that engages, as its principal business and under its own name, in the purchase and sale or lease of the products in question.
 - ii. A firm may be a regular dealer in such bulk items as petroleum products, steel, cement, gravel, stone, or asphalt without owning, operating or maintaining a place of business if the firm both owns and operates distribution equipment for the products. Any supplementing of regular dealers' own distribution equipment will be by a long-term lease agreement and not on an ad hoc or contract-by-contract basis.
 - iii. Packagers, brokers, manufacturers' representatives, or other persons or firms who arrange, or expedite transactions are not regular dealers.
 - iv. A DBE trucking company that picks up a product from a manufacturer or regular dealer and delivers the product to the Contractor performs a delivery service. Credit will not be given based on a percentage of the cost of the product; credit will be allowed only for the cost of the transportation service.
7. If the materials or supplies are purchased from a service provider, the fees or commission charged for assistance in the procurement of the materials and supplies, or fees or transportation charges for the delivery of materials or supplies, count toward the DBE goals.
 - a. A Service Provider is a business that is neither a manufacturer nor a regular dealer but simply transfers title of a product from manufacturer to ultimate purchaser or a firm that puts a product into a container for delivery. A service provider charges a fee or a commission for assistance in the procurement of the materials and supplies, or fees or transportation for the delivery of materials or supplies required on a job site.
 - i. Only the fees, commissions, or transportation performed by the DBE service provider count toward the DBE goals. The subrecipient must determine the fees are reasonable and not excessive as compared with fees customarily allowed for similar services.

- ii. No portion of the cost of the materials and supplies count toward the DBE goals. Documentary evidence of the supply agreements, i.e., sales contract, purchase order, etc., will be submitted to the subrecipient prior to work beginning. The agreement will set forth the estimated quantities, unit prices, total dollar amounts, material guarantees, delivery, and payment requirements including the requirements listed part E, 4, e, of this DBE Special Provision.
8. When a DBE subcontractor is terminated, or fails to complete its work on the contract for any reason, the Contractor must make good faith efforts to find another DBE subcontractor to substitute for the original DBE. Direct these good faith efforts at finding another DBE to perform at least the same amount of work under the contract as the DBE that was terminated, to the extent needed to meet the contract goal established for the project. Document the good faith efforts. If the subrecipient requests documentation under this provision, submit the documentation within 7 days, which may be extended for an additional 7 days if necessary at the request of the contractor, and the subrecipient will provide a written determination to the contractor stating whether or not good faith efforts have been demonstrated.
- a. Failure by the contractor to carry out the requirements of this part is a material breach of the contract and may result in the termination of the contract or such other remedies set forth in that section you deem appropriate if the prime contractor fails to comply with the requirements of this section.

Americans with Disabilities Act of 1990

To provide additional information about ADA to that of the Civil Rights Laws and Regulations clause in the FTA Best Practices Manual, Appendix A, see the link below to the FTA C 4710.1 Circular.

https://www.transit.dot.gov/sites/fta.dot.gov/files/docs/Final_FTA_ADA_Circular_C_4710.1.pdf

CIVIL RIGHTS EMPLOYEE PROTECTIONS

>\$2,000

49 U.S.C. § 5333(a)

40 U.S.C. §§ 3141 – 3148

29 C.F.R. part 5

18 U.S.C. § 874

29 C.F.R. part 3

40 U.S.C. §§3701-3708

29 C.F.R. part 1926

Applicability to Contracts

Certain employee protections apply to all FTA funded contracts with particular emphasis on construction related projects. The recipient will ensure that each third party contractor complies with all federal laws, regulations, and requirements, including:

1. Prevailing Wage Requirements

- a. Federal transit laws, specifically 49 U.S.C. § 5333(a), (FTA's "Davis-Bacon Related Act"); (> \$2,000)
- b. The Davis-Bacon Act, 40 U.S.C. §§ 3141 – 3144, 3146, and 3147; and
- c. U.S. DOL regulations, "Labor Standards Provisions Applicable to Contracts Covering Federally Financed and Assisted Construction (also Labor Standards Provisions Applicable to Non-construction Contracts Subject to the Contract Work Hours and Safety Standards Act)," 29 C.F.R. part 5.

2. "Anti-Kickback" Prohibitions (> \$2,000)

- a. Section 1 of the Copeland "Anti-Kickback" Act, as amended, 18 U.S.C. § 874;
- b. Section 2 of the Copeland "Anti-Kickback" Act, as amended, 40 U.S.C. § 3145; and
- c. U.S. DOL regulations, "Contractors and Subcontractors on Public Building or Public Work Financed in Whole or in part by Loans or Grants from the United States," 29 C.F.R. part 3.

3. Contract Work Hours and Safety Standards

- a. Contract Work Hours and Safety Standards Act, as amended, 40 U.S.C. §§ 3701-3708; (> \$100,000) and supplemented by Department of Labor (DOL) regulations, 29 C.F.R. part 5; and
- b. U.S. DOL regulations, "Safety and Health Regulations for Construction," 29 C.F.R. part 1926.

Flow Down

These requirements extend to all third party contractors and their contracts at every tier and subrecipients and their subcontracts at every tier. The Davis-Bacon Act and the Copeland "Anti-Kickback" Act apply to all prime construction, alteration or repair contracts in excess of \$2,000. The Contract Work Hours and Safety Standards Act apply to all FTA funded contracts in excess of \$100,000 that involve the employment of mechanics or laborers.

Clause Language

The recipient must place a copy of the current prevailing wage determination issued by the Department of Labor in each solicitation. The decision to award a contract or subcontract must be conditioned upon the acceptance of the wage determination. In addition, recipients can draw on the following language for inclusion in their federally funded procurements.

Prevailing Wage and Anti-Kickback

For all prime construction, alteration or repair contracts in excess of \$2,000 awarded by FTA, the Contractor shall comply with the Davis-Bacon Act and the Copeland "Anti-Kickback" Act.

Under 49U.S.C. § 5333(a), prevailing wage protections apply to laborers and mechanics employed on FTA assisted construction, alteration, or repair projects. The Contractor will comply with the Davis-Bacon Act, 40 U.S.C. §§ 3141-3144, and 3146-3148 as supplemented by DOL regulations at 29 C.F.R. part 5, "Labor Standards Provisions Applicable to Contracts Governing Federally Financed and Assisted Construction." In accordance with the statute, the Contractor shall pay wages to laborers and mechanics at a rate not less than the prevailing wages specified in a wage determination made by the Secretary of Labor. In addition, the Contractor agrees to pay wages not less than once a week. The Contractor shall also comply with the Copeland "Anti-Kickback" Act (40 U.S.C. § 3145), as supplemented by DOL regulations at 29 C.F.R. part 3, "Contractors and Subcontractors on Public Building or Public Work Financed in Whole or in part by Loans or Grants from the United States." The Contractor is prohibited from inducing, by any means, any person employed in the construction, completion, or repair of public work, to give up any part of the compensation to which he or she is otherwise entitled.

Contract Work Hours and Safety Standards

For all contracts in excess of \$100,000 that involve the employment of mechanics or laborers, the Contractor shall comply with the Contract Work Hours and Safety Standards Act (40 U.S.C. §§ 3701- 3708), as supplemented by the DOL regulations at 29 C.F.R. part 5. Under 40 U.S.C. § 3702 of the Act, the Contractor shall compute the wages of every mechanic and laborer, including watchmen and guards, on the basis of a standard work week of 40 hours. Work in excess of the standard work week is permissible provided that the worker is compensated at a rate of not less than one and a half times the basic rate of pay for all hours worked in excess of 40 hours in the work week. The requirements of 40U.S.C. § 3704 are applicable to construction work and provide that no laborer or mechanic be required to work in surroundings or under working conditions which are unsanitary, hazardous or dangerous. These requirements do not apply to the purchase of supplies or materials or articles ordinarily available on the open market, or to contracts for transportation or transmission of intelligence.

In the event of any violation of the clause set forth herein, the Contractor and any subcontractor responsible therefore shall be liable for the unpaid wages. In addition, the Contractor and subcontractor shall be liable to the United States (in the case of work done under contract for the District of Columbia or a territory, to such District or to such territory), for liquidated damages. Such liquidated damages shall be computed with respect to each individual laborer or mechanic, including watchmen and guards, employed in violation of this clause in the sum of \$10 for each calendar day on which such individual was required or permitted to work in excess of the standard workweek of forty hours without payment of the overtime wages required by this clause.

The FTA shall upon its own action or upon written request of an authorized representative of the Department of Labor withhold or cause to be withheld, from any moneys payable on account of work performed by the Contractor or subcontractor under any such contract or any other Federal contract with the same prime Contractor, or any other federally-assisted contract subject

to the Contract Work Hours and Safety Standards Act, which is held by the same prime Contractor, such sums as may be determined to be necessary to satisfy any liabilities of such Contractor or subcontractor for unpaid wages and liquidated damages as provided in this section.

The Contractor or subcontractor shall insert in any subcontracts the clauses set forth in this section and also a clause requiring the subcontractors to include these clauses in any lower tier subcontracts. The prime Contractor shall be responsible for compliance by any subcontractor or lower tier subcontractor with the clauses set forth in this agreement.

Contract Work Hours and Safety Standards for Awards Not Involving Construction

The Contractor shall comply with all federal laws, regulations, and requirements providing wage and hour protections for non-construction employees, in accordance with 40 U.S.C. § 3702, Contract Work Hours and Safety Standards Act, and other relevant parts of that Act, 40 U.S.C. § 3701 et seq., and U.S. DOL regulations, "Labor Standards Provisions Applicable to Contracts Covering Federally Financed and Assisted Construction (also Labor Standards Provisions Applicable to Non-construction Contracts Subject to the Contract Work Hours and Safety Standards Act)," 29 C.F.R. part 5.

The Contractor shall maintain payrolls and basic payroll records during the course of the work and shall preserve them for a period of three (3) years from the completion of the contract for all laborers and mechanics, including guards and watchmen, working on the contract. Such records shall contain the name and address of each such employee, social security number, correct classifications, hourly rates of wages paid, daily and weekly number of hours worked, deductions made, and actual wages paid.

Such records maintained under this paragraph shall be made available by the Contractor for inspection, copying, or transcription by authorized representatives of the FTA and the Department of Labor, and the Contractor will permit such representatives to interview employees during working hours on the job.

The contractor shall require the inclusion of the language of this clause within subcontracts of all tiers.

CIVIL RIGHTS PROMPT PAYMENT

All non TVM purchases

49 CFR Part 26.29

Prompt payment for the work accomplished is an integral part of the concept of a commercially useful function but is a requirement on all FTA projects for DBE and non-DBE companies.

- Prompt payment means that the prime contractor is to pay each subcontractor, and each subcontractor is to pay any lower tier subcontractor, within 30 days of being paid by the Subrecipient.
- Prompt payment entries are to be entered for each subcontractor in the method approved so that it can be monitored and verified for compliance.

CLEAN AIR ACT AND FEDERAL WATER POLLUTION CONTROL ACT

>\$150,000

42 U.S.C. §§ 7401 – 7671q

33 U.S.C. §§ 1251-1387

2 C.F.R. part 200, Appendix II (G)

Applicability to Contracts

The Clean Air and Clean Water Act requirements apply to each contract and subcontract exceeding \$150,000. Each contract and subcontract must contain a provision that requires the recipient to agree to comply with all applicable standards, orders or regulations issued pursuant to the Clean Air Act (42 U.S.C. 7401–7671q) and the Federal Water Pollution Control Act as amended (33 U.S.C. 1251– 1387). Violations must be reported to the Federal awarding agency and the Regional Office of the Environmental Protection Agency (EPA).

Flow Down

The Clean Air Act and Federal Water Pollution Control Act requirements extend to all third party contractors and their contracts at every tier and subrecipients and their subcontracts at every tier.

Clause Language

Recipients can draw on the following language for inclusion in their federally funded procurements.

The Contractor agrees:

- 1) It will not use any violating facilities;
- 2) It will report the use of facilities placed on or likely to be placed on the U.S. EPA "List of Violating Facilities;"
- 3) It will report violations of use of prohibited facilities to FTA; and
- 4) It will comply with the inspection and other requirements of the Clean Air Act, as amended, (42 U.S.C. §§ 7401 – 7671q); and the Federal Water Pollution Control Act as amended, (33 U.S.C. §§ 1251-1387).

DISPUTES, BREACHES, DEFAULTS, AND LITIGATION

(a) FTA Interest. FTA has a vested interest in the settlement of any violation of federal law, regulation, or requirement, or any disagreement involving the Award, the accompanying Underlying Agreement, and any Amendments thereto including, but not limited to, a default, breach, major dispute, or litigation, and FTA reserves the right to concur in any settlement or compromise.

(b) Notification to FTA; Flow Down Requirement. If a current or prospective legal matter that may affect the Federal Government emerges, the Recipient must promptly notify the FTA Chief Counsel and FTA Regional Counsel for the Region in which the Recipient is located. The Recipient must include a similar notification requirement in its Third Party Agreements and must require each Third Party Participant to include an equivalent provision in its sub agreements at every tier, for any agreement that is a "covered transaction" according to 2 C.F.R. §§ 180.220 and 1200.220.

(1) The types of legal matters that require notification include, but are not limited to, a major dispute, breach, default, litigation, or naming the Federal 95 Government as a party to litigation or a legal disagreement in any forum for any reason.

(2) Matters that may affect the Federal Government include, but are not limited to, the Federal Government's interests in the Award, the accompanying Underlying Agreement, and any Amendments thereto, or the Federal Government's administration or enforcement of federal laws, regulations, and requirements.

(3) Additional Notice to U.S. DOT Inspector General. The Recipient must promptly notify the U.S. DOT Inspector General in addition to the FTA Chief Counsel or Regional Counsel for the Region in which the Recipient is located, if the Recipient has knowledge of potential fraud, waste, or abuse occurring on a Project receiving assistance from FTA. The notification provision applies if a person has or may have submitted a false claim under the False Claims Act, 31 U.S.C. § 3729, et seq., or has or may have committed a criminal or civil violation of law pertaining to such matters as fraud, conflict of interest, bid rigging, misappropriation or embezzlement, bribery, gratuity, or similar misconduct involving federal assistance. This responsibility occurs whether the Project is subject to this Agreement or another agreement between the Recipient and FTA, or an agreement involving a principal, officer, employee, agent, or Third Party Participant of the Recipient. It also applies to subcontractors at any tier. Knowledge, as used in this paragraph, includes, but is not limited to, knowledge of a criminal or civil investigation by a Federal, state, or local law enforcement or other investigative agency, a criminal indictment or civil complaint, or probable cause that could support a criminal indictment, or any other credible information in the possession of the Recipient. In this paragraph, "promptly" means to refer information without delay and without change. This notification provision applies to all divisions of the Recipient, including divisions tasked with law enforcement or investigatory functions.

(c) Federal Interest in Recovery. The Federal Government retains the right to a proportionate share of any proceeds recovered from any third party, based on the percentage of the federal share for the Underlying Agreement. Notwithstanding the preceding sentence, the Recipient may return all liquidated damages it receives to its Award Budget for its Underlying Agreement rather than return the federal share of those liquidated damages to the Federal Government, provided that the Recipient receives FTA's prior written concurrence.

(d) Enforcement. The Recipient must pursue its legal rights and remedies available under any third party agreement or any federal, state, or local law or regulation.

ENERGY CONSERVATION

42 U.S.C. 6321 et seq.
49 C.F.R. part 622, subpart C

Applicability to Contracts

The Energy Policy and Conservation requirements are applicable to all contracts. The Recipient agrees to, and assures that its subrecipients, if any, will comply with the mandatory energy standards and policies of its state energy conservation plans under the Energy Policy and Conservation Act, as amended, 42 U.S.C. § 6201 et seq., and perform an energy assessment for any building constructed, reconstructed, or modified with federal assistance as required under FTA regulations, "Requirements for Energy Assessments," 49 C.F.R. part 622, subpart C.

Flow Down

These requirements extend to all third party contractors and their contracts at every tier and

subrecipients and their subcontracts at every tier.

Clause Language

No specific clause is recommended in the regulations because the Energy Conservation requirements are so dependent on the state energy conservation plan. Recipients can draw on the following language for inclusion in their federally funded procurements.

Energy Conservation

The contractor agrees to comply with mandatory standards and policies relating to energy efficiency, which are contained in the state energy conservation plan issued in compliance with the Energy Policy and Conservation Act.

FEDERAL CHANGES

2 CFR Part 1201

Applicability to Contracts

The Federal Changes requirement applies to all contracts.

Applicability to Micro-Purchases Micro-purchases are defined as those purchases under \$10,000. These requirements do not apply to micro-purchases; except for construction contracts over \$2,000.

Flow Down Requirement: The Federal Changes requirement flows down appropriately to each applicable changed requirement.

Clause Language: The following language has been developed by FTA.

Federal Changes - Contractor shall at all times comply with all applicable FTA regulations, policies, procedures and directives, including without limitation those listed directly or by reference in the Master Agreement between Purchaser and FTA, as they may be amended or promulgated from time to time during the term of this contract. Contractor's failure to so comply shall constitute a material breach of this contract.

FLY AMERICA

Foreign transportation or travel of people or goods by air

49 U.S.C. § 40118

41 C.F.R. part 301-10

48 C.F.R. part 47.4

Applicability to Contracts

The Fly America requirements apply to the transportation of persons or property, by air, between a place in the U.S. and a place outside the U.S., or between places outside the U.S., when the FTA will participate in the costs of such air transportation. Transportation on a foreign air carrier is permissible when provided by a foreign air carrier under a code share agreement when the ticket identifies the U.S. air carrier's designator code and flight number. Transportation by a foreign air carrier is also permissible if there is a bilateral or multilateral air transportation

agreement to which the U.S. Government and a foreign government are parties and which the U.S. DOT has determined meets the requirements of the Fly America Act.

Flow Down Requirements

The Fly America requirements flow down from FTA recipients and subrecipients to first tier contractors who are responsible for ensuring that lower tier contractors and subcontractors are in compliance.

Clause Language

A sample clause is provided for Federal contracts at 48 C.F.R. 52.247-63. Recipients can draw on the following language for inclusion in their federally funded procurements.

FTA proposes the following language, modified from the Federal clause.

Fly America Requirements

- 1) Definitions. As used in this clause--
“International air transportation” means transportation by air between a place in the United States and a place outside the United States or between two places both of which are outside the United States.

“United States” means the 50 States, the District of Columbia, and outlying areas.

“U.S.-flag air carrier” means an air carrier holding a certificate under 49 U.S.C. Chapter 411.
- 2) b) When Federal funds are used to fund travel, Section 5 of the International Air Transportation Fair Competitive Practices Act of 1974 (49 U.S.C. 40118) (Fly America Act) requires contractors, recipients, and others use U.S.-flag air carriers for U.S. Government-financed international air transportation of personnel (and their personal effects) or property, to the extent that service by those carriers is available. It requires the Comptroller General of the United States, in the absence of satisfactory proof of the necessity for foreign-flag air transportation, to disallow expenditures from funds, appropriated or otherwise established for the account of the United States, for international air transportation secured aboard a foreign-flag air carrier if a U.S.-flag air carrier is available to provide such services.
- 3) If available, the Contractor, in performing work under this contract, shall use U.S.-flag carriers for international air transportation of personnel (and their personal effects) or property.
- 4) In the event that the Contractor selects a carrier other than a U.S.-flag air carrier for international air transportation, the Contractor shall include a statement on vouchers involving such transportation essentially as follows:

Statement of Unavailability of U.S.-Flag Air Carriers

International air transportation of persons (and their personal effects) or property by U.S.-flag air carrier was not available or it was necessary to use foreign-flag air carrier service for the following reasons. See FAR § 47.403. [State reasons]:

(End of statement)

5) The Contractor shall include the substance of this clause, including this paragraph (e), in each subcontract or purchase under this contract that may involve international air transportation.

(End of Clause)

GOVERNMENT-WIDE DEBARMENT AND SUSPENSION

>\$25,000

2 C.F.R. part 180

2 C.F.R part 1200

2 C.F.R. § 200.213

2 C.F.R. part 200 Appendix II (I)

Executive Order 12549

Executive Order 12689

Background and Applicability

A contract award (of any tier) in an amount expected to equal or exceed \$25,000 or a contract award at any tier for a federally required audit (irrespective of the contract amount) must not be made to parties listed on the government-wide exclusions in the System for Award Management (SAM), in accordance with the OMB guidelines at 2 C.F.R. part 180. The Excluded Parties List

System in SAM contains the names of parties debarred, suspended, or otherwise excluded by agencies, as well as parties declared ineligible under statutory or regulatory authority other than Executive Order 12549.

Recipients, contractors, and subcontractors (at any level) that enter into covered transactions are required to verify that the entity (as well as its principals and affiliates) with which they propose to contract or subcontract is not excluded or disqualified. This is done by: (a) checking the SAM exclusions; (b) collecting a certification from that person; or (c) adding a clause or condition to the contract or subcontract.

Flow Down

Recipients, contractors, and subcontractors who enter into covered transactions with a participant at the next lower level, must require that participant to: (a) comply with subpart C of 2 C.F.R. part 180, as supplemented by 2 C.F.R. part 1200; and (b) pass the requirement to comply with subpart C of 2 C.F.R. part 180 to each person with whom the participant enters into a covered transaction at the next lower tier.

Clause Language

Recipients can draw on the following language for inclusion in their federally funded procurements.

Debarment, Suspension, Ineligibility and Voluntary Exclusion

The Contractor shall comply and facilitate compliance with U.S. DOT regulations, "Nonprocurement Suspension and Debarment," 2 C.F.R. part 1200, which adopts and supplements the U.S. Office of Management and Budget (U.S. OMB) "Guidelines to Agencies on Governmentwide Debarment and Suspension (Nonprocurement)," 2 C.F.R. part 180. These provisions apply to each contract at any tier of \$25,000 or more, and to each contract at any tier for a federally required audit (irrespective of the contract amount), and to each contract at any tier that must be approved by an FTA official irrespective of the contract amount. As such, the Contractor shall verify that its principals, affiliates, and subcontractors are eligible to participate in this federally funded contract and are not presently declared by any Federal department or agency to be:

- a) Debarred from participation in any federally assisted Award;
- b) Suspended from participation in any federally assisted Award;
- c) Proposed for debarment from participation in any federally assisted Award;
- d) Declared ineligible to participate in any federally assisted Award;
- e) Voluntarily excluded from participation in any federally assisted Award; or
- f) Disqualified from participation in any federally assisted Award.

By signing and submitting its bid or proposal, the bidder or proposer certifies as follows:

The certification in this clause is a material representation of fact relied upon by the AGENCY. If

it is later determined by the AGENCY that the bidder or proposer knowingly rendered an erroneous certification, in addition to remedies available to the AGENCY, the Federal Government may pursue available remedies, including but not limited to suspension and/or debarment. The bidder or proposer agrees to comply with the requirements of 2 C.F.R. part 180, subpart C, as supplemented by 2 C.F.R. part 1200, while this offer is valid and throughout the period of any contract that may arise from this offer. The bidder or proposer further agrees to include a provision requiring such compliance in its lower tier covered transactions.

_____ Signature of Contractor's Authorized Official

_____ Name and Title of Contractor's Authorized Official

_____ Date

INCORPORATION OF FEDERAL TRANSIT ADMINISTRATION (FTA) TERMS

FTA Circular 4220.1F

Applicability to Contracts

The incorporation of FTA terms applies to all contracts.

Applicability to Micro-Purchases:

Micro-purchases are defined as those purchases under \$10,000. These requirements do not apply to micro-purchases; except for construction contracts over \$2,000.

Flow Down Requirement

The incorporation of FTA terms has unlimited flow down.

Clause Language

FTA has developed the following incorporation of terms language: Incorporation of Federal Transit Administration (FTA) Terms - The preceding provisions include, in part, certain Standard Terms and Conditions required by DOT, whether or not expressly set forth in the preceding contract provisions. All contractual provisions required by DOT, as set forth in FTA Circular 4220.1F are hereby incorporated by reference. Anything to the contrary herein notwithstanding, all FTA mandated terms shall be deemed to control in the event of a conflict with other provisions contained in this Agreement. The Contractor shall not perform any act, fail to perform any act, or refuse to comply with any (name of grantee) to be in violation of the FTA terms and conditions.

LOBBYING RESTRICTIONS

>\$100,000

31 U.S.C. § 1352

2 C.F.R. § 200.450

2 C.F.R. part 200 appendix II (J)

49 C.F.R. part 20

Applicability to Contracts

The lobbying requirements apply to all contracts and subcontracts of \$100,000 or more at any tier under a Federal grant. If any funds other than Federal appropriated funds have been paid or will be paid to any person for influencing or attempting to influence an officer or employee of any agency, a Member of Congress, an officer or employee of Congress, or an employee of a Member of Congress in connection with this agreement, the payor must complete and submit

the Standard Form-LLL, "Disclosure Form to Report Lobbying," in accordance with its instructions.

Flow Down

The lobbying requirements mandate the maximum flow down pursuant to Byrd Anti-Lobbying Amendment, 31 U.S.C. § 1352(b)(5).

Clause Language

49 C.F.R. part 20, Appendices A and B provide specific language for inclusion in FTA funded third party contracts as follows:

Lobbying Restrictions

The undersigned certifies, to the best of his or her knowledge and belief, that:

1. No Federal appropriated funds have been paid or will be paid, by or on behalf of the undersigned, to any person for influencing or attempting to influence an officer or employee of an agency, a Member of Congress, an officer or employee of Congress, or an employee of a Member of Congress in connection with the awarding of any Federal contract, the making of any Federal grant, the making of any Federal loan, the entering into any cooperative agreement, and the extension, continuation, renewal, amendment, or modification of any Federal contract, grant, loan, or cooperative agreement.
2. If any funds other than Federal appropriated funds have been paid or will be paid to any person for influencing or attempting to influence an officer or employee of any agency, a Member of Congress, an officer or employee of Congress, or an employee of a Member of Congress in connection with this Federal contract, grant, loan, or cooperative agreement, the undersigned shall complete and submit Standard Form-LLL, "Disclosure Form to Report Lobbying," in accordance with its instructions.
3. The undersigned shall require that the language of this certification be included in the award documents for all sub-awards at all tiers (including subcontracts, sub-grants, and contracts under grants, loans, and cooperative agreements) and that all subrecipients shall certify and disclose accordingly.

This certification is a material representation of fact upon which reliance was placed when this transaction was made or entered into. Submission of this certification is a prerequisite for making or entering into this transaction imposed by section 1352, title 31, U.S. Code. Any person who fails to file the required certification shall be subject to a civil penalty of not less than \$10,000 and not more than \$100,000 for each such failure.

_____ Signature of Contractor's Authorized Official

_____ Name and Title of Contractor's Authorized Official

_____ Date

NATIONAL INTELLIGENT TRANSPORTATION SYSTEMS (ITS) ARCHITECTURE AND STANDARDS

23 U.S.C. Section 517(d)

23 U.S.C. §502

Intelligent transportation system (ITS) property and services must comply with the National ITS Architecture and Standards to the extent required by 23 U.S.C. Section 517(d) and FTA Notice, "FTA National ITS Architecture Policy on Transit Projects," 66 FR 1455 et seq., January 8, 2001, and later published policies or implementing directives FTA may issue. Consequently, third party contracts involving ITS are likely to require provisions to ensure compliance with Federal requirements.

NO GOVERNMENT OBLIGATION TO THIRD PARTIES

Applicability to Contracts

The No Obligation clause applies to all third party contracts that are federally funded.

Flow Down

The No Obligation clause extends to all third party contractors and their contracts at every tier and subrecipients and their subcontracts at every tier.

Clause Language

Recipients can draw on the following language for inclusion in their federally funded procurements.

No Federal Government Obligation to Third Parties.

The Recipient and Contractor acknowledge and agree that, notwithstanding any concurrence by the Federal Government in or approval of the solicitation or award of the underlying Contract, absent the express written consent by the Federal Government, the Federal Government is not a party to this Contract and shall not be subject to any obligations or liabilities to the Recipient, Contractor or any other party (whether or not a party to that contract) pertaining to any matter resulting from the underlying Contract. The Contractor agrees to include the above clause in each subcontract financed in whole or in part with Federal assistance provided by the FTA. It is further agreed that the clause shall not be modified, except to identify the subcontractor who will be subject to its provisions.

NOTIFICATION OF FEDERAL PARTICIPATION FOR STATES

Limited to states

FTA Master Agreement §37

Federal grant monies ((insert total UDOT federal grant amount)) fund this contract, in whole or in part (Section 53XX – CFDA 20.5XX). As such, agencies receiving such funds and contractors awarded contracts that use such funds must comply with certain Federal certifications and clause requirements. This includes, for purchases of rolling stock over \$150,000, compliance with Buy America Act requirements, including pre-award and post-delivery audit requirements and certifications, as well as requirements and certifications applicable under the Federal Motor Vehicle Safety Standard (FMVSS). It is the contractor's responsibility to be aware of the pertinent certifications and contract clauses, as identified by the Issuing Agency for the instant procurement and ensure compliance with such requirements prior to award and throughout the term of any resultant contract. The full text of these clauses is available at the National Rural Transit Assistance Program (RTAP) website under "ProcurementPro." The website address is: <http://www.nationalrtap.org/>

PRIVACY ACT
Contracts with personal identifier files
5 U.S.C. 552

Applicability to Contracts

When a grantee maintains files on drug and alcohol enforcement activities for FTA, and those files are organized so that information could be retrieved by personal identifier, the Privacy Act requirements apply to all contracts.

Applicability to Micro-Purchases

Micro-purchases are defined as those purchases under \$10,000. These requirements do not apply to micro-purchases; except for construction contracts over \$2,000.

Flow Down Requirement

The Federal Privacy Act requirements flow down to each third party contractor and their contracts at every tier.

Clause Language

The text of the following clause has not been mandated by statute or specific regulation, but has been developed by FTA.

Contracts Involving Federal Privacy Act Requirements - The following requirements apply to the Contractor and its employees that administer any system of records on behalf of the Federal Government under any contract:

(1) The Contractor agrees to comply with, and assures the compliance of its employees with, the information restrictions and other applicable requirements of the Privacy Act of 1974, 5 U.S.C. § 552a. Among other things, the Contractor agrees to obtain the express consent of the Federal Government before the Contractor or its employees operate a system of records on behalf of the Federal Government. The Contractor understands that the requirements of the Privacy Act, including the civil and criminal penalties for violation of that Act, apply to those individuals involved, and that failure to comply with the terms of the Privacy Act may result in termination of the underlying contract.

(2) The Contractor also agrees to include these requirements in each subcontract to administer any system of records on behalf of the Federal Government finance in whole or in part with Federal assistance provided by FTA.

PROGRAM FRAUD AND FALSE OR FRAUDULENT STATEMENTS AND RELATED ACTS

49 U.S.C. § 5323(l) (1)
31 U.S.C. §§ 3801-3812
18 U.S.C. § 1001
49 C.F.R. part 31

Applicability to Contracts

The Program Fraud clause applies to all third party contracts that are federally funded.

Flow Down

The Program Fraud clause extends to all third party contractors and their contracts at every tier and subrecipients and their subcontracts at every tier. These requirements flow down to contractors and subcontractors who make, present, or submit covered claims and statements.

Clause Language

Recipients can draw on the following language for inclusion in their federally funded procurements.

Program Fraud and False or Fraudulent Statements or Related Acts

The Contractor acknowledges that the provisions of the Program Fraud Civil Remedies Act of 1986, as amended, 31 U.S.C. § 3801 et seq. and U.S. DOT regulations, "Program Fraud Civil Remedies," 49 C.F.R. part 31, apply to its actions pertaining to this Project. Upon execution of the underlying contract, the Contractor certifies or affirms the truthfulness and accuracy of any statement it has made, it makes, it may make, or causes to be made, pertaining to the underlying contract or the FTA assisted project for which this contract work is being performed. In addition to other penalties that may be applicable, the Contractor further acknowledges that if it makes, or causes to be made, a false, fictitious, or fraudulent claim, statement, submission, or certification, the Federal Government reserves the right to impose the penalties of the Program Fraud Civil Remedies Act of 1986 on the Contractor to the extent the Federal Government deems appropriate.

The Contractor also acknowledges that if it makes, or causes to be made, a false, fictitious, or fraudulent claim, statement, submission, or certification to the Federal Government under a contract connected with a project that is financed in whole or in part with Federal assistance originally awarded by FTA under the authority of 49 U.S.C. chapter 53, the Government reserves the right to impose the penalties of 18 U.S.C. § 1001 and 49 U.S.C. § 5323(l) on the Contractor, to the extent the Federal Government deems appropriate.

The Contractor agrees to include the above two clauses in each subcontract financed in whole or in part with Federal assistance provided by FTA. It is further agreed that the clauses shall not be modified, except to identify the subcontractor who will be subject to the provisions.

**PROHIBITION ON CERTAIN TELECOMMUNICATIONS AND VIDEO SURVEILLANCE
SERVICES OR EQUIPMENT**

CFR Title 2, Subtitle A, Chapter II, Part 200, Subpart C, § 200.216.

(a) Recipients and subrecipients are prohibited from obligating or expending loan or grant funds to:

(1) Procure or obtain;

(2) Extend or renew a contract to procure or obtain; or

(3) Enter into a contract (or extend or renew a contract) to procure or obtain equipment, services, or systems that uses covered telecommunications equipment or services as a substantial or essential component of any system, or as critical technology as part of any system. As described in [Public Law 115-232](#), section 889, covered telecommunications equipment is telecommunications equipment produced by Huawei Technologies Company or ZTE Corporation (or any subsidiary or affiliate of such entities).

(i) For the purpose of public safety, security of government facilities, physical security surveillance of critical infrastructure, and other national security purposes, video surveillance and telecommunications equipment produced by Hytera Communications Corporation, Hangzhou Hikvision Digital Technology Company, or Dahua Technology Company (or any subsidiary or affiliate of such entities).

(ii) Telecommunications or video surveillance services provided by such entities or using such equipment.

(iii) Telecommunications or video surveillance equipment or services produced or provided by an entity that the Secretary of Defense, in consultation with the Director of the National Intelligence or the Director of the Federal Bureau of Investigation, reasonably believes to be an entity owned or controlled by, or otherwise connected to, the government of a covered foreign country.

(b) In implementing the prohibition under [Public Law 115-232](#), section 889, subsection (f), paragraph (1), heads of executive agencies administering loan, grant, or subsidy programs shall prioritize available funding and technical support to assist affected businesses, institutions and organizations as is reasonably necessary for those affected entities to transition from covered communications equipment and services, to procure replacement equipment and services, and to ensure that communications service to users and customers is sustained.

(c) See [Public Law 115-232](#), section 889 for additional information.

(d) See also [§ 200.471](#).

RECYCLED PRODUCTS

Contract for items designated by EPA, when procuring \$10,000 or more per year

42 U.S.C. § 6962

40 C.F.R. part 247

2 C.F.R. part § 200.322

Applicability to Contracts

The Resource Conservation and Recovery Act, as amended, (42 U.S.C. § 6962 et seq.), requires States and local governmental authorities to provide a competitive preference to products and services that conserve natural resources, protect the environment, and are energy efficient. Recipients are required to procure only items designated in guidelines of the Environmental Protection Agency (EPA) at 40 C.F.R. part 247 that contain the highest percentage of recovered materials practicable, consistent with maintaining a satisfactory level of competition, where the purchase price of the item exceeds \$10,000 or the value of the quantity acquired during the preceding fiscal year exceeded \$10,000.

Flow Down

These requirements extend to all third party contractors and their contracts at every tier and subrecipients and their subcontracts at every tier where the value of an EPA designated item exceeds \$10,000.

Clause Language

Recipients can draw on the following language for inclusion in their federally funded procurements.

Recovered Materials

The Contractor agrees to provide a preference for those products and services that conserve natural resources, protect the environment, and are energy efficient by complying with and facilitating compliance with Section 6002 of the Resource Conservation and Recovery Act, as amended, 42 U.S.C. § 6962, and U.S. Environmental Protection Agency (U.S. EPA), "Comprehensive Procurement Guideline for Products Containing Recovered Materials," 40 C.F.R. part 247.

SAFE OPERATION OF MOTOR VEHICLES

(a) Seat Belt Use. The Recipient agrees to implement Executive Order No. 13043, "Increasing Seat Belt Use in the United States," April 16, 1997, 23 U.S.C. § 402 note, (62 Fed. Reg. 19217), by:

- (1) Adopting and promoting on-the-job seat belt use policies and programs for its employees and other personnel that operate company-owned vehicles, company-rented vehicles, or personally operated vehicles; and 91
- (2) Including a "Seat Belt Use" provision in each third party agreement related to the Award.

(b) Distracted Driving, Including Text Messaging While Driving. The Recipient agrees to comply with:

- (1) Executive Order No. 13513, "Federal Leadership on Reducing Text Messaging While Driving," October 1, 2009, 23 U.S.C. § 402 note, (74 Fed. Reg. 51225);
- (2) U.S. DOT Order 3902.10, "Text Messaging While Driving," December 30, 2009; and
- (3) The following U.S. DOT Special Provision pertaining to Distracted Driving:
 - (i) Safety. The Recipient agrees to adopt and enforce workplace safety policies to decrease crashes caused by distracted drivers, including policies to ban text messaging while using an electronic device supplied by an employer, and driving a vehicle the driver owns or rents, a vehicle Recipient owns, leases, or rents, or a privately-owned vehicle when on official business in connection with the Award, or when performing any work for or on behalf of the Award;
 - (ii) Recipient Size. The Recipient agrees to conduct workplace safety initiatives in a manner commensurate with its size, such as establishing new rules and programs to prohibit text messaging while driving, re-evaluating the existing programs to prohibit text messaging while driving, and providing education, awareness, and other outreach to employees about the safety risks associated with texting while driving; and
 - (iii) Extension of Provision. The Recipient agrees to include the preceding Special Provision of section 34(b)(3)(i) – (ii) of this Master Agreement in its third party agreements, and encourage its Third Party Participants to comply with this Special Provision, and include this Special Provision in each third party subagreement at each tier supported with federal assistance.

SEISMIC SAFETY
New Buildings & additions.
42 U.S.C. 7701 et seq.
49 C.F.R. part 41
Executive Order (E.O.) 12699

Applicability to Contracts

The Seismic Safety requirements apply only to contracts for the construction of new buildings or additions to existing buildings.

Flow Down

The Seismic Safety requirements flow down from FTA recipients and subrecipients to first tier contractors to assure compliance with the applicable building standards for Seismic Safety, including the work performed by all subcontractors.

Clauses Language

Recipients can draw on the following language for inclusion in their federally funded procurements.

Seismic Safety

The contractor agrees that any new building or addition to an existing building will be designed and constructed in accordance with the standards for Seismic Safety required in Department of Transportation (DOT) Seismic Safety Regulations 49 C.F.R. part 41 and will certify to compliance to the extent required by the regulation. The contractor also agrees to ensure that all work performed under this contract, including work performed by a subcontractor, is in compliance with the standards required by the Seismic Safety regulations and the certification of compliance issued on the project.

TERMINATION

>\$10,000

2 C.F.R. § 200.339

2 C.F.R. part 200, Appendix II (B)

Applicability to Contracts

All contracts in excess of \$10,000 must address termination for cause and for convenience, including the manner by which it will be effected and the basis for settlement.

Flow Down

For all contracts in excess of \$10,000, the Termination clause extends to all third party contractors and their contracts at every tier and subrecipients and their subcontracts at every tier.

Clause Language

Recipients can draw on the following language for inclusion in their federally funded procurements.

Termination for Convenience (General Provision)

The AGENCY may terminate this contract, in whole or in part, at any time by written notice to the Contractor when it is in the AGENCY's best interest. The Contractor shall be paid its costs, including contract close-out costs, and profit on work performed up to the time of termination. The Contractor shall promptly submit its termination claim to AGENCY to be paid the Contractor. If the Contractor has any property in its possession belonging to AGENCY, the Contractor will account for the same, and dispose of it in the manner AGENCY directs.

Termination for Default [Breach or Cause] (General Provision)

If the Contractor does not deliver supplies in accordance with the contract delivery schedule, or if the contract is for services, the Contractor fails to perform in the manner called for in the contract, or if the Contractor fails to comply with any other provisions of the contract, the AGENCY may terminate this contract for default. Termination shall be effected by serving a Notice of Termination on the Contractor setting forth the manner in which the Contractor is in default. The Contractor will be paid only the contract price for supplies delivered and accepted, or services performed in accordance with the manner of performance set forth in the contract.

If it is later determined by the AGENCY that the Contractor had an excusable reason for not performing, such as a strike, fire, or flood, events which are not the fault of or are beyond the control of the Contractor, the AGENCY, after setting up a new delivery of performance schedule, may allow the Contractor to continue work, or treat the termination as a Termination for Convenience.

Opportunity to Cure (General Provision)

The AGENCY, in its sole discretion may, in the case of a termination for breach or default, allow the Contractor [an appropriately short period of time] in which to cure the defect. In such case, the Notice of Termination will state the time period in which cure is permitted and other appropriate conditions

If Contractor fails to remedy to AGENCY's satisfaction the breach or default of any of the terms, covenants, or conditions of this Contract within [10 days] after receipt by Contractor of written notice from AGENCY setting forth the nature of said breach or default, AGENCY shall have the right to terminate the contract without any further obligation to Contractor. Any such termination for default shall not in any way operate to preclude AGENCY from also pursuing all available remedies against Contractor and its sureties for said breach or default.

Waiver of Remedies for any Breach

In the event that AGENCY elects to waive its remedies for any breach by Contractor of any covenant, term or condition of this contract, such waiver by AGENCY shall not limit AGENCY's remedies for any succeeding breach of that or of any other covenant, term, or condition of this contract.

Termination for Convenience (Professional or Transit Service Contracts)

The AGENCY, by written notice, may terminate this contract, in whole or in part, when it is in the AGENCY's interest. If this contract is terminated, the AGENCY shall be liable only for payment under the payment provisions of this contract for services rendered before the effective date of termination.

Termination for Default (Supplies and Service)

If the Contractor fails to deliver supplies or to perform the services within the time specified in this contract or any extension, or if the Contractor fails to comply with any other provisions of this contract, the AGENCY may terminate this contract for default. The AGENCY shall terminate by delivering to the Contractor a Notice of Termination specifying the nature of the default. The Contractor will only be paid the contract price for supplies delivered and accepted, or services performed in accordance with the manner or performance set forth in this contract.

If, after termination for failure to fulfill contract obligations, it is determined that the Contractor was not in default, the rights and obligations of the parties shall be the same as if the termination had been issued for the convenience of the AGENCY.

Termination for Default (Transportation Services)

If the Contractor fails to pick up the commodities or to perform the services, including delivery services, within the time specified in this contract or any extension, or if the Contractor fails to comply with any other provisions of this contract, the AGENCY may terminate this contract for default. The AGENCY shall terminate by delivering to the Contractor a Notice of Termination

specifying the nature of default. The Contractor will only be paid the contract price for services performed in accordance with the manner of performance set forth in this contract.

If this contract is terminated while the Contractor has possession of AGENCY goods, the Contractor shall, upon direction of the AGENCY, protect and preserve the goods until surrendered to the AGENCY or its agent. The Contractor and AGENCY shall agree on payment for the preservation and protection of goods. Failure to agree on an amount will be resolved under the Dispute clause.

If, after termination for failure to fulfill contract obligations, it is determined that the Contractor was not in default, the rights and obligations of the parties shall be the same as if the termination had been issued for the convenience of the AGENCY.

Termination for Default (Construction)

If the Contractor refuses or fails to prosecute the work or any separable part, with the diligence that will ensure its completion within the time specified in this contract or any extension or fails to complete the work within this time, or if the Contractor fails to comply with any other provision of this contract, AGENCY may terminate this contract for default. The AGENCY shall terminate by delivering to the Contractor a Notice of Termination specifying the nature of the default. In this event, the AGENCY may take over the work and complete it by contract or otherwise, and may take possession of and use any materials, appliances, and plant on the work site necessary for completing the work. The Contractor and its sureties shall be liable for any damage to the AGENCY resulting from the Contractor's refusal or failure to complete the work within specified time, whether or not the Contractor's right to proceed with the work is terminated. This liability includes any increased costs incurred by the AGENCY in completing the work.

The Contractor's right to proceed shall not be terminated nor shall the Contractor be charged with damages under this clause if:

1. The delay in completing the work arises from unforeseeable causes beyond the control and without the fault or negligence of the Contractor. Examples of such causes include: acts of God, acts of AGENCY, acts of another contractor in the performance of a contract with AGENCY, epidemics, quarantine restrictions, strikes, freight embargoes; and
2. The Contractor, within [10] days from the beginning of any delay, notifies AGENCY in writing of the causes of delay. If, in the judgment of AGENCY, the delay is excusable, the time for completing the work shall be extended. The judgment of AGENCY shall be final and conclusive for the parties, but subject to appeal under the Disputes clause(s) of this contract.

If, after termination of the Contractor's right to proceed, it is determined that the Contractor was not in default, or that the delay was excusable, the rights and obligations of the parties will be the same as if the termination had been issued for the convenience of AGENCY.

Termination for Convenience or Default (Architect and Engineering)

The AGENCY may terminate this contract in whole or in part, for the AGENCY's convenience or because of the failure of the Contractor to fulfill the contract obligations. The AGENCY shall terminate by delivering to the Contractor a Notice of Termination specifying the nature, extent, and effective date of the termination. Upon receipt of the notice, the Contractor shall (1) immediately discontinue all services affected (unless the notice directs otherwise), and (2) deliver to the AGENCY's Contracting Officer all data, drawings, specifications, reports, estimates, summaries, and other information and materials accumulated in performing this contract, whether completed or in process. AGENCY has a royalty-free, nonexclusive, and irrevocable license to reproduce, publish or otherwise use, all such data, drawings, specifications, reports, estimates, summaries, and other information and materials.

If the termination is for the convenience of the AGENCY, the AGENCY's Contracting Officer shall make an equitable adjustment in the contract price but shall allow no anticipated profit on unperformed services.

If the termination is for failure of the Contractor to fulfill the contract obligations, the AGENCY may complete the work by contract or otherwise and the Contractor shall be liable for any additional cost incurred by the AGENCY.

If, after termination for failure to fulfill contract obligations, it is determined that the Contractor was not in default, the rights and obligations of the parties shall be the same as if the termination had been issued for the convenience of AGENCY.

Termination for Convenience or Default (Cost-Type Contracts)

The AGENCY may terminate this contract, or any portion of it, by serving a Notice of Termination on the Contractor. The notice shall state whether the termination is for convenience of AGENCY or for the default of the Contractor. If the termination is for default, the notice shall state the manner in which the Contractor has failed to perform the requirements of the contract. The Contractor shall account for any property in its possession paid for from funds received from the AGENCY, or property supplied to the Contractor by the AGENCY. If the termination is for default, the AGENCY may fix the fee, if the contract provides for a fee, to be paid the Contractor in proportion to the value, if any, of work performed up to the time of termination. The Contractor shall promptly submit its termination claim to the AGENCY and the parties shall negotiate the termination settlement to be paid the Contractor.

If the termination is for the convenience of AGENCY, the Contractor shall be paid its contract close-out costs, and a fee, if the contract provided for payment of a fee, in proportion to the work performed up to the time of termination.

If, after serving a Notice of Termination for Default, the AGENCY determines that the Contractor

has an excusable reason for not performing, the AGENCY, after setting up a new work schedule, may allow the Contractor to continue work, or treat the termination as a Termination for Convenience.

VETERANS EMPLOYMENT

FTA Circular 4220.1F (Chapter IV) 49 USC §5325(K)

Applicability to Contracts The Veterans Employment provisions apply to all construction contracts.

Veterans Employment.

Recipients and subrecipients of Federal financial assistance under this chapter shall ensure that contractors working on a capital project funded using such assistance give a hiring preference, to the extent practicable, to veterans (as defined in section 2108 of title 5) who have the requisite skills and abilities to perform the construction work required under the contract. This subsection shall not be understood, construed or enforced in any manner that would require an employer to give preference to any veteran over any equally qualified applicant who is a member of any racial or ethnic minority, female, an individual with a disability, or former employee.

VIOLATION AND BREACH OF CONTRACT

>\$250,000

2 C.F.R. § 200.326

2 C.F.R. part 200, Appendix II (A)

Applicability to Contracts

All contracts in excess of the Simplified Acquisition Threshold (currently set at \$150,000) shall contain administrative, contractual, or legal remedies in instances where contractors violate or breach contract terms, and provide for such sanctions and penalties as appropriate.

Flow Down

The Violations and Breach of Contracts clause flow down to all third party contractors and their contracts at every tier.

Clauses Language

FTA does not prescribe the form or content of such provisions. The provisions developed will depend on the circumstances and the type of contract. Recipients should consult legal counsel in developing appropriate clauses. The following clauses are examples of provisions from various FTA third party contracts. Recipients can draw on these examples for inclusion in their federally funded procurements.

Rights and Remedies of the AGENCY

The AGENCY shall have the following rights in the event that the AGENCY deems the Contractor guilty of a breach of any term under the Contract.

1. The right to take over and complete the work or any part thereof as agency for and at the expense of the Contractor, either directly or through other contractors;
2. The right to cancel this Contract as to any or all of the work yet to be performed;
3. The right to specific performance, an injunction or any other appropriate equitable remedy; and
4. The right to money damages.

For purposes of this Contract, breach shall include [AGENCY to define].

Rights and Remedies of Contractor

Inasmuch as the Contractor can be adequately compensated by money damages for any breach of this Contract, which may be committed by the AGENCY, the Contractor expressly agrees that no default, act or omission of the AGENCY shall constitute a material breach of this Contract, entitling Contractor to cancel or rescind the Contract (unless the AGENCY directs Contractor to do so) or to suspend or abandon performance.

Remedies

Substantial failure of the Contractor to complete the Project in accordance with the terms of this Agreement will be a default of this Agreement. In the event of a default, the AGENCY will have all remedies in law and equity, including the right to specific performance, without further assistance, and the rights to termination or suspension as provided herein. The Contractor recognizes that in the event of a breach of this Agreement by the Contractor before the AGENCY takes action contemplated herein, the AGENCY will provide the Contractor with sixty (60) days written notice that the AGENCY considers that such a breach has occurred and will provide the Contractor a reasonable period of time to respond and to take necessary corrective action.

Disputes

- Example 1: Disputes arising in the performance of this Contract that are not resolved by agreement of the parties shall be decided in writing by the authorized representative of AGENCY's [title of employee]. This decision shall be final and conclusive unless within [10] days from the date of receipt of its copy, the Contractor mails or otherwise furnishes a written appeal to the [title of employee]. In connection with any such appeal, the Contractor shall be afforded an opportunity to be heard and to offer evidence in support of its position. The decision of the [title of employee] shall be binding upon the Contractor and the Contractor shall abide by the decision.
- Example 2: The AGENCY and the Contractor intend to resolve all disputes under this Agreement to the best of their abilities in an informal manner. To accomplish this end, the parties will use an Alternative Dispute Resolution process to resolve disputes in a manner designed to avoid litigation. In general, the parties contemplate that the Alternative Dispute Resolution process will include, at a minimum, an attempt to resolve disputes through communications between their staffs, and, if resolution is not reached at that level, a procedure for review and action on such disputes by appropriate management level officials within the AGENCY and the Contractor's organization.

In the event that a resolution of the dispute is not mutually agreed upon, the parties can agree to mediate the dispute or proceed with litigation. Notwithstanding any provision of this section, or any other provision of this Contract, it is expressly agreed and understood that any court proceeding arising out of a dispute under the Contract shall be heard by a Court de novo and the court shall not be limited in such proceeding to the issue of whether the Authority acted in an arbitrary, capricious or grossly erroneous manner.

Pending final settlement of any dispute, the parties shall proceed diligently with the performance of the Contract, and in accordance with the AGENCY's direction or decisions made thereof.

Performance during Dispute

Unless otherwise directed by AGENCY, Contractor shall continue performance under this Contract while matters in dispute are being resolved.

Claims for Damages

Should either party to the Contract suffer injury or damage to person or property because of any act or omission of the party or of any of its employees, agents or others for whose acts it is legally liable, a claim for damages therefore shall be made in writing to such other party within a reasonable time after the first observance of such injury or damage.

Remedies

Unless this Contract provides otherwise, all claims, counterclaims, disputes and other matters in question between the AGENCY and the Contractor arising out of or relating to this agreement or its breach will be decided by arbitration if the parties mutually agree, or in a court of competent jurisdiction within the State in which the AGENCY is located.

Rights and Remedies

The duties and obligations imposed by the Contract documents and the rights and remedies available thereunder shall be in addition to and not a limitation of any duties, obligations, rights and remedies otherwise imposed or available by law. No action or failure to act by the AGENCY or Contractor shall constitute a waiver of any right or duty afforded any of them under the Contract, nor shall any such action or failure to act constitute an approval of or acquiescence in any breach thereunder, except as may be specifically agreed in writing.

Appendix C - DBE and Davis-Bacon Determination

Memorandum

DATE: February 15, 2024

TO: Marti Hoge

FROM: Tori Berry
Civil Rights Manager

SUBJECT: Project CP0025
Project description- Park City Bus Stops

DBE GOAL: 0.16%

DAVIS BACON WAGE RATES "ARE" REQUIRED

Your attention to the DBE goal is appreciated. This memo is valid for 6 months or if changes are made to scope of work, it will need to be resubmitted to Civil Rights for revision.

"General Decision Number: UT20240079 01/19/2024

Superseded General Decision Number: UT20230079

State: Utah

Construction Type: Building

Counties: Daggett, Duchesne, Rich and Summit Counties in Utah.

BUILDING CONSTRUCTION PROJECTS (does not include single family homes or apartments up to and including 4 stories).

Note: Contracts subject to the Davis-Bacon Act are generally required to pay at least the applicable minimum wage rate required under Executive Order 14026 or Executive Order 13658. Please note that these Executive Orders apply to covered contracts entered into by the federal government that are subject to the Davis-Bacon Act itself, but do not apply to contracts subject only to the Davis-Bacon Related Acts, including those set forth at 29 CFR 5.1(a)(1).

<p>If the contract is entered into on or after January 30, 2022, or the contract is renewed or extended (e.g., an option is exercised) on or after January 30, 2022:</p>	<ul style="list-style-type: none"> . Executive Order 14026 generally applies to the contract. . The contractor must pay all covered workers at least \$17.20 per hour (or the applicable wage rate listed on this wage determination, if it is higher) for all hours spent performing on the contract in 2024.
<p>If the contract was awarded on or between January 1, 2015 and January 29, 2022, and the contract is not renewed or extended on or after January 30, 2022:</p>	<ul style="list-style-type: none"> . Executive Order 13658 generally applies to the contract. . The contractor must pay all covered workers at least \$12.90 per hour (or the applicable wage rate listed on this wage determination, if it is higher) for all hours spent performing on that contract in 2024.

The applicable Executive Order minimum wage rate will be adjusted annually. If this contract is covered by one of the Executive Orders and a classification considered necessary for performance of work on the contract does not appear on this wage determination, the contractor must still submit a conformance request.

Additional information on contractor requirements and worker protections under the Executive Orders is available at <http://www.dol.gov/whd/govcontracts>.

Modification Number Publication Date
 0 01/05/2024

1

01/19/2024

BOIL0004-001 01/01/2021

	Rates	Fringes
BOILERMAKER.....	\$ 35.12	31.54

ELEC0354-001 06/11/2023

	Rates	Fringes
ELECTRICIAN (Low Voltage Wiring Only).....	\$ 27.65	14.73+1.5%
ELECTRICIAN.....	\$ 39.00	1.3%+16.55

* SFUT0669-003 01/01/2024

	Rates	Fringes
SPRINKLER FITTER (Fire Sprinklers).....	\$ 38.17	25.54

SHEE0312-001 07/01/2022

	Rates	Fringes
SHEET METAL WORKER (HVAC Duct Installation Only).....	\$ 39.26	11.67

* SUUT2012-011 07/29/2014

	Rates	Fringes
BRICKLAYER.....	\$ 23.88	0.00
CARPENTER (Acoustical Ceiling Installation Only).....	\$ 21.72	1.43
CARPENTER, Excludes Acoustical Ceiling Installation.....	\$ 19.51	5.30
CEMENT MASON/CONCRETE FINISHER...	\$ 21.11	0.00
INSULATOR - BATT.....	\$ 12.50 **	0.23
IRONWORKER, REINFORCING.....	\$ 15.00 **	0.00
IRONWORKER, STRUCTURAL.....	\$ 17.41	6.13
LABORER: Common or General.....	\$ 13.98 **	0.00
LABORER: Mason Tender - Brick...	\$ 16.54 **	0.00
OPERATOR: Backhoe/Excavator/Trackhoe.....	\$ 16.59 **	0.79
PLUMBER.....	\$ 24.00	4.62
TILE FINISHER.....	\$ 17.00 **	0.00
TILE SETTER.....	\$ 20.63	0.00

WELDERS - Receive rate prescribed for craft performing operation to which welding is incidental.

=====
** Workers in this classification may be entitled to a higher minimum wage under Executive Order 14026 (\$17.20) or 13658 (\$12.90). Please see the Note at the top of the wage determination for more information. Please also note that the minimum wage requirements of Executive Order 14026 are not currently being enforced as to any contract or subcontract to which the states of Texas, Louisiana, or Mississippi, including their agencies, are a party.

Note: Executive Order (EO) 13706, Establishing Paid Sick Leave for Federal Contractors applies to all contracts subject to the Davis-Bacon Act for which the contract is awarded (and any solicitation was issued) on or after January 1, 2017. If this contract is covered by the EO, the contractor must provide employees with 1 hour of paid sick leave for every 30 hours they work, up to 56 hours of paid sick leave each year. Employees must be permitted to use paid sick leave for their own illness, injury or other health-related needs, including preventive care; to assist a family member (or person who is like family to the employee) who is ill, injured, or has other health-related needs, including preventive care; or for reasons resulting from, or to assist a family member (or person who is like family to the employee) who is a victim of, domestic violence, sexual assault, or stalking. Additional information on contractor requirements and worker protections under the EO is available at <https://www.dol.gov/agencies/whd/government-contracts>.

Unlisted classifications needed for work not included within the scope of the classifications listed may be added after award only as provided in the labor standards contract clauses (29CFR 5.5 (a) (1) (iii)).

The body of each wage determination lists the classification and wage rates that have been found to be prevailing for the cited type(s) of construction in the area covered by the wage determination. The classifications are listed in alphabetical order of ""identifiers"" that indicate whether the particular rate is a union rate (current union negotiated rate for local), a survey rate (weighted average rate) or a union average rate (weighted union average rate).

Union Rate Identifiers

A four letter classification abbreviation identifier enclosed in dotted lines beginning with characters other than ""SU"" or ""UAVG"" denotes that the union classification and rate were prevailing for that classification in the survey. Example: PLUM0198-005 07/01/2014. PLUM is an abbreviation identifier of the union which prevailed in the survey for this classification, which in this example would be Plumbers. 0198 indicates the local union number or district council number where applicable, i.e., Plumbers Local 0198. The next number, 005 in the example, is an internal number used in processing the wage determination. 07/01/2014 is the effective date of the most current negotiated rate, which in this example is July 1,

2014.

Union prevailing wage rates are updated to reflect all rate changes in the collective bargaining agreement (CBA) governing this classification and rate.

Survey Rate Identifiers

Classifications listed under the "SU" identifier indicate that no one rate prevailed for this classification in the survey and the published rate is derived by computing a weighted average rate based on all the rates reported in the survey for that classification. As this weighted average rate includes all rates reported in the survey, it may include both union and non-union rates. Example: SULA2012-007 5/13/2014. SU indicates the rates are survey rates based on a weighted average calculation of rates and are not majority rates. LA indicates the State of Louisiana. 2012 is the year of survey on which these classifications and rates are based. The next number, 007 in the example, is an internal number used in producing the wage determination. 5/13/2014 indicates the survey completion date for the classifications and rates under that identifier.

Survey wage rates are not updated and remain in effect until a new survey is conducted.

Union Average Rate Identifiers

Classification(s) listed under the UAVG identifier indicate that no single majority rate prevailed for those classifications; however, 100% of the data reported for the classifications was union data. EXAMPLE: UAVG-OH-0010 08/29/2014. UAVG indicates that the rate is a weighted union average rate. OH indicates the state. The next number, 0010 in the example, is an internal number used in producing the wage determination. 08/29/2014 indicates the survey completion date for the classifications and rates under that identifier.

A UAVG rate will be updated once a year, usually in January of each year, to reflect a weighted average of the current negotiated/CBA rate of the union locals from which the rate is based.

WAGE DETERMINATION APPEALS PROCESS

1.) Has there been an initial decision in the matter? This can be:

- * an existing published wage determination
- * a survey underlying a wage determination
- * a Wage and Hour Division letter setting forth a position on a wage determination matter
- * a conformance (additional classification and rate) ruling

On survey related matters, initial contact, including requests for summaries of surveys, should be with the Wage and Hour National Office because National Office has responsibility for the Davis-Bacon survey program. If the response from this initial contact is not satisfactory, then the process described in 2.) and 3.) should be followed.

With regard to any other matter not yet ripe for the formal process described here, initial contact should be with the Branch of Construction Wage Determinations. Write to:

Branch of Construction Wage Determinations
Wage and Hour Division
U.S. Department of Labor
200 Constitution Avenue, N.W.
Washington, DC 20210

2.) If the answer to the question in 1.) is yes, then an interested party (those affected by the action) can request review and reconsideration from the Wage and Hour Administrator (See 29 CFR Part 1.8 and 29 CFR Part 7). Write to:

Wage and Hour Administrator
U.S. Department of Labor
200 Constitution Avenue, N.W.
Washington, DC 20210

The request should be accompanied by a full statement of the interested party's position and by any information (wage payment data, project description, area practice material, etc.) that the requestor considers relevant to the issue.

3.) If the decision of the Administrator is not favorable, an interested party may appeal directly to the Administrative Review Board (formerly the Wage Appeals Board). Write to:

Administrative Review Board
U.S. Department of Labor
200 Constitution Avenue, N.W.
Washington, DC 20210

4.) All decisions by the Administrative Review Board are final.

=====

END OF GENERAL DECISION"

"General Decision Number: UT20240100 01/05/2024

Superseded General Decision Number: UT20230100

State: Utah

Construction Type: Highway

County: Summit County in Utah.

HIGHWAY CONSTRUCTION PROJECTS

Note: Contracts subject to the Davis-Bacon Act are generally required to pay at least the applicable minimum wage rate required under Executive Order 14026 or Executive Order 13658. Please note that these Executive Orders apply to covered contracts entered into by the federal government that are subject to the Davis-Bacon Act itself, but do not apply to contracts subject only to the Davis-Bacon Related Acts, including those set forth at 29 CFR 5.1(a)(1).

<p>If the contract is entered into on or after January 30, 2022, or the contract is renewed or extended (e.g., an option is exercised) on or after January 30, 2022:</p>	<ul style="list-style-type: none"> ◆ Executive Order 14026 generally applies to the contract. ◆ The contractor must pay all covered workers at least \$17.20 per hour (or the applicable wage rate listed on this wage determination, if it is higher) for all hours spent performing on the contract in 2024.
<p>If the contract was awarded on or between January 1, 2015 and January 29, 2022, and the contract is not renewed or extended on or after January 30, 2022:</p>	<ul style="list-style-type: none"> ◆ Executive Order 13658 generally applies to the contract. ◆ The contractor must pay all covered workers at least \$12.90 per hour (or the applicable wage rate listed on this wage determination, if it is higher) for all hours performing on that contract in 2024.

The applicable Executive Order minimum wage rate will be adjusted annually. If this contract is covered by one of the Executive Orders and a classification considered necessary for performance of work on the contract does not appear on this wage determination, the contractor must still submit a conformance request.

Additional information on contractor requirements and worker protections under the Executive Orders is available at <http://www.dol.gov/whd/govcontracts>.

Modification Number Publication Date
 0 01/05/2024

SUUT2019-012 04/03/2023

	Rates	Fringes
CARPENTER, Includes Form Work....	\$ 21.93	3.48
CEMENT MASON/CONCRETE FINISHER...	\$ 21.26	2.87
ELECTRICIAN.....	\$ 26.83	0.00
FENCE ERECTOR.....	\$ 15.86 **	2.84
HIGHWAY/PARKING LOT STRIPING:		
Painter.....	\$ 19.26	1.62
INSTALLER - SIGN.....	\$ 17.48	2.73
LABORER: Asphalt, Includes Raker, Shoveler, Spreader and Distributor.....	\$ 24.66	8.65
LABORER: Common or General.....	\$ 17.41	2.77
LABORER: Landscape.....	\$ 15.16 **	2.79
LABORER: Mason Tender - Cement/Concrete.....	\$ 16.62 **	2.71
LABORER: Pipelayer.....	\$ 18.04	2.79
OPERATOR: Backhoe/Excavator/Trackhoe.....	\$ 23.01	6.88
OPERATOR: Bobcat/Skid Steer/Skid Loader.....	\$ 20.05	3.31
OPERATOR: Broom/Sweeper.....	\$ 20.28	7.41
OPERATOR: Bulldozer.....	\$ 24.21	1.59
OPERATOR: Concrete Finishing Machine.....	\$ 22.57	6.55
OPERATOR: Grader/Blade.....	\$ 27.92	15.65
OPERATOR: Loader.....	\$ 25.37	15.65
OPERATOR: Mechanic.....	\$ 27.43	15.65
OPERATOR: Milling Machine.....	\$ 27.81	7.26
OPERATOR: Oiler.....	\$ 19.00	5.44
OPERATOR: Paver (Asphalt, Aggregate, and Concrete).....	\$ 24.37	15.65
OPERATOR: Roller.....	\$ 27.66	11.03
OPERATOR: Screed.....	\$ 26.14	12.31
TRAFFIC CONTROL: Flagger.....	\$ 15.00 **	4.13
TRAFFIC CONTROL: Laborer-Cones/ Barricades/Barrels - Setter/Mover/Sweeper.....	\$ 22.77	8.65

TRUCK DRIVER: Dump Truck.....\$ 22.32	9.09
TRUCK DRIVER: Oil Distributor Truck.....\$ 27.34	8.55
TRUCK DRIVER: Water Truck.....\$ 22.44	11.51

WELDERS - Receive rate prescribed for craft performing operation to which welding is incidental.

=====
** Workers in this classification may be entitled to a higher minimum wage under Executive Order 14026 (\$17.20) or 13658 (\$12.90). Please see the Note at the top of the wage determination for more information. Please also note that the minimum wage requirements of Executive Order 14026 are not currently being enforced as to any contract or subcontract to which the states of Texas, Louisiana, or Mississippi, including their agencies, are a party.

Note: Executive Order (EO) 13706, Establishing Paid Sick Leave for Federal Contractors applies to all contracts subject to the Davis-Bacon Act for which the contract is awarded (and any solicitation was issued) on or after January 1, 2017. If this contract is covered by the EO, the contractor must provide employees with 1 hour of paid sick leave for every 30 hours they work, up to 56 hours of paid sick leave each year. Employees must be permitted to use paid sick leave for their own illness, injury or other health-related needs, including preventive care; to assist a family member (or person who is like family to the employee) who is ill, injured, or has other health-related needs, including preventive care; or for reasons resulting from, or to assist a family member (or person who is like family to the employee) who is a victim of, domestic violence, sexual assault, or stalking. Additional information on contractor requirements and worker protections under the EO is available at <https://www.dol.gov/agencies/whd/government-contracts>.

Unlisted classifications needed for work not included within the scope of the classifications listed may be added after award only as provided in the labor standards contract clauses (29CFR 5.5 (a) (1) (iii)).

The body of each wage determination lists the classification and wage rates that have been found to be prevailing for the cited type(s) of construction in the area covered by the wage determination. The classifications are listed in alphabetical order of ""identifiers"" that indicate whether the particular rate is a union rate (current union negotiated rate for local), a survey rate (weighted average rate) or a union average rate (weighted union average rate).

Union Rate Identifiers

A four letter classification abbreviation identifier enclosed in dotted lines beginning with characters other than ""SU"" or ""UAVG"" denotes that the union classification and rate were prevailing for that classification in the survey. Example:

PLUM0198-005 07/01/2014. PLUM is an abbreviation identifier of the union which prevailed in the survey for this classification, which in this example would be Plumbers. 0198 indicates the local union number or district council number where applicable, i.e., Plumbers Local 0198. The next number, 005 in the example, is an internal number used in processing the wage determination. 07/01/2014 is the effective date of the most current negotiated rate, which in this example is July 1, 2014.

Union prevailing wage rates are updated to reflect all rate changes in the collective bargaining agreement (CBA) governing this classification and rate.

Survey Rate Identifiers

Classifications listed under the "SU" identifier indicate that no one rate prevailed for this classification in the survey and the published rate is derived by computing a weighted average rate based on all the rates reported in the survey for that classification. As this weighted average rate includes all rates reported in the survey, it may include both union and non-union rates. Example: SULA2012-007 5/13/2014. SU indicates the rates are survey rates based on a weighted average calculation of rates and are not majority rates. LA indicates the State of Louisiana. 2012 is the year of survey on which these classifications and rates are based. The next number, 007 in the example, is an internal number used in producing the wage determination. 5/13/2014 indicates the survey completion date for the classifications and rates under that identifier.

Survey wage rates are not updated and remain in effect until a new survey is conducted.

Union Average Rate Identifiers

Classification(s) listed under the UAVG identifier indicate that no single majority rate prevailed for those classifications; however, 100% of the data reported for the classifications was union data. EXAMPLE: UAVG-OH-0010 08/29/2014. UAVG indicates that the rate is a weighted union average rate. OH indicates the state. The next number, 0010 in the example, is an internal number used in producing the wage determination. 08/29/2014 indicates the survey completion date for the classifications and rates under that identifier.

A UAVG rate will be updated once a year, usually in January of each year, to reflect a weighted average of the current negotiated/CBA rate of the union locals from which the rate is based.

WAGE DETERMINATION APPEALS PROCESS

1.) Has there been an initial decision in the matter? This can be:

- * an existing published wage determination
- * a survey underlying a wage determination
- * a Wage and Hour Division letter setting forth a position on a wage determination matter
- * a conformance (additional classification and rate) ruling

On survey related matters, initial contact, including requests for summaries of surveys, should be with the Wage and Hour National Office because National Office has responsibility for the Davis-Bacon survey program. If the response from this initial contact is not satisfactory, then the process described in 2.) and 3.) should be followed.

With regard to any other matter not yet ripe for the formal process described here, initial contact should be with the Branch of Construction Wage Determinations. Write to:

Branch of Construction Wage Determinations
Wage and Hour Division
U.S. Department of Labor
200 Constitution Avenue, N.W.
Washington, DC 20210

2.) If the answer to the question in 1.) is yes, then an interested party (those affected by the action) can request review and reconsideration from the Wage and Hour Administrator (See 29 CFR Part 1.8 and 29 CFR Part 7). Write to:

Wage and Hour Administrator
U.S. Department of Labor
200 Constitution Avenue, N.W.
Washington, DC 20210

The request should be accompanied by a full statement of the interested party's position and by any information (wage payment data, project description, area practice material, etc.) that the requestor considers relevant to the issue.

3.) If the decision of the Administrator is not favorable, an interested party may appeal directly to the Administrative Review Board (formerly the Wage Appeals Board). Write to:

Administrative Review Board
U.S. Department of Labor
200 Constitution Avenue, N.W.
Washington, DC 20210

4.) All decisions by the Administrative Review Board are final.

=====

END OF GENERAL DECISION"