

## **STREET DINING ON MAIN OUTDOOR DINING LEASE 2023**

This Street Dining on Main Outdoor Dining Lease 2023 (the "Lease" or "Agreement") is made and executed this 13<sup>th</sup> day of June, 2023, by and between **PARK CITY MUNICIPAL CORPORATION**, a Utah municipal corporation, (the "City", "Park City", or "Landlord") and **SHABU, INC.**, a Utah corporation, (the "Tenant") located at 442 Main Street, Park City, Utah.

### *RECITALS*

WHEREAS, the City wishes to enable opportunities for restaurants on Main Street to be able to provide additional outdoor dining opportunities; and

WHEREAS, the City's goals include the establishment of new and creative opportunities to facilitate the Main Street experience for residents and visitors alike during the shoulder and summer seasons; and

WHEREAS, the City's goals include the preservation and enhancement of Park City's character regarding Old Town and the desire to strengthen the pedestrian experience along Main Street; and

WHEREAS, the City recognizes the desire of many visitors and residents to dine outdoors along historic Main Street; and

WHEREAS, the City's General Plan recommends utilizing street design techniques to encourage slower traffic speeds and a more intimate pedestrian-oriented scale; and

WHEREAS, the City's goals include maintaining and furthering the resort community's economic opportunities, as well as enhancing the economic viability of Park City's Main Street Business District.

NOW, THEREFORE, BE IT ORDAINED by the City Council of Park City, Utah as follows:

### *TERMS & CONDITIONS OF LEASE*

Based upon good and valuable mutual consideration, the Parties agree as follows:

1. **PROPERTY.** The property affected by this Lease is generally described as the street area and sidewalk directly fronting Tenant's building located at 442 Main Street, which has a length of 23.7 feet (1.18 # of parking spaces), and more specifically described in site plan **Exhibit A**, attached hereto and incorporated

herein by this reference, (the "Premises"). The length of the outdoor dining deck per restaurant may not exceed forty feet (40').

2. RENT. Annual rent for the use of the street for the deck is TWO THOUSAND ONE HUNDRED SIXTY DOLLARS (\$2,160.00) per parking space of a linear length of 20 feet. The rent total is **TWO THOUSAND FIVE HUNDRED FORTY EIGHT DOLLARS AND EIGHTY CENTS (\$2,548.80)**. This rent is for 2023 only. Tenant shall be solely responsible for payment of any and all costs associated with Tenant's performance under this Lease, including but not limited to additional business licensing fees, insurance, sales taxes and other expenses.
3. TERM. Unless otherwise delayed, suspended, or terminated by Summit County health order(s), the term of this Agreement shall commence on June 27, 2023, and shall terminate on October 1, 2023 ("Term") unless terminated earlier as provided herein. The Premises may only be utilized for a six (6) month period commencing on June 27, 2023, and terminating on October 30, 2023, except the Premises may not be used during the 2023 Kimball Arts Festival (August 4, 2023, through August 6, 2023) unless Kimball Art Center consents in writing to allow Tenant to use the Premises. Additional term restrictions are attached hereto and incorporated herein by this reference in **Exhibit B** (Street Dining Operational Restrictions). This Agreement may be terminated by Park City upon a finding of non-compliance of this Agreement or the attached operational restrictions.

The use of the Premises shall not conflict with any previously existing Special Event recipients on Main Street, specifically the Arts Fest ("Kimball Art Center"). The Kimball Art Center has been leased exclusive use of Main Street in August. The Premises must be vacated (i.e., removal of decks) no later than 10:00 a.m. MT on Thursday, August 3, 2023, for the duration of Arts Fest (including set-up and breakdown) unless the Kimball Art Center consents in writing to allow Tenant's use of the Premises. If the outdoor dining structure is not removed as required, the Landlord will remove the structure at Tenant's cost. **The dates of the 2023 Kimball Arts Festival are subject to change, and as such the vacating of the Premises shall occur at 10:00 a.m. the day prior to the Arts Fest.**

4. MAIN STREET IMPROVEMENTS. If at any time the street dining deck needs to be removed due to construction related to Main Street improvements, the City will give each affected street dining business owner a minimum of seventy two (72) hours to have their decks removed. The City will not be responsible for any associated costs involving deck removal/placement or potential lost revenue.
5. USE OF PREMISES. Tenant may use the Premises only for outdoor dining services in a manner consistent with applicable Summit County health orders, Section 15-2.6-12(B)(1) of the Park City Land Management Code and the terms of this Agreement. Additional operational restrictions which must be complied

with as part of the conditions of this Lease are attached hereto and incorporated herein in **Exhibit B**. Park City makes no representations regarding the Premises and Tenant accepts the Premises "AS IS."

6. **IMPROVEMENTS TO THE PREMISES.** Tenant shall not make any improvements to the Premises without first obtaining Park City's written consent. Any improvements approved by Park City shall be completed at Tenant's sole expense and removed at Tenant's sole expense upon expiration of this Agreement. No permanent alterations to the City's property are permitted.
7. **SIGNS.** No signs shall be permitted on the Premises except as specifically approved by the Park City Municipal Corporation Planning Department pursuant to the Park City Sign Code and/or Tenant's Master Sign Plan.
8. **INSURANCE.** Tenant shall, at Tenant's sole expense, carry a policy of general liability insurance in an amount of at least Two Million Dollars (\$2,000,000) per combined single limit per occurrence and Three Million Dollars (\$3,000,000) per aggregate for personal injury, bodily injury and property damage. Park City shall be named as an additional insured by endorsement on each policy. Tenant's insurance is to be primary to Park City's and Park City's insurance shall be non-contributory. A certificate of insurance naming Park City as an additional insured shall be provided to Park City on or before the Lease commencement. Insurance shall be maintained continuously during the term of the Lease and should any of the above described policies be cancelled before the expiration date thereof, Tenant shall deliver notice to Park City within thirty (30) days of cancellation. Tenant may carry whatever other insurance Tenant deems appropriate. The parties agree that Tenant's sole remedy in the event of business interruptions, fire, windstorm, or other loss from hazard shall be its own insurance and Tenant will have no action against Park City. Park City is protected by the Utah Governmental Immunity Act, and nothing herein is intended to waive or limit the protection of the Act on behalf of either entity, but to the extent it is consistent with this intent, it is the purpose of this provision to protect Park City for liability or allegations arising out of the Tenant's use of the Premises.
9. **HOLD HARMLESS.** Tenant covenants and agrees to defend, indemnify, and hold Park City harmless from all claims, loss, damage, injury or liability (hereafter "Liability") resulting from Tenant's use and occupancy of the Premises to the full extent permitted by law and/or the Utah Governmental Immunity Act, including reasonable attorney's fees, but excluding any liability resulting from acts or omissions of Park City, its officers, employees or agents. Nothing herein shall be construed as a waiver of any of the rights or defenses under the Utah Governmental Immunity Act (Utah Code Ann. Sections 63-30-1, et seq.), as amended. The obligations hereunder shall be determined under principles of tort law including, but not limited to, the Governmental Immunity Act. In case of an emergency including but not limited to a flood, storm drain, or utility, the structure may be removed or damaged by response teams at the cost of the Tenant.

Tenant shall indemnify, protect and hold the Landlord harmless from and defend (by counsel reasonably acceptable to Landlord) the Landlord against any and all claims, causes of action, liability, damage, loss or expense (including reasonable attorneys' fees and costs and court costs), statutory or otherwise arising out of or incurred in connection with (i) the use, operation, occupancy or existence of the Premises or the presence of visitors, or any other person, at the Premises during the Term, (ii) any activity, work or thing done or permitted or suffered by Tenant in or about the Premises, (iii) any acts, omissions or negligence of Tenant, any person claiming through Tenant, or the contractors, agents, employees, members of the public, invitees, or visitors of Tenant or any other such person ("Tenant Party" or "Tenant Parties"), (iv) any breach, violation or nonperformance by any Tenant Party of any provision of this Lease or of any law of any kind, or (v) except to the extent resulting from any negligence or intentional torts of Landlord.

10. ASSIGNABILITY. Tenant shall not assign or transfer any interest in this Agreement without the prior written consent of Park City. Any assignment or transfer without written approval is void.
11. PROFESSIONAL PERFORMANCE. Tenant agrees to perform services under this Agreement at the highest professional standards, and to the satisfaction of Park City.
12. COUNTERPARTS. This Agreement may be executed in counterparts, each of which will be deemed an original and all of which together will constitute one and the same instrument.
13. ELECTRONIC SIGNATURES. Each party agrees that the signatures of the parties included in this Agreement, whether affixed on an original document manually and later electronically transmitted or whether affixed by an electronic signature through an electronic signature system such as DocuSign, are intended to authenticate this writing and to create a legal and enforceable agreement between the parties hereto.
14. APPLICABLE LAW. This Agreement shall be governed by the laws of the state of Utah.
15. ENTIRE AGREEMENT. This Agreement constitutes the entire and only agreement between the parties and it cannot be altered or amended except by written instrument, signed by both parties.

Executed the day and year first above written.

**LANDLORD:**  
**PARK CITY MUNICIPAL CORPORATION,**  
a Utah municipal corporation

DocuSigned by:  
By: Nann Worel  
Nann Worel, Mayor

Attest:

DocuSigned by:  
   
City Recorder's Office

Approved as to form:

DocuSigned by:  
Mark Harrington  
City Attorney's Office

**TENANT:**  
**SHABU INC.,**  
a Utah corporation

By: DocuSigned by:  
*Kevin Valaika*

57c376037bf2456...  
Name Printed: kevin valaika

Title: owner

THE CITY REQUIRES THE TENANT TO COMPLETE EITHER THE NOTARY BLOCK  
OR THE UNSWORN DECLARATION, WHICH ARE BELOW.

**ACKNOWLEDGMENT**

STATE OF UTAH            )  
  ) ss.  
COUNTY OF SUMMIT    )

On this \_\_\_\_\_ day of \_\_\_\_\_, 2023, personally appeared before me \_\_\_\_\_, who being duly sworn, did say that he/she is the \_\_\_\_\_ of **SHABU, INC.**, a Utah corporation, and acknowledged to me that the preceding Agreement was signed on behalf of the company, and he/she acknowledged that the company did execute the same for its stated purpose.

\_\_\_\_\_  
Notary Public

I declare under criminal penalty under the law of Utah that the foregoing is true and correct.  
Signed on the June day of 9, 2023, at  
Utah Summit County (insert State and County here).

Printed name Kevin Valaika

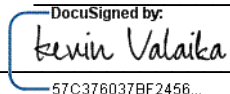
Signature:   
57C376037BF2456...



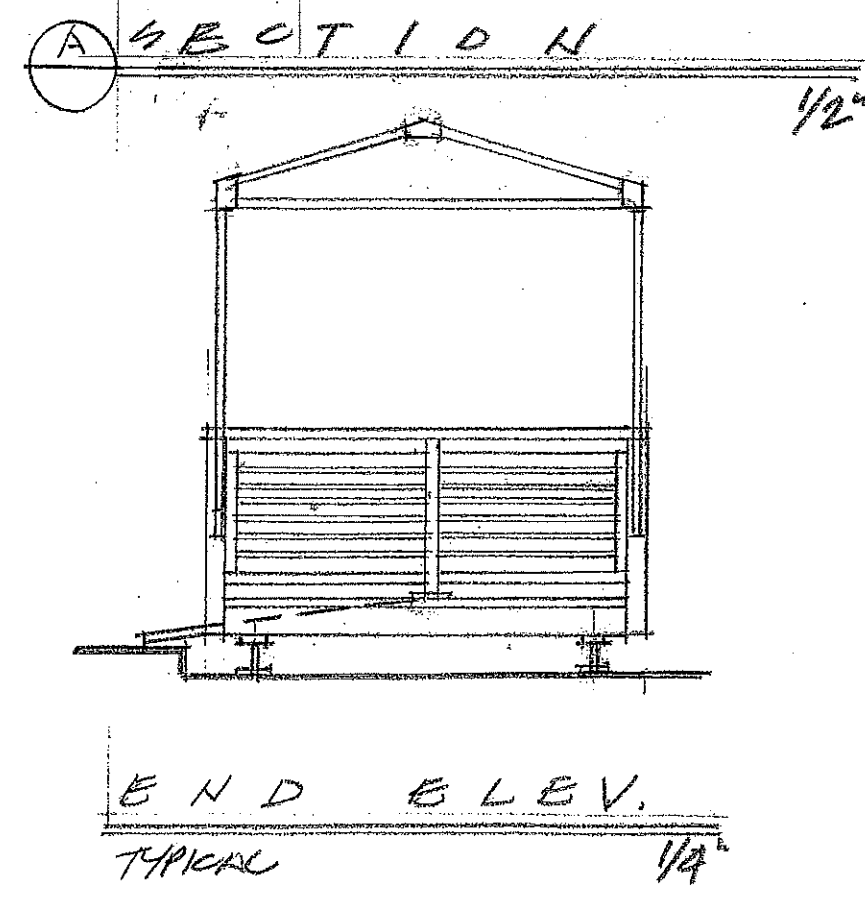
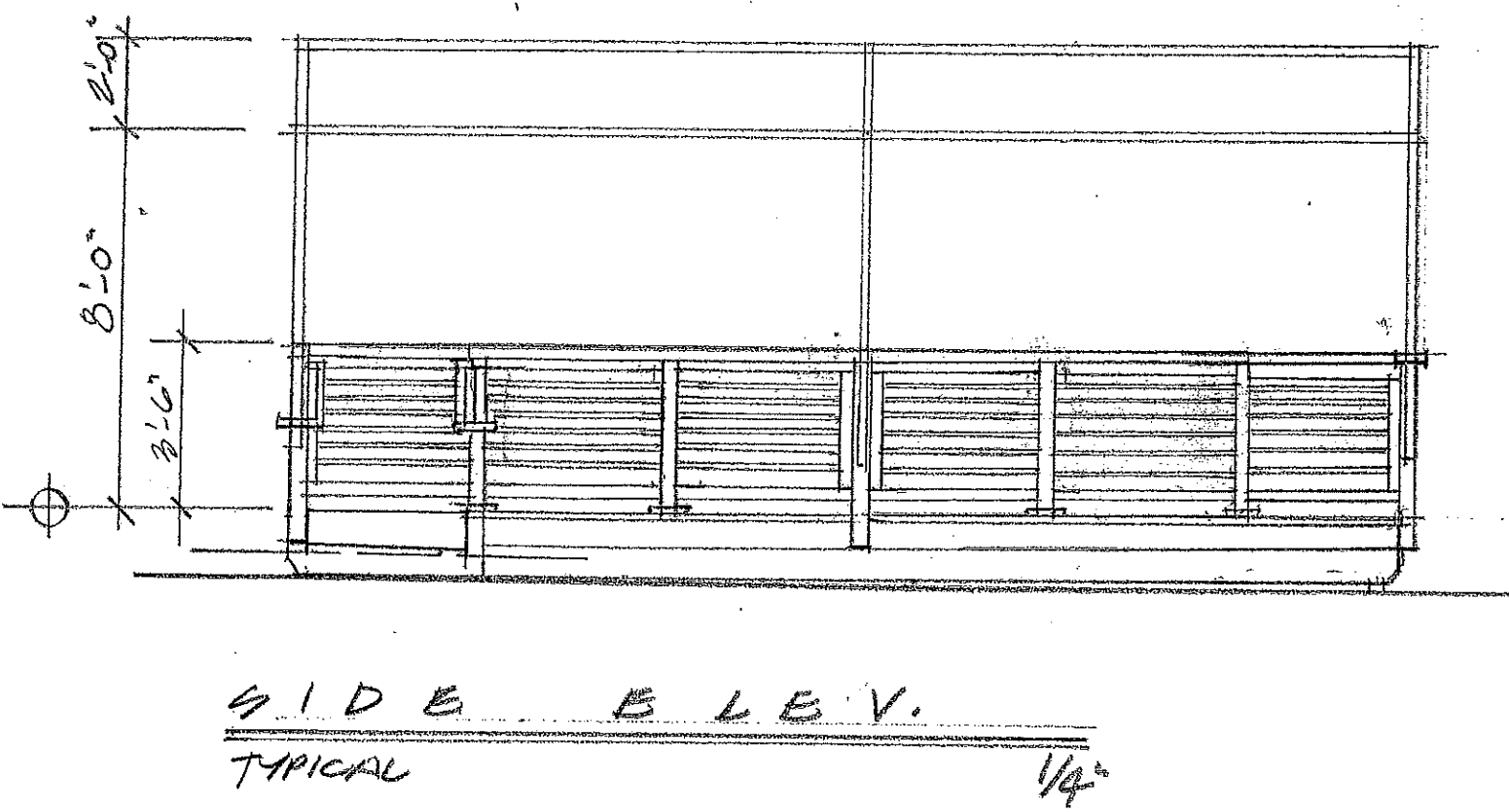
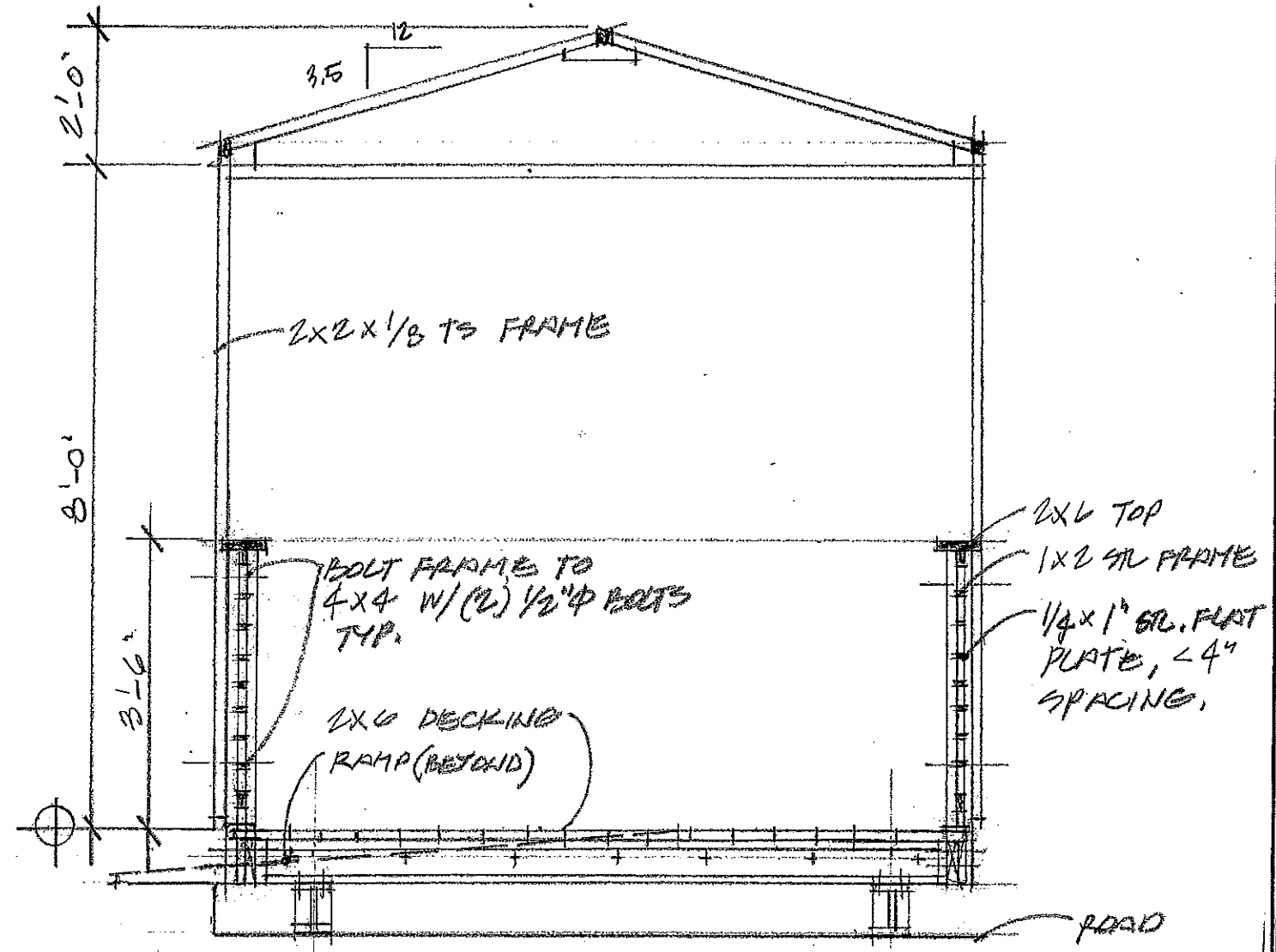
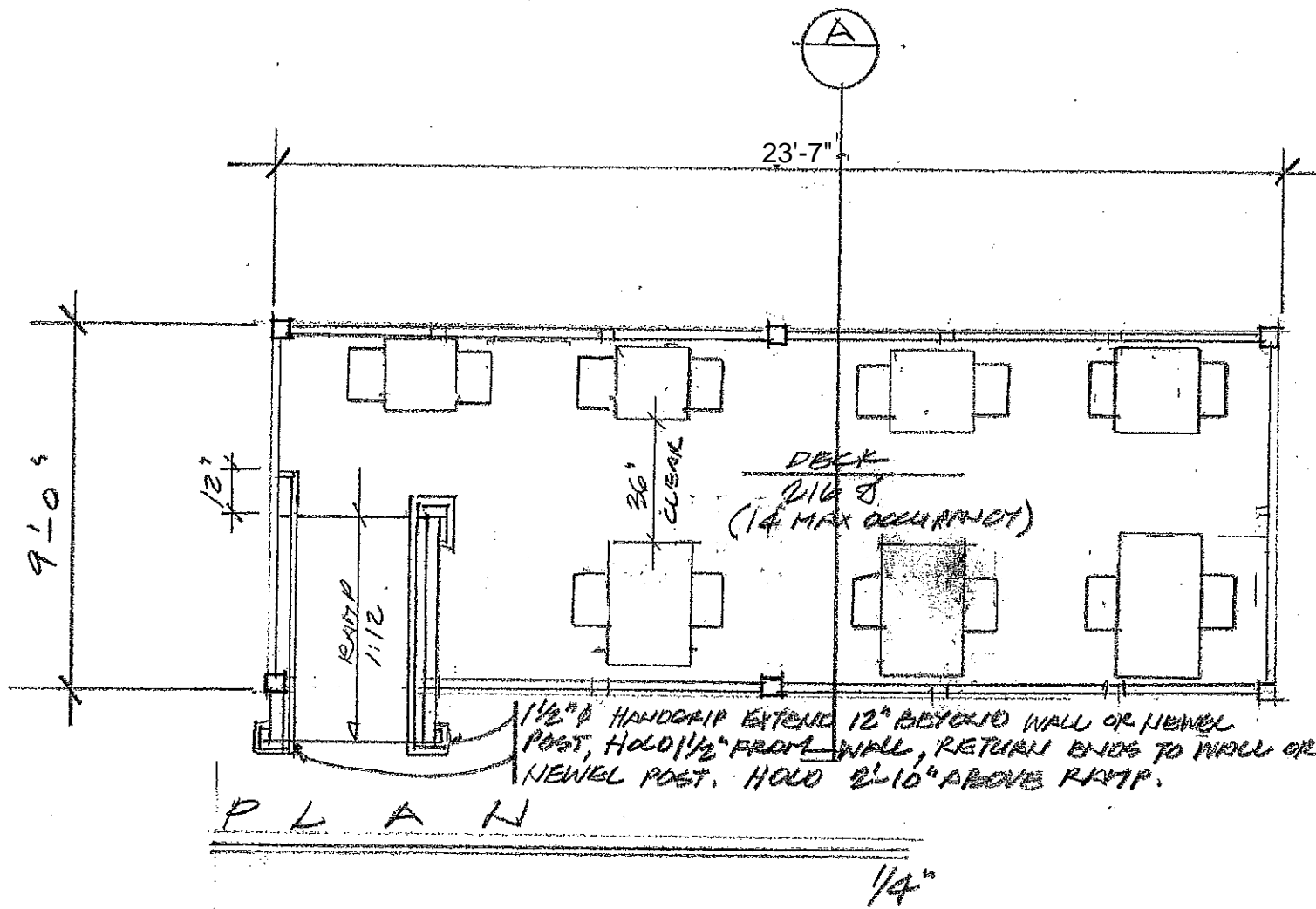

**epic** ENGINEERING

PROJECT LOCATION: SHABU DECK  
442 MAIN STREET  
PARK CITY, UT

DECK PLAN  
ELEVATIONS  
SECTION

DATE: 2.26.19

PROJECT NUMBER:

SET NUMBER:  
A.1

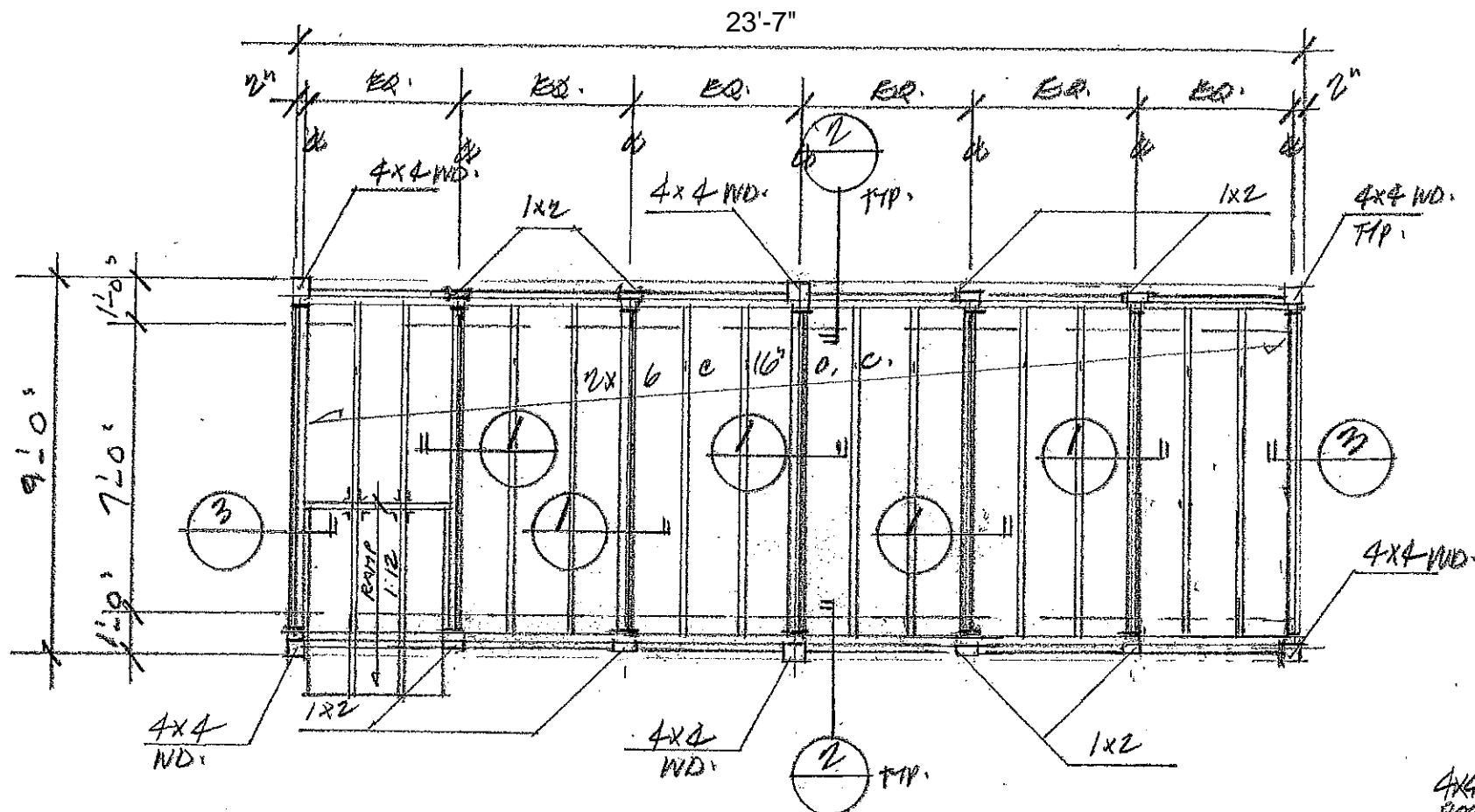

DECK FRAMING

1/4"

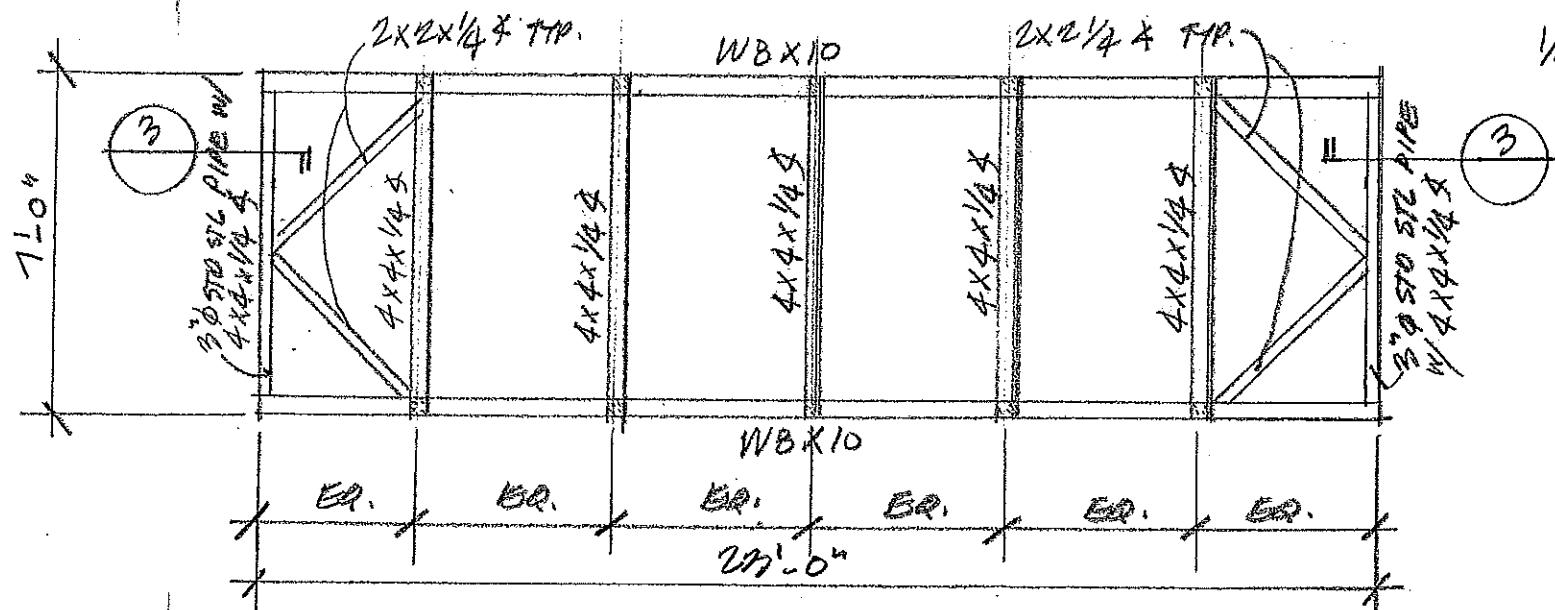

STEEL FRAME

1/4"

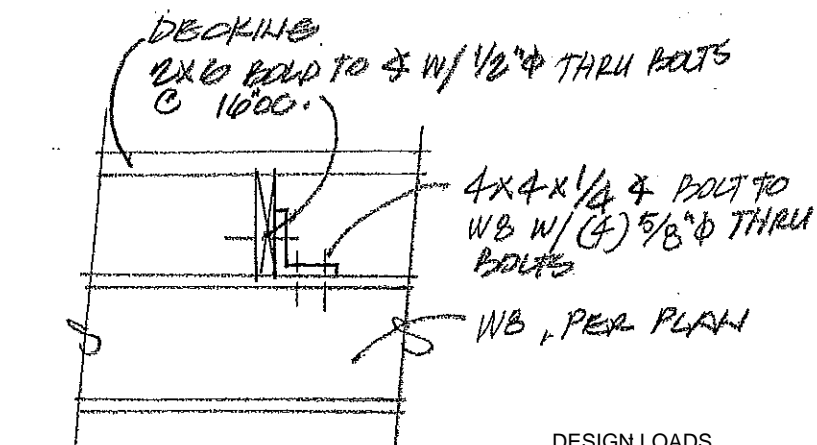

DESIGN LOADS  
 WIND: 115 MPH EXP. B  
 SNOW: N/A - DECK IS TEMPORARY FOR SUMMER MONTHS  
 DEAD LOAD: 10 PSF  
 LIVE LOAD: 100 PSF

1 DETAIL  
1" = 1/20"

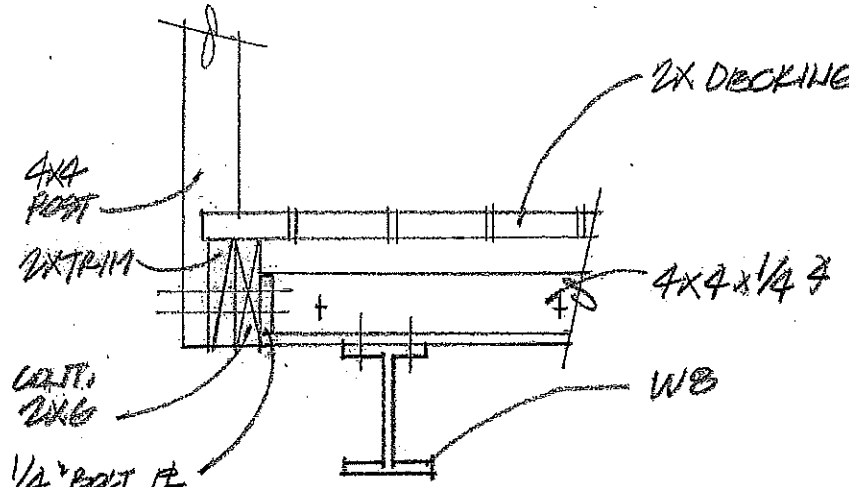

2 DETAIL  
1" = 1/20"

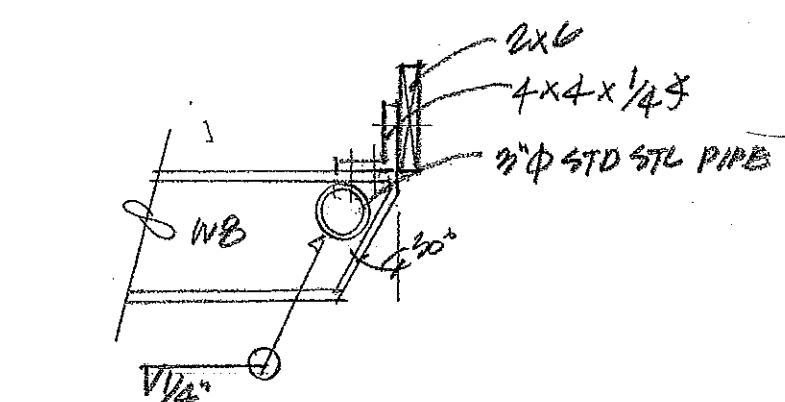

3 DETAIL  
1" = 1/20"



**epic**  
ENGINEERING

---

PROJECT DESCRIPTION: SHABU DECK  
 442 MAIN STREET  
 PARK CITY, UT

---

IDENTIFICATION: FRAMING PLANS + DETAILS

---

KEYWORDS:

---

DATE: 2.26.19

---

PROJECT NUMBER:

---

SECT NUMBER: 5.1

## Exhibit B – Street Dining Operational Restrictions

Street dining may be allowed by the Planning Department upon issuance of an Outdoor Dining Administrative Conditional Use Permit. Street dining is permitted beginning as early as April 28, and shall terminate on October 30th of each year. A total of twelve (12) street dining decks may be accommodated on Main Street based on the layout of the proposed decks. The Applicant must submit an application, pay an application fee, and provide all required materials and plans. Ongoing monitoring will be provided to ensure compliance with these parameters. The Administrative Conditional Use Permit or the Lease may be revoked for failure to comply with these restrictions.

### Required Submittals:

- Dining Site Plan – This plan shall be to scale and indicate: the Applicant's building as it relates to the exact proximity of the street dining deck. The plan shall include accurate locations of proposed chairs, tables, umbrellas, planters, and any other existing public improvements (light fixtures, fire department connections, parking meters, etc.).
- Details/specifications sheets – Shall be submitted for each piece of equipment proposed with the street dining is application. This will include all tables, chairs, umbrellas, etc.

### Design Standards:

1. Size. Street dining area shall be limited to the linear frontage a building has on Main Street and shall not exceed nine feet (9') in width. The encroachment of the proposed decks into street will not exceed seven feet, nine inches (7'-9") in width from the curb, as the encroachment of the proposed decks into the sidewalk will not exceed one foot three inches (1'-3"), unless approved by City Council. With the written permission of the adjacent property owner submitted to the City, they may extend into the neighbor's street frontage. Forty-four inches (44") of clear sidewalk width shall be available at all times where the street dining deck is being constructed. Each outdoor dining deck shall not exceed forty (40') feet in length.
2. Location/Proximity/Spacing. The City reserves the right to reject an application for an outdoor dining deck:
  - If the proposed deck is too close to a previously existing deck and would eliminate needed parallel parking along Main Street thus creating a concentrated parking issue.
  - If the proposed deck is for a restaurant that does not have direct access at street level.
  - If the proposed deck is for a business with existing outdoor dining space and the expansion of such is deemed excessive.

- If the proposed deck creates too much private use of the public right-of-way that may be deemed detrimental to the health, safety, and welfare of the area.
  - The Building, Planning, and Engineering Departments will review the location, proximity, and spacing of each street dining deck as well as impacts of traffic and public safety concerns. A recommendation will be given to the City Council for final review and approval.
3. Hours of Operation. The street dining decks shall be utilized for street dining and shall serve lunch and dinner seven (7) days a week for the duration that the decks are in the Right of Way. Lunch service shall start no later than 12:00 p.m. (noon).
  4. Material. Street dining decks may be built of wood or metal platforms and shall have a solid base. The design of the base shall complement the style of the building. The railing shall be painted solid to also complement the building. While outdoor dining deck is not subject to a complete Historic District Design Review (HDDR), the guidelines are applicable to the project.
  5. Height. The maximum height of the deck shall not exceed thirty-six inches (36") measured from existing grade to the base/floor of the deck at any given point. The layout of the deck may include a step to meet the maximum height allowed.
  6. Advertising. Additional signing or advertising beyond what is allowed by the Park City Sign Code is prohibited.
  7. Furniture. All tables and chairs shall be metal, wood, or other comparable material. Plastic furniture shall not be allowed. All furniture must be approved by the Planning Department per the historic district design review.
  8. Umbrellas. Umbrellas must be free standing and are prohibited from extending beyond the dining area. Any umbrellas shall be affixed permanently to the deck as required by the International Building Code requirements (including fire standards) and shall not create any public hazard.
  9. Lighting. No additional electric lighting is permitted, including exterior building lighting.
  10. Planters. Any proposed landscaping or atmosphere pieces shall be reviewed at the time of initial application and shall not create any public hazard or unnecessary clutter. All plant material must be maintained in a manner that ensures their viability throughout the summer outdoor dining season.
  11. Use. The use of the Premises shall not conflict with any previously existing Special Events on Main Street, specifically the Arts Fest ("Kimball Art Center"). The Kimball Art Center has been leased exclusive use of Main Street August 4-6, 2023. The Premises must be vacated (i.e., removal of decks) no later than 10:00 a.m. MT on Thursday, August 3, 2023, for the duration of Arts Fest (including set-up and breakdown) unless the Kimball Art Center consents in writing to allow Tenant's use of the Premises. If the outdoor dining structure is not removed as required, the Landlord will remove the structure at the Tenant's cost. The dates of

the 2023 Kimball Arts Festival are subject to change and as such the vacating of the Premises shall occur at 10:00 a.m. the day prior to the Arts Festival.

12. Licensing. The additional square footage of the dining area must be added to the existing licensed area for the restaurant. The Tenant shall also adhere to other applicable City and State licensing ordinances, including the Department of Alcoholic Beverage Services. It is the responsibility of the Tenant to ensure that all licenses are properly obtained and adhered to.
13. Duration. Street dining is permitted beginning April 28 and shall terminate on October 30<sup>th</sup>.
14. Health & Safety. The Use shall not violate the Summit County Health Code, Summit County Health Orders, State of Utah Health Orders, the Fire Code, or International Building Code.
15. Music. The use of outdoor speakers and music is prohibited.
16. Maintenance. The dining area shall be clean and maintained in a neat and orderly fashion.
17. Storage. All equipment and other associated materials must be removed and stored on private property during prohibited times (off season). No material associated with the outdoor dining decks may be stored outdoors on-site during the off-season.
18. Removal. Decks must be completely removed from the Right-of-Way prior to the end of business day October 30. If the outdoor dining structure is not removed as required, the City will remove the structure at cost to compensate for the employees and equipment needed to complete the task.
19. Drainage. Design of the deck and its skirting shall not interfere with the existing street drainage. Deck plans shall be reviewed by the City for drainage and may be modified so as to not interfere with the existing drainage patterns of the street. Decks that have drains directly under them or downhill will be required to install screening to ensure waste does not enter the system.
20. Utilities. Access to utilities shall not be hindered by the structures. No outdoor dining decks will be approved if located in an area that blocks access to fire hydrants, etc. No new utility lines shall be installed as a result of the proposed outdoor dining.
21. Insurance Requirement. The tenant shall carry a policy of liability insurance in an amount of at least \$2 million per combined single limit per occurrence and \$3 million per aggregate for personal injury, bodily injury and property damage.

Park City Municipal Corporation shall be named as additional insured by endorsement of each policy.

22. Main Street Improvements. Due to the possible conflicts with scheduled Main Street improvements, the City may postpone approving leases until the construction schedule is finalized to be able to determine appropriate dates.

If at any time the street dining deck needs to be removed, the City will give each affected street dining business owner a minimum of 72 hours to have their decks removed. The City will not be responsible for any associated costs involving deck removal/placement or potential lost revenue.

23. Aesthetics. Due to the Park City environment and storage of the decks over the years, the decks shall be maintained in a safe and high-quality manner. Prior to final installation and occupancy of each deck, the Tenant shall make sure that the structural members can adequately meet their original design and each deck shall look aesthetically pleasing.

24. Violations. The decks shall be in compliance with all County and State Health Orders in addition to Municipal Code § 11-19-3(H) regarding Prohibition Against Issuance of Municipal Permits. From the time that any Notice of Violation is given, the City may withhold permits for any alteration, repair or construction, which pertains to any existing or new structures or signs on the property or any permits pertaining to the use and development of the real property or the structure where a violation is located. The City may withhold permits until a Notice of Compliance has been issued by the enforcement official. The City may not withhold permits that are necessary to obtain a Notice of Compliance or that are necessary to correct serious health and safety violations.

