

Park City Municipal Corporation

Call to Artists: EmPOWERment Public Art Utility Box Project



Park City Municipal Corporation (“PCMC”) is looking for artist(s)/teams (“Artist(s)/Teams”) to beautify utility boxes for the EmPOWERment Public Art Utility Box Project. Project goals include creating vibrancy on public utility infrastructure around Park City and engaging the community through visual art in ways that align with the natural environment, arts and culture, community, and history, and are reflective of Park City.

Contact:

Jenny Diersen, Special Events Manager
City Staff Liaison to the Park City Public Art Advisory Board (PAAB)

jenny.diersen@parkcity.org

Park City Municipal Corporation

445 Marsac Avenue

Park City, UT 84060

jenny.diersen@parkcity.org

PROJECT OVERVIEW:

This is Phase 2 of the original EmPOWERment project that commenced in 2018 with nine artworks on utility boxes around town. PCMC seeks proposals from Artist(s)/Teams to submit two-dimensional artwork that coincides with the EmPOWERment theme. The EmPOWERment theme should focus on the natural environment, arts and culture, community, and history and be reflective of Park City.

Original artwork will be reproduced through a printing services company and installed onto utility boxes throughout Park City. Utility boxes are the property of Rocky Mountain Power. Up to 40 works by 40 Artist(s)/Teams will be selected to have their works displayed on utility boxes. Each selected artist will receive a one-time payment for the use of their artwork on utility boxes throughout Park City.

Budget: Selected artists/teams will receive a \$400.00 payment for each artwork design (total funding for Artist(s)/Teams is \$16,000). Fabrication and installation of the wraps will be managed by PCMC through a selected printing services company and the property owner, Rocky Mountain Power. Funding for this project comes from additional Capital Improvement Project funding for Public Art. There is separate funding for the service provider that will be selected for the printing services.

Location: There are various locations. Please see Exhibit “A” attached hereto and incorporated herein. Feel free to visit the locations.

Exhibit “A” - Utility Box Locations, Measurements, and Access Agreement
Exhibit “B” – Draft Purchase and Sale Agreement for Artwork, required for selected artists only

PROJECT GOALS:

- To beautify public utility infrastructure around Park City in a way that will work in any season and makes sense for the location.
- To engage the community by soliciting art from local producers and the community.
- To engage the community in City Council’s critical priorities and lenses.
- To integrate the theme of the project with the scale and physical space of the utility boxes.

ARTIST(S)/TEAM SELECTION CRITERIA:

- Clarity of proposal and thoroughness of response (completeness of package).
- Alignment with the project’s stated theme, through both proposed design and written materials.
- Alignment with the Park City Public Art Board’s stated [Mission and Vision](#) as well as the EmPOWERment theme of the natural environment, arts and culture, community and history, and be reflective of Park City.

- Quality and artistic excellence of proposed designs, including consideration of the three-dimensional form of the utility box in their design – all sides of the utility box should be considered including the top.
- Additional sustainable or “green” practices and qualities of the artist’s process or artwork.

The selected Artist(s)/Teams will be required to adhere to the following:

- Artwork that is selected will be publically displayed outdoors. It is preferred that submissions are colorful or have high contrast, or that they are designed in a way that creates high visibility.
- Please consult utility box dimensions and photos when considering your design; art does NOT need to be submitted to scale (see Exhibit “A”). The selection committee reserves the right to determine which selected works will decorate utility boxes.
- Artists that are selected will agree that an independent service provider will be hired by PCMC to install printed reproductions of the artwork on utility boxes. The service provider may alter or remove sections of the artists’ original design to ensure that required signage for utility boxes are not moved, removed, blocked, or covered, and that any ventilation is not altered, covered, blocked, or removed.
- Artists must follow the EmPOWERment theme. Artwork that does not follow the theme will not be considered.
- Selected artists will be required to sign a Purchase and Sale Agreement for Artwork (See Exhibit “B”).
- Preference will be given to local Summit County and Park City residents including youth and adults of all ages as well as local organizations.
- Submissions may not include any logos, commercial, or promotional materials.

ARTIST(S)/TEAM SELECTION PROCESS:

The selection committee includes Public Art Advisory Board members and representatives from Rocky Mountain Power. Other members of the committee may include the Executive Director of the Park City Summit County Art Council, the City Council Liaison, and the City Staff Liaison to the Public Art Advisory Board or their designee. City staff from various departments such as Engineering, Building, Water, Planning, and Sustainability may also be included.

Finalists may be invited to interview with the selection committee. The Board will recommend up to 40 final art selections for the project. Applications will be evaluated on the factors listed in Project Goals and Artist(s)/Teams Selection Criteria. The selection committee’s recommendations and final selection of Artist(s)/Teams pursuant to this Call for Artists are conditioned upon and subject to approval by the City Council.

Park City Municipal Corporation reserves the right to reject any and all proposals for any reason, cancel or modify the terms of this Call for Artists; and/or the project at any time and for any reason preceding contract award and reserves the right to accept or reject any or all proposals submitted pursuant to this Call for Artists. Park City does not guarantee if, or for how long, the artwork will be

displayed on the utility boxes. Park City will provide respondents with written notice of any cancellation and/or modification. Furthermore, the City shall have the right to waive any informality or technicality in proposals received when in the best interest of the City. Subject to federal, state, and local law, Park City Municipal's policy is to make reasonable attempts to support Park City businesses by purchasing goods and services through local vendors and service providers. All submittals shall be public records in accordance with government records regulations ("GRAMA") unless otherwise designated by the applicant pursuant to UCA § 63G-2-309, as amended.

PROJECT TIMELINE:

Complete Submissions due by Wednesday, June 7, 2023, at 5:00 p.m. MST.

Artists Selected by Monday, June 12, 2023, at 5:00 p.m.

Anticipated date for City Council approval is Thursday, July 6, 2023.

Contract execution for selected artists Week of July 10; 8:00 a.m. – 5:00 p.m.

Executive Office, 3rd Floor, 445 Marsac Avenue, Park City, UT 84060. If selected, we will work with you to schedule contract execution in advance.

Artwork Installation by Monday, October 30, 2023. **(Not the responsibility of the artist.)**

Questions? All questions shall be submitted in writing to jenny.diersen@parkcity.org by 5:00 p.m. on Monday, May 15, 2023.

PLEASE SEE APPLICATION FORM INCLUDED AS ATTACHMENT "1" TO COMPLETE THE APPLICATION PROCESS

Exhibit 1

APPLICATION FORM

1. Applicant Information:

Name(s): _____

Date: _____

Mailing Address: _____

City: _____ State: _____

Zip code: _____ Telephone: _____

Email: _____

Website: _____

2. Proposal: In 300 words or less, describe your proposal for the project. Explain how your design relates to the theme and scope of the project as outlined in this proposal.

3. Original Art: Artist/Team should submit one application and no more than 10 images total. If the Artist/Team is submitting multiple designs, a separate application should be completed for each. All design/concept description materials should be labeled with the applicant's name and project title. Selected original art will be digitized by an independent service provider. If submitting digitally, image resolution must be 300ppi or greater, and TIFF or EPS format.

4. Bio: Information and brief resume(s) on the Artist/Team.

5. Release, Waiver and Terms: By submitting an application, Artist/Team agrees to the following terms and conditions: If artwork is chosen, Artist/Team will receive payment of \$400 for the use of the submitted artwork. If artwork is not chosen, Artist/Team (1) will not receive any compensation and (2) is solely responsible for making arrangements to retrieve the original artwork no later than the week of July 10, 2023; after that date, the artwork becomes the property of the City and may be destroyed. The Artist/Team warrant and represent that they are the sole legal owner of all right, title and interest in all artwork, and if chosen, have the full right and authority to enter the Purchase and Sale Agreement for Artwork and grant the rights set forth therein.

The Artist/Team waives and releases the City and its officers, agents, and employees of, and from, any and all losses, damages, liability, or claims for damage to or destruction of the artwork while the artwork is in the City's custody. The Artist/Team understands and agrees that the City and its officers, agents, and employees are not responsible for reimbursement or replacement of lost, stolen, or damaged items

Proposals lacking the above-required information will not be considered.

APPLICATION DEADLINE AND SUBMISSION:

Application materials must be received at Park City Municipal Corporation offices by **5:00 p.m. MST on Wednesday, June 7, 2023.**

MAIL OR DROP OFF
APPLICATIONS TO:

Park City Municipal Corporation
Attention: Jenny Diersen, Public Art Board
445 Marsac Avenue – drop off
P.O. Box 1480 – mail
Park City, UT 84060

OR, SUBMIT
ELECTRONICALLY TO:

Jenny Diersen, City Staff Liaison to the Park City
Public Art Advisory Board
Park City Municipal Corporation
jenny.diersen@parkcity.org
Subject line must be: Utility Box Art Application

Electronic submissions cannot exceed eight megabytes to the email address. If files are larger than the maximum size allowed, they may be submitted through a private Dropbox™ account directly to jenny.diersen@parkcity.org. It is the sole responsibility of the applicant to ensure the success of the electronic submission is completed prior to the deadline as stated above. Electronic proposals with additional support documents or materials will not be accepted. The electronic submissions must be received at jenny.diersen@parkcity.org by **Wednesday, June 7, 2023, at 5:00 p.m. MST.**

Limit the response to five pages of written material including any visual material such as sketches, photographs, etc. Please be concise. Please do not place proposals in binders or binding products - you may staple or paperclip. Submit all proposals in one envelope or package.

Exhibit A – Utility Box Locations & Measurements

Utility Box Locations & Measurements

Attached is a list of Utility Boxes for the project. 40 project locations have been identified, locations may be changed or eliminated in the final selection process. Please consult the map that is also attached to this exhibit.

Location

1. Quinn's Junction fields
2. Round Valley Way (Peace House)
3. Round Valley Way (Clinic)
4. Round Valley Way (Hospital)
5. HWY 248 (Ingress)
6. Hwy 248 (School District Building)
7. Hwy 248 (School District Building #2)
8. Arts District
9. Prospector
10. Monitor Drive Across from Wells Fargo
11. Park Meadows (Monitor Drive)
12. Park Meadows (Little Kate)
13. Park Meadows (Holiday Ranch Loop / Creekside Water Treatment)
14. Versante / Peaks Hotel
15. Police Station
16. Police Station #2
17. Golf Course (Thaynes Canyon Drive)
18. Park City Hotel / Golf Course
19. Three Kings
20. 1700 Payday Condos
21. Three Kings #2
22. Golf Course #2
23. Park Ave & 15th Street
24. Park Ave & 9th Street
25. Park Ave & 9th Street #2
26. Poison Creek Trail – Near Ontario Mine Mural
27. Park City Mountain Resort (PCMR First Time Lot)
28. Park City Mountain Resort (Lowell/Manor)
29. Wheaton Way #1
30. Wheaton Way #2
31. Wheaton Way #3
32. Deer Valley Drive #1
33. Deer Valley Drive #2
34. Deer Valley Drive #3
35. Deer Valley Drive #4
36. Deer Valley Drive #5
37. Deer Valley Drive #6
38. Deer Valley Drive #7
39. Deer Valley Drive #8
40. Deer Valley Drive #9

Exhibit A – Utility Box Locations & Measurements

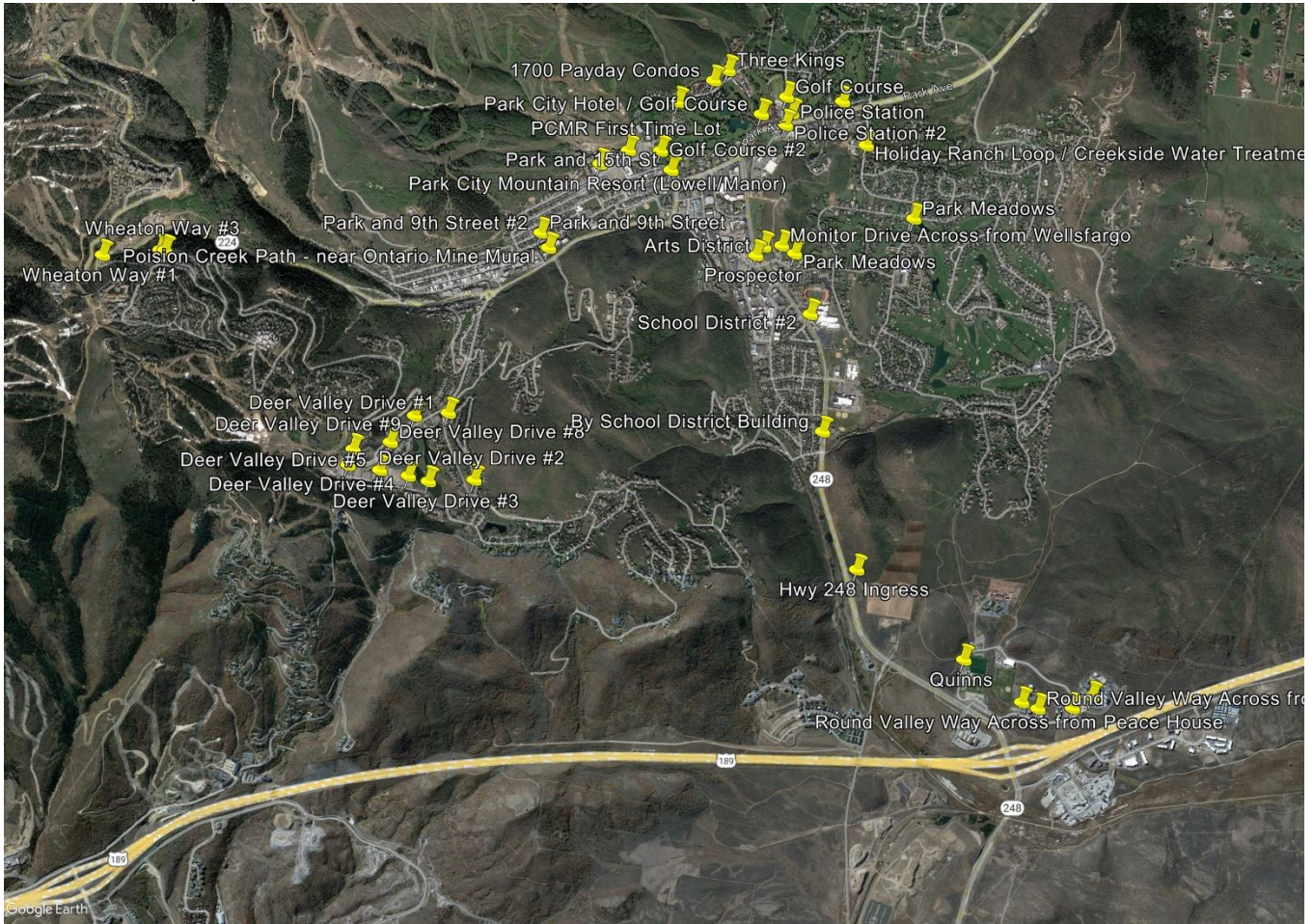

#1

Model PMH-9
14.4 kV and 25 kV Nominal

Dimensions in inches (mm)

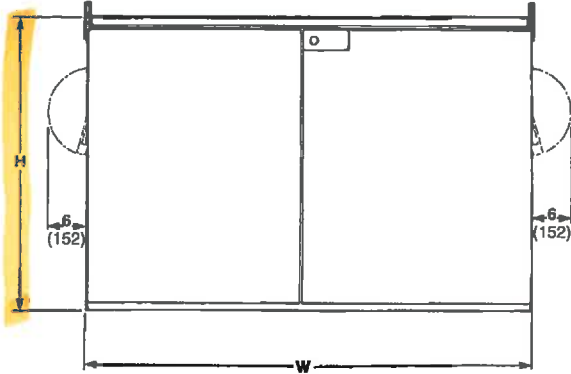

FRONT VIEW

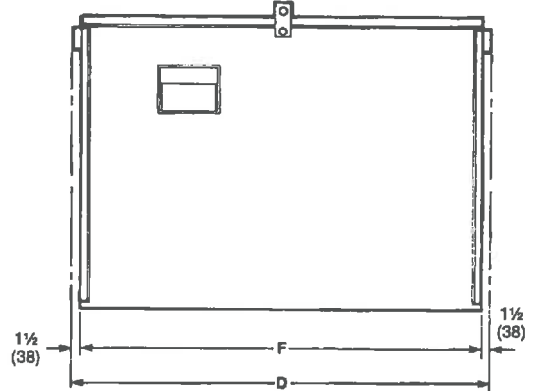

SIDE VIEW

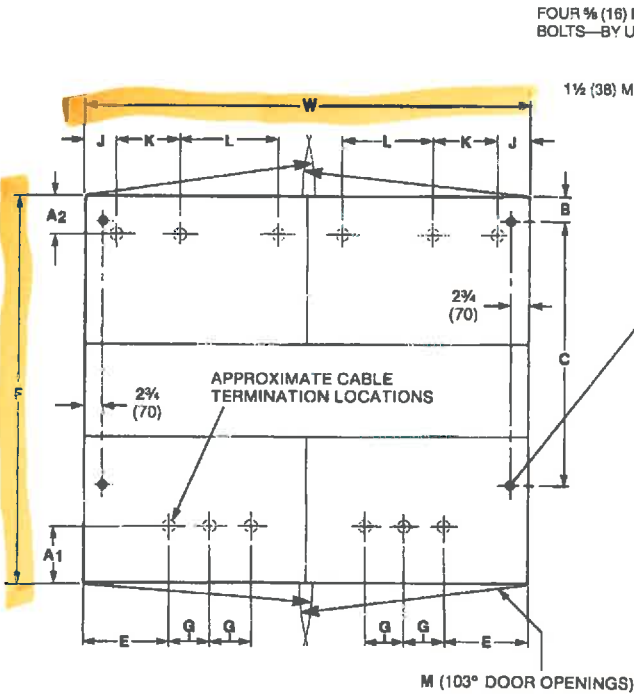

ANCHOR BOLT PLAN

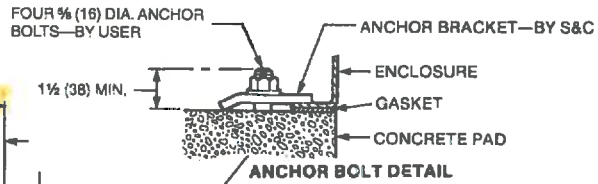

ANCHOR BOLT DETAIL

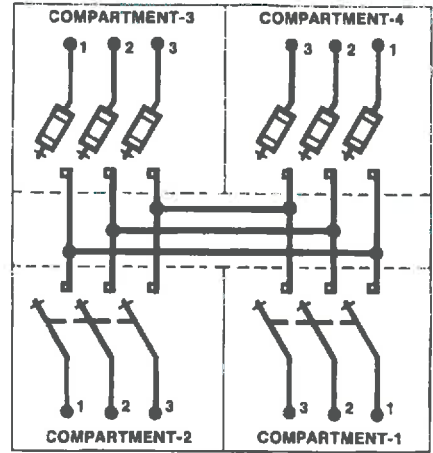

CONNECTION DIAGRAM

| kV, Nominal | A ₁ ◆ | A ₂ | B | C | D | E | F | G | H | J | K | L | M | W |
|-------------|------------------|-----------------|----------------|------------------|------------------|-----------------|------------------|----------------|--------------|----------------|-----------------|-----------------|------------------|--------------|
| 14.4 | 9 7/8 (251) | 7 (178) | 5 1/2 (130) | 40 (1016) | 63 3/4 (1619) | 12 7/8 (327) | 80 3/4 (1543) | 6 (152) | 44 (1118) | 4 3/4 (121) | 9 3/4 (248) | 14 3/4 (375) | 34 (864) | 67 (1702) |
| 25 | 14 1/8 (359) | 11 1/4 (286) | 7 1/8 (181) | 62 1/2 (1588) | 79 3/4 (2026) | 13 3/4 (349) | 76 3/4 (1949) | 7 1/2 (191) | 55 (1397) | 6 (152) | 12 1/2 (318) | 16 1/2 (419) | 41 1/2 (1054) | 82 (2083) |

◆ When Catalog Number Suffix "-M1," "-U2," or "-U3" is specified, cable-termination locations will be slightly affected. Consult your nearest S&C Sales Office for details.

#2

S&C Manual PME Pad-Mounted Gear

Model PME-11

Dimensions in inches (mm)

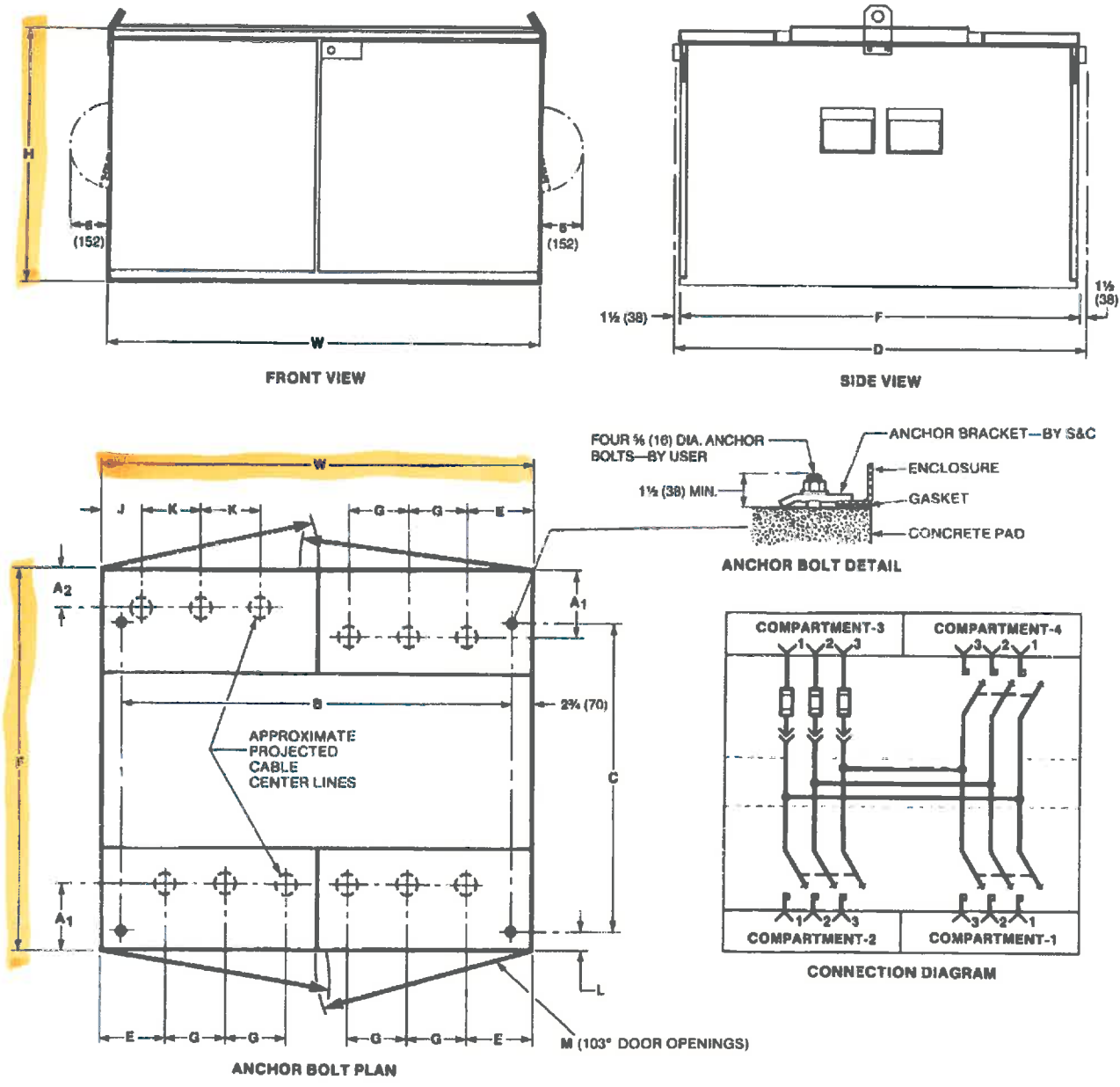

| kV, Nominal | A ₁ ◆ | A ₂ ◆ | B | C | D | E | F | G | H | J | K | L | M | W |
|-------------|------------------|------------------|---------------|---------------|---------------|--------------|---------------|-------------|----------------|-------------|--------------|--------------|---------------|--------------|
| 14.4 | 14½ (368) | 7 (178) | 69½ (1765) | 55½ (1765) | 75¾ (1924) | 12¾ (314) | 72¾ (1848) | 8¼ (210) | 45.5 (1156) | 5½ (137) | 10¼ (273) | 8½ (219) | 38 (965) | 75 (1905) |
| 25 | 18½ (470) | 8½ (206) | 78½ (1994) | 58½ (1468) | 91¼ (2318) | 12¾ (327) | 88¼ (2242) | 8¼ (210) | 51.5 (1308) | 6 (152) | 12 (305) | 14¾ (378) | 42½ (1080) | 84 (2134) |

◆ Projected cable center lines are applicable for PME models with cable installed in a cable pit. For cable installed in conduit, refer to pages 22 and 23.

Model PME-9

Dimensions in inches (mm)

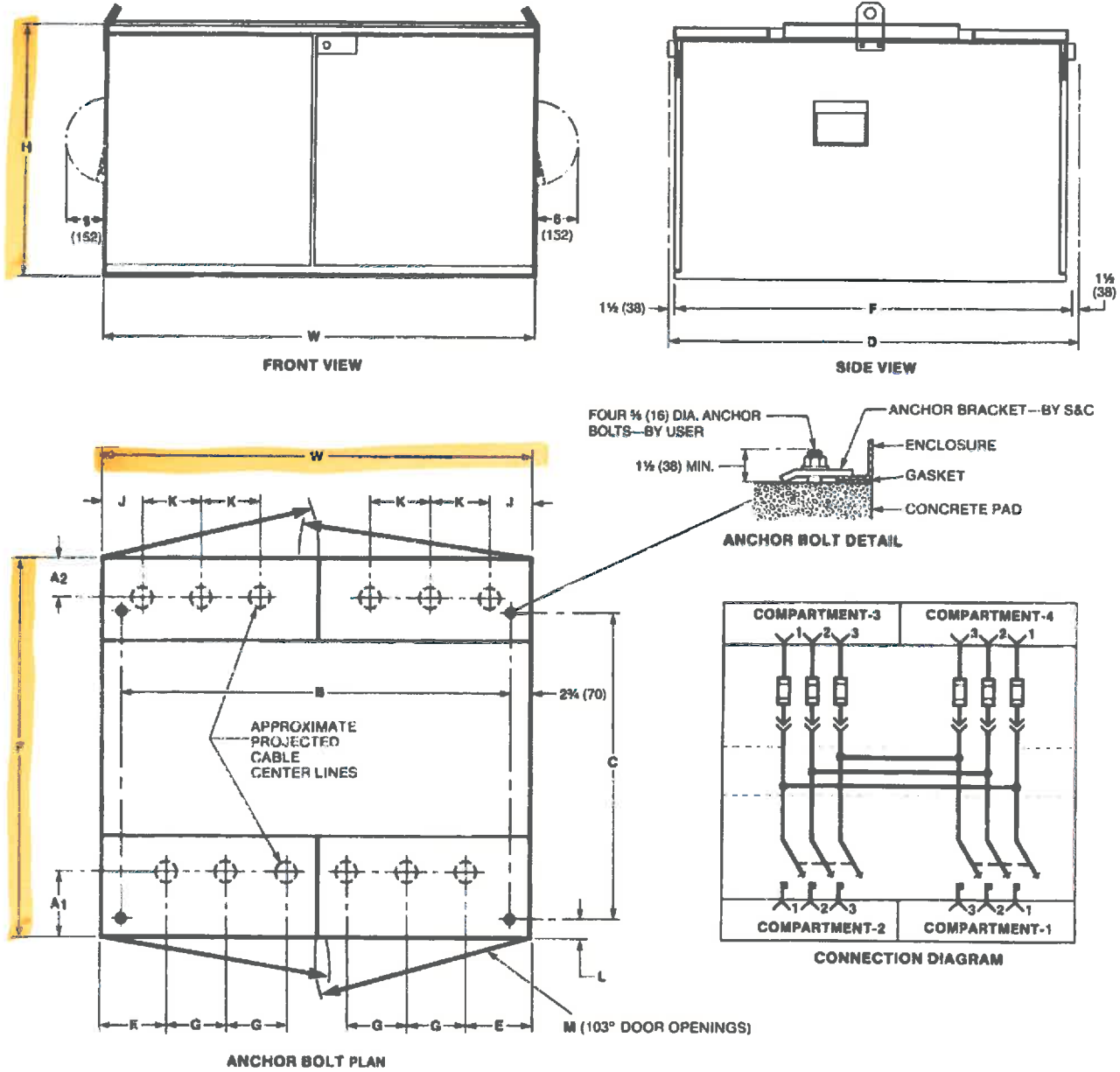

| kV, Nominal | A ₁ ◆ | A ₂ ◆ | B | C | D | E | F | G | H | J | K | L | M | W |
|-------------|------------------|------------------|------------------|------------------|------------------|-----------------|------------------|----------------|----------------|----------------|-----------------|-----------------|------------------|--------------|
| 14.4 | 14 1/2 (368) | 7 (178) | 69 1/2 (1765) | 49 1/2 (1257) | 69 3/4 (1772) | 12 3/4 (314) | 66 3/4 (1695) | 8 1/4 (210) | 45.5 (1156) | 5 3/8 (137) | 10 3/4 (273) | 8 3/8 (219) | 38 (965) | 75 (1905) |
| 25 | 18 1/2 (470) | 8 1/8 (206) | 78 1/2 (1994) | 52 (1321) | 84 3/4 (2153) | 12 7/8 (327) | 81 3/4 (2076) | 8 1/4 (210) | 51.5 (1308) | 6 (152) | 12 (305) | 14 7/8 (378) | 42 1/2 (1080) | 84 (2134) |

◆ Projected cable center lines are applicable for PME models with cable installed in a cable pit. For cable installed in conduit, refer to pages 22 and 23.

EXHIBIT “B”
DRAFT - PARK CITY MUNICIPAL CORPORATION
PURCHASE AND SALE AGREEMENT FOR ARTWORK

THIS PURCHASE AND SALE AGREEMENT FOR ARTWORK (“Agreement”) is made and entered into this _____ day of _____, 2023, by and between **PARK CITY MUNICIPAL CORPORATION**, a Utah municipal corporation, (“City”), and _____, an individual (“Artist”).

RECITALS:

WHEREAS, the Artist has created the certain unique and original work of art, more fully described in **Exhibit “1”** attached hereto and made a part hereof (“Work”), and owns full right, title, and interest therein; and

WHEREAS the City desires to have artwork on public utility boxes and Artist’s Work has been chosen to be displayed at a location and time period as determined by City.

NOW, THEREFORE, in consideration of the terms, conditions, covenants, and performance contained herein, the parties hereto agree as follows:

1. SALE OF WORK.

The Artist hereby agrees to sell the Work to the City. All rights, title and interest to the Work shall pass to the City at such time as full payment is received by the Artist. The total fee for the Work is \$400.00.

2. METHOD OF PAYMENT.

Upon receipt of the Work by the City, the Artist will be paid by check delivered via US Mail in the full amount of \$400.00.

3. REPRESENTATIONS AND WARRANTIES:

Artist represents and warrants to the City that:

- A. Intellectual Property. Neither the Work, its components or any other element of the Work infringe or violate any copyright or other intellectual property right.
- B. Title. Title to the Work including all materials and components thereof, will pass to the City upon receipt of final payment by Artist free and clear of all liens, claims, security interests or encumbrances, hereinafter referred to as “liens,” and no materials incorporated into the Work have been acquired subject to an

agreement under which an interest therein or an encumbrance thereon has been retained by the Artist.

- C. Original Creation. Artist represents and warrants that: (a) the Work is a unique and original creation of the Artist; (b) the Work is unique and an edition of one; and (c) no identical, substantially similar, or derivative Work will be created by the Artist for any purpose without the written permission of the City.

4. INDEMNIFICATION.

A. The Artist shall indemnify the City and its agents, employees, and officers, from and shall process and defend at its own expense any and all claims, demands, suits, at law or equity, actions, penalties, losses, damages, or costs, of whatsoever kind or nature, brought against the City arising out of, in connection with, or incident to the execution of this Agreement and/or the Artist's negligent performance or failure to perform any aspect of this Agreement; provided, however, that if such claims are caused by or result from the concurrent negligence of the City, its agents, employees, and officers, this indemnity provision shall be valid and enforceable only to the extent of the negligence of the Artist; and provided further, that nothing herein shall require the Artist to hold harmless or defend the City, its agents, employees and/or officers from any claims arising from the sole negligence of the City, its agents, employees, and/or officers. The Artist expressly agrees that the indemnification provided herein constitutes the Artist's limited waiver of immunity as an employer under Utah Code Section 34A-2-105; provided, however, this waiver shall apply only to the extent an employee of Artist claims or recovers compensation from the City for a loss or injury that Artist would be obligated to indemnify the City for under this Agreement. This limited waiver has been mutually negotiated by the parties and is expressly made effective only for the purposes of this Agreement. The provisions of this section shall survive the expiration or termination of this Agreement.

B. No liability shall attach to the City by reason of entering into this Agreement except as expressly provided herein.

5. **TREATMENT OF ASSETS.**

- A. Ownership. Artist hereby irrevocably assigns, conveys, and otherwise transfers to City and its respective successors and assigns, all right, title and interest to the Work including all proprietary rights thereto.
- B. Display. City shall have the right to display the Work at a location and time as determined in the City's sole discretion or remove the Work from display for any reason.
- C. Publicity. Artist grants to City the right to use the Artist's name, biography and photograph or likeness in connection with the Work in any manner and in any media, provided that the use is for a non-commercial purpose.

D. Duplication of Art.

(i) Artist hereby irrevocably assigns, conveys, and otherwise transfers to City and its respective successors and assigns title to the Work and all proprietary rights thereto. Artist waives any and all claims that might arise from any application of Visual Artist's Rights Amendments to the Copyright Law of the United States, 17 U.S.C. §106A ("VARA"). The rights provided herein are in lieu of any rights the Artist may have under VARA.

(ii) In view of the intention that the Work in its final dimension shall be unique, Artist shall not make any additional exact duplication or reproductions of the final Work, nor shall Artist grant permission to others to do so except with the written permission of the City; provided however, that the Artist may use depictions of the Work in personal promotional materials such as portfolios or resumes, and techniques and design elements from the Work in creation of other artwork.

(iii) Notwithstanding the transfer to City of all right, title and interest to the Work, Artist grants to the City and its assigns an irrevocable license to make two- and/or three-dimensional reproductions of the Work or any portion thereof for commercial or noncommercial purposes, including but not limited to reproductions used in advertising, brochures, media publicity, fundraising, and catalogs or other similar publications, provided that these rights are exercised in a tasteful and professional manner. Wherever practicable, City shall make reasonable efforts to include Artist's name in any such advertisement, brochure, media publicity, catalog or other similar

publication in which the Work appears and to notify the Artist of its efforts.

- E. Independent Sale. If in the future the City wishes to sell the Work separate and apart from any real property to which the Art may be integrated or affixed, the City will use reasonable efforts to provide the Artist an opportunity to purchase the Work from the City. However, no liability shall attach to the City by virtue of this section.
- F. Notice. Artist agrees to keep the City notified in writing of changes in Artist's address, and failure to do so shall be deemed a waiver of Artist's right of first refusal above.

6. **ENTIRE AGREEMENT.**

This Agreement shall be binding upon the parties hereto, their heirs, successors, assigns, and personal representatives. This Agreement constitutes the entire understanding between the parties. Its terms can be modified only by an instrument in writing signed by both parties. A waiver of any breach of any of the provisions of this Agreement shall not be construed as a continuing waiver of other breaches of the same or other provisions hereof. This Agreement shall be governed by the laws of the State of Utah.

IN WITNESS WHEREOF the parties hereto have caused this Agreement to be executed the day and year first hereinabove written.

PARK CITY MUNICIPAL CORPORATION, a
Utah municipal corporation
445 Marsac Avenue
Post Office Box 1480
Park City, UT 84060-1480

Matt Dias, City Manager

Attest:

City Recorder's Office

Approved as to form:

City Attorney's Office

DRAFT

ARTIST

Name: _____

Address: _____

City/State/Zip: _____

Signature

[To be signed by a parent or legal guardian if the **ARTIST** is under the age of eighteen (18):]

The Undersigned parent or legal guardian acknowledges that he/she is not only signing this Agreement on his/her behalf, but that he/she is also signing on behalf of the minor and that the minor shall be bound by all the terms of this Agreement.

Parent/Guardian: _____

Address: _____

City/State/Zip: _____

Signature

DRAFT

EXHIBIT "1"
DESCRIPTION OF WORK:

DRAFT