

<p>(435) 649-9467 CONSULTING ENGINEERS LAND PLANNERS SURVEYORS 323 Main Street P.O. Box 2664 Park City, Utah 84060-2664</p>	<b>STAFF:</b> MICHAEL DEMKOWICZ CONNOR DINSMORE ZACHARY ALHAMRA	<b>DEER VALLEY DRIVE AUTOTURN EXHIBITS          TRANSIT HUB          BUS/FLEX LANE PRIORITY OPTION</b>	<b>SHEET          4</b>
	<b>DATE:</b> 12/02/2022	<b>FOR:</b> DEER VALLEY <b>JOB NO.:</b> 11-1-19 <b>FILE:</b> X:\SnowParkVillage\dwg\Snow Park Development\exhibits\Autoturn\Autoturn_OPTION BUS.dwg	

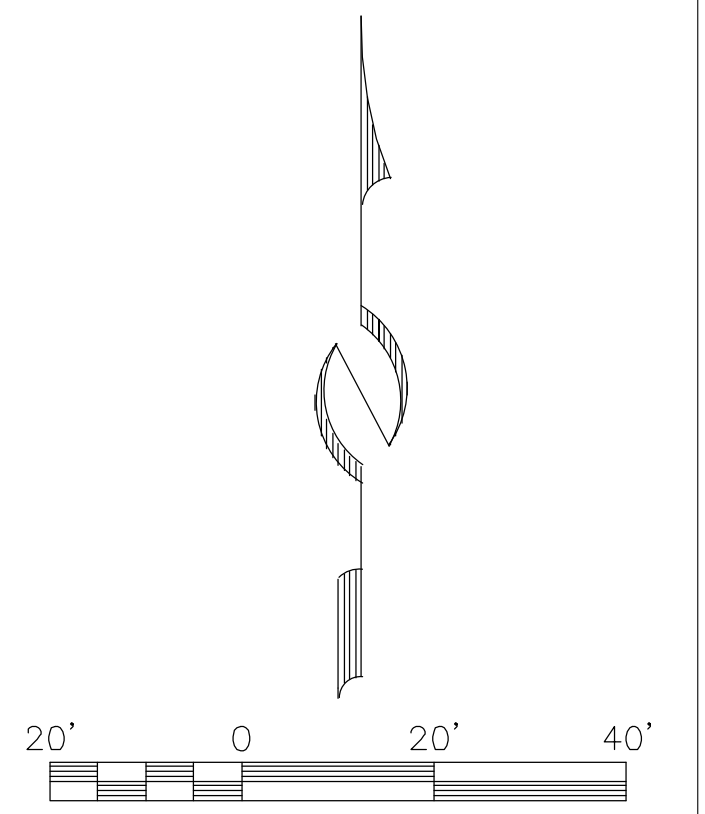

 (435) 649-9467 <small>CONSULTING ENGINEERS LAND PLANNERS SURVEYORS</small> <small>323 Main Street P.O. Box 2664 Park City, Utah 84060-2664</small>	<b>STAFF:</b> MICHAEL DEMKOWICZ CONNOR DINSMORE ZACHARY ALHAMRA	<b>DEER VALLEY DRIVE AUTOTURN EXHIBITS          TRANSIT HUB          BIKE LANE PRIORITY OPTION</b>	<b>SHEET 5</b>
	<b>DATE:</b> 12/02/2022	<b>FOR:</b> DEER VALLEY <b>JOB NO.:</b> 11-1-19 <b>FILE:</b> X:\SnowParkVillage\dwg\Snow Park Development\exhibits\Autoturn\Autoturn_OPTION BUS.dwg	

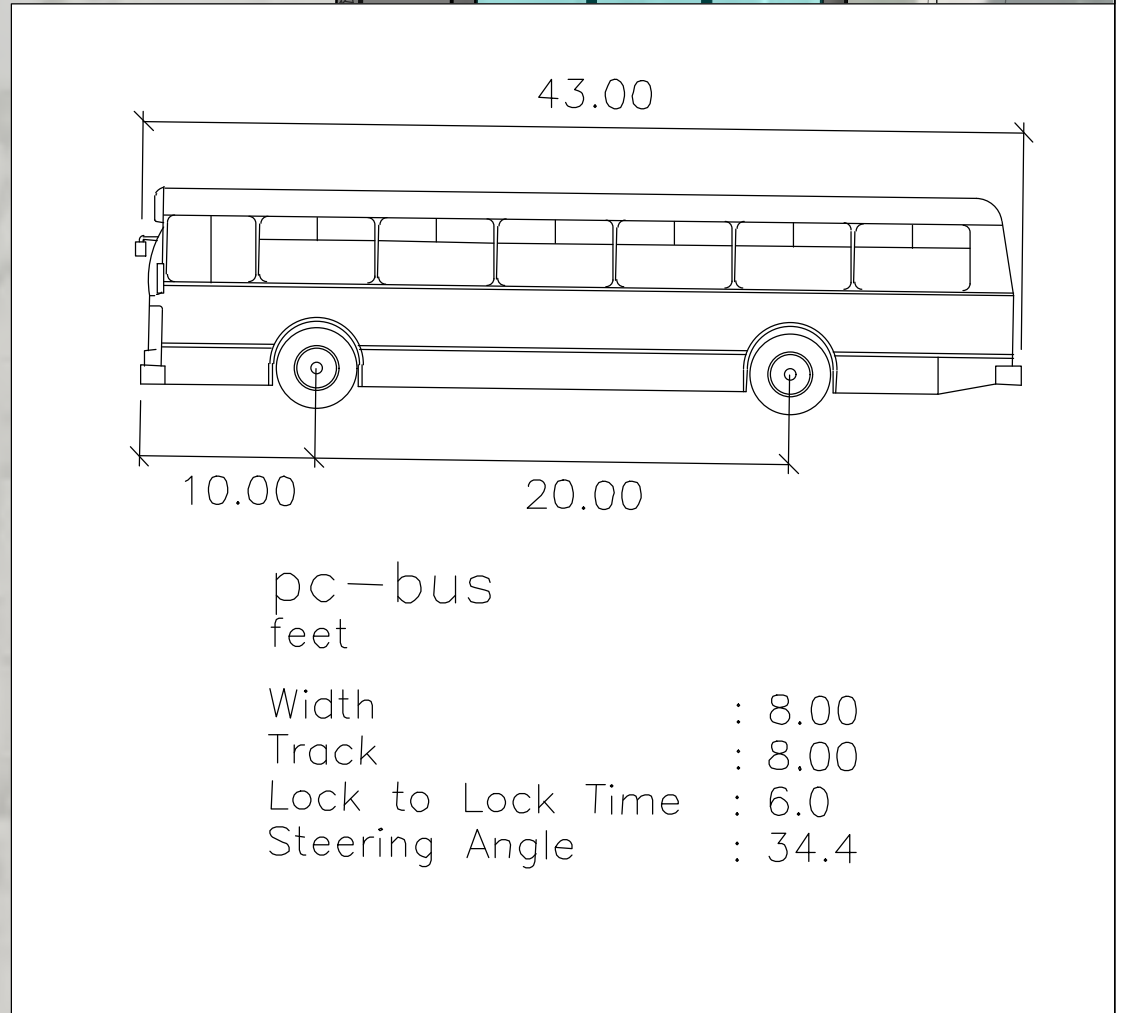
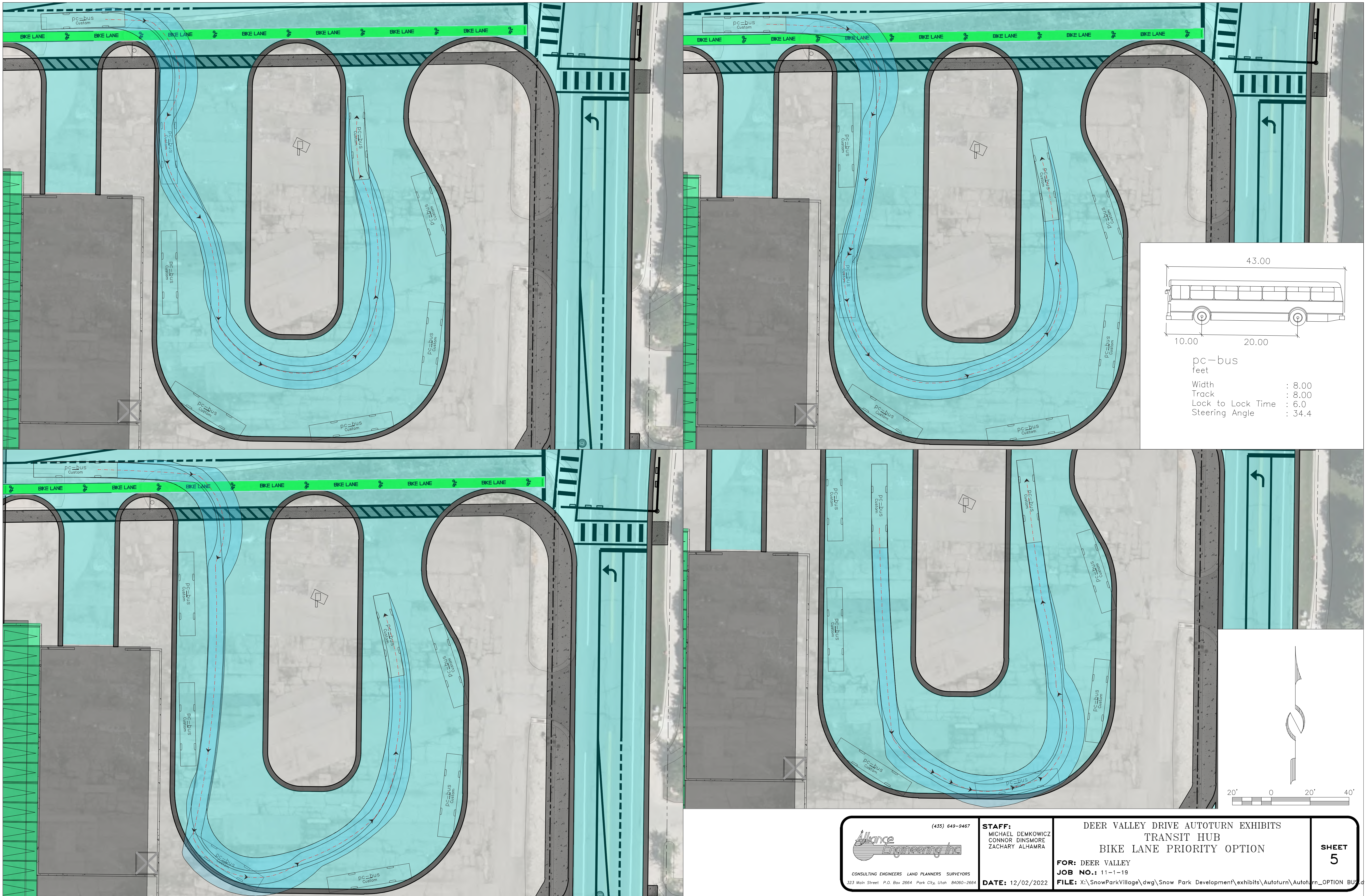
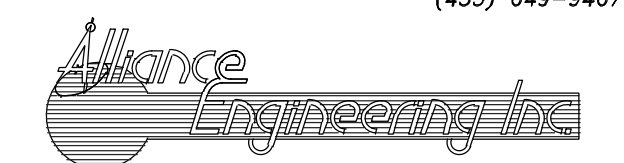
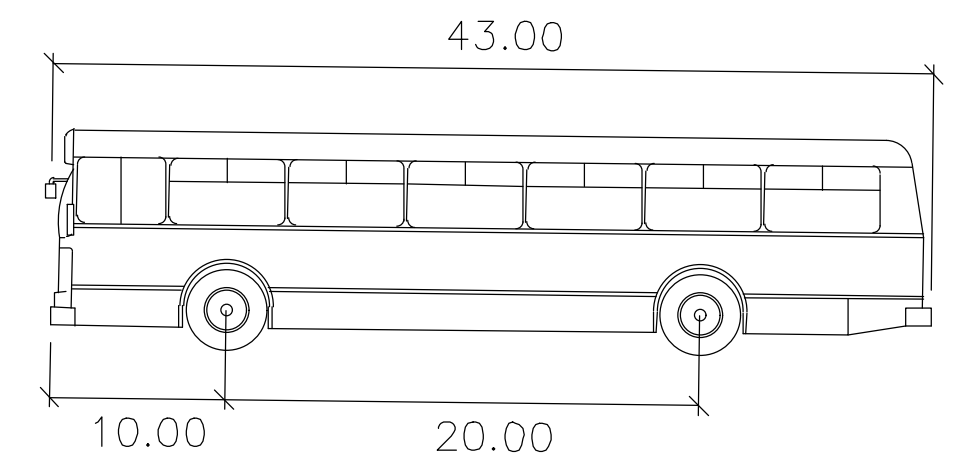
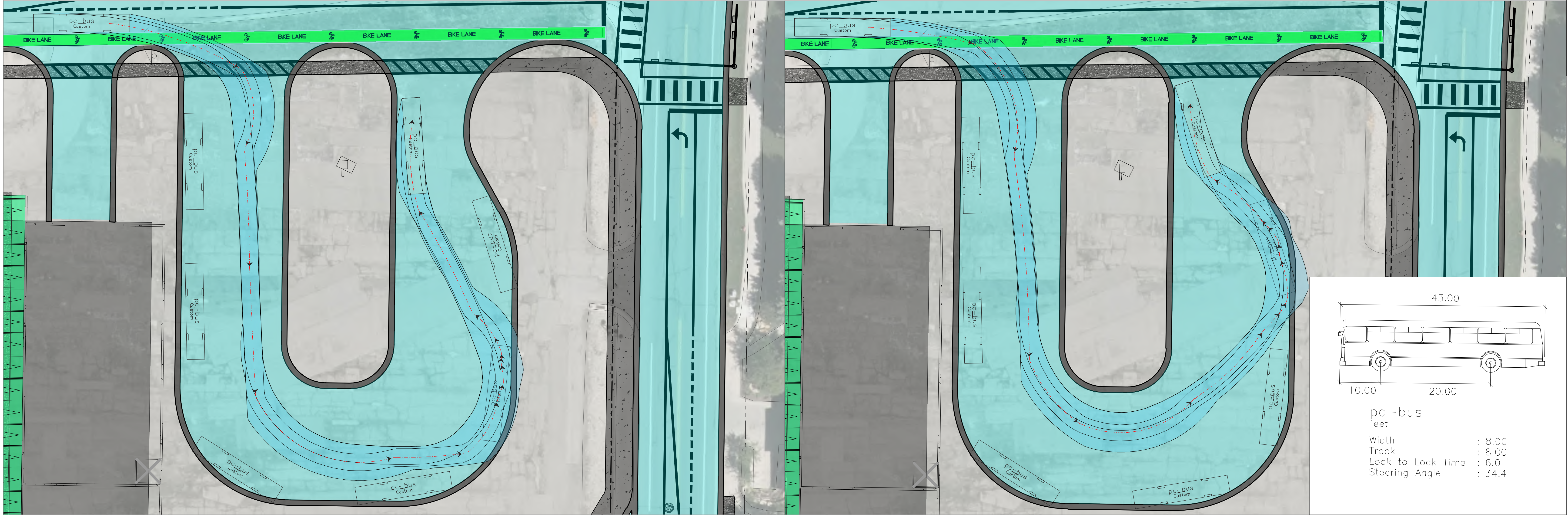

pc-bus  
feet

Width	: 8.00
Track	: 8.00
Lock to Lock Time	: 6.0
Steering Angle	: 34.4

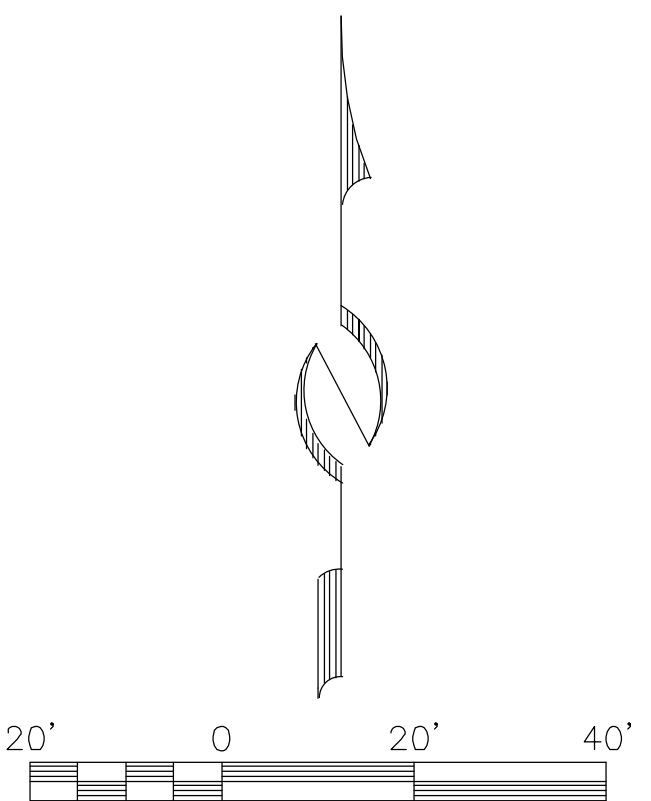

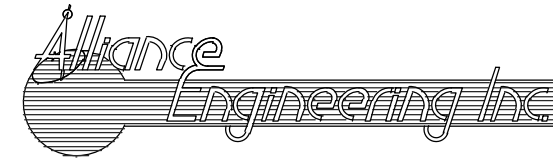
 (435) 649-9467 <small>CONSULTING ENGINEERS LAND PLANNERS SURVEYORS</small> <small>323 Main Street P.O. Box 2664 Park City, Utah 84060-2664</small>	<b>STAFF:</b> MICHAEL DEMKOWICZ CONNOR DINSMORE ZACHARY ALHAMRA	<b>DEER VALLEY DRIVE AUTOTURN EXHIBITS</b> <b>TRANSIT HUB</b> <b>BIKE LANE PRIORITY OPTION</b>	<b>SHEET</b> <b>6</b>
	<b>DATE:</b> 12/02/2022	<b>FOR:</b> DEER VALLEY <b>JOB NO.:</b> 11-1-19 <b>FILE:</b> X:\SnowParkVillage\dwg\Snow Park Development\exhibits\Autoturn\Autoturn_OPTION BUS.dwg	