

**GENERAL REQUIREMENTS –  
WATER METER, METER VAULT, AND SERVICE LINE**

REFER TO SPECIFICATIONS AND STANDARD PLANS FOR DETAILED WATER METER, METER VAULT, AND SERVICE LINE REQUIREMENTS

WATER METER & METER VAULT:

1. WATER METER AND RADIOREAD METER TRANSCEIVER UNIT (MXU) WILL BE PROVIDED BY THE CITY. ALL OTHER COMPONENTS SHALL BE PROVIDED AND INSTALLED BY THE DEVELOPER/BUILDER. PROVIDE 2 WEEKS ADVANCE NOTICE TO THE WATER DEPARTMENT FOR METER SET REQUESTS EXCEEDING FIVE METERS OR METER SIZES GREATER THAN 2 INCHES. APPROPRIATE METER APPLICATION AND PAYMENT OF FEES APPLY BEFORE THE CITY WILL SET A METER.
2. WATER METER SIZE SHALL BE APPROVED BY THE CITY ENGINEER PRIOR TO INSTALLATION OF ANY SERVICE LINE, METER VAULT, OR WATER MAIN TAP. SEE STANDARD DETAIL 594 FOR SIZING REQUIREMENTS. A 1.5" MINIMUM WATER SERVICE SIZE IS REQUIRED FROM THE MAIN LINE.
3. INSTALLATION OF A WATER METER EXCEEDING 2-INCH WILL REQUIRE CITY ENGINEER APPROVAL. THE METER AND VAULT WILL REQUIRE A FLOWRATE AND DEMAND ANALYSIS BY THE DEVELOPER / BUILDER AND A SITE SPECIFIC DESIGN.
4. INSTALLATION OF A WATER SERVICE LINE SIZE GREATER THAN 1-1/2" WILL REQUIRE CITY ENGINEER APPROVAL. THE SERVICE LINE UPGRADE REQUEST WILL REQUIRE SUBMITTAL OF A FLOWRATE AND DEMAND ANALYSIS BY THE DEVELOPER/BUILDER.
5. USE OF AN INSIDE WATER METER WILL REQUIRE CITY ENGINEER APPROVAL. INSIDE METERS SHALL BE USED ONLY FOR COMMERCIAL OR MULTI-UNIT BUILDINGS SUBJECT TO THE FOLLOWING CONDITIONS:
  - A. UNRESTRICTED ACCESS IS AVAILABLE TO WATER DEPARTMENT PERSONNEL
  - B. THE METER SHALL BE LOCATED IN A SEPARATE MECHANICAL ROOM
  - C. THE METER SHALL BE ASSOCIATED WITH FIRE PROTECTION SPRINKLER SYSTEM (FIRE STACK) PLUMBING
  - D. THE METER REQUIRES A SITE SPECIFIC DESIGN APPROVED BY THE FIRE MARSHAL, THE PARK CITY BUILDING DEPARTMENT, AND THE WATER DEPARTMENT. LAYOUT SHALL BE CONSISTENT WITH WATER STANDARD PLANS 523, 526, AND 528
  - E. A REMOTE RADIOREAD METER TRANSCEIVER UNIT (MXU) DEVICE SHALL BE INSTALLED AT A LOCATION ACCEPTABLE TO THE WATER DEPARTMENT. REFER TO NOTE 11.
6. METER VAULT LOCATION SHALL BE APPROVED BY THE CITY ENGINEER AND WATER DEPARTMENT PRIOR TO INSTALLATION OF ANY SERVICE LINE OR WATER MAIN TAP. MINIMUM REQUIREMENTS AROUND METER VAULT MUST BE MET. NO POWER, IRRIGATION, COMMUNICATION, CABLING, ECT. WITHIN METER VAULT CLEARANCE AREA.
7. LOCATE METER VAULT, WHENEVER POSSIBLE, IN LANDSCAPE AREAS. PLACEMENT WITHIN A PAVED SURFACE, DRIVEWAY OR WALKWAY, REQUIRES WRITTEN APPROVAL PRIOR TO INSTALLATION OF THE SERVICE LINE OR WATER MAIN TAP. THE METER VAULT SHALL BE PLACED AT THE PUBLIC RIGHT OF WAY LINE. IN THE ABSENCE OF A PUBLIC R-O-W LINE, THE METER VAULT SHALL BE LOCATED WITHIN A DEDICATED EASEMENT AND A MAXIMUM OF FIVE FEET BEHIND THE CURB AND GUTTER OR SIDEWALK AS APPLICABLE.
8. EXTEND THE SERVICE LINE STUB ON THE CUSTOMER SIDE TO 5 FEET BEYOND THE METER VAULT WITH METER VAULT CONSTRUCTION. INSTALL END CAP AND MARKER ON SERVICE LINE TERMINATION.
9. LOCATE METER VAULT TO PROVIDE CONVENIENT, SAFE, AND UNINHIBITED ACCESS FROM A PUBLIC ROW OR WATER EASEMENT. NO FENCES SHALL BE LOCATED BETWEEN THE ROW/EASEMENT LINE AND THE METER VAULT. NO OBSTRUCTIONS OR UTILITIES SHALL BE LOCATED WITHIN 3 FEET OF THE OUTSIDE WALL OF THE METER VAULT. NO BUSHES, SHRUBS, OR PLANTS SHALL BE WITHIN 2 FEET OF THE METER LID AND NO TREES SHALL BE PLANTED SUCH THAT THE DRIP LINE AT MATURITY WILL BE WITHIN 3 FEET OF THE METER LID.
10. SET METER VAULT SET FLUSH WITH THE FINAL LANDSCAPE OR PAVEMENT GRADE. IF THE GROUND IS NOT TO FINAL GRADE AT THE TIME OF THE METER INSTALLATION OR INSPECTION, ADJUST METER VAULT WHEN FINAL GRADE IS ESTABLISHED AND ADJUST THE METER SETTER TO MEET REQUIRED

 PARK CITY MUNICIPAL CORPORATION <b>WATER</b>	<b>DATE</b>	<b>GENERAL REQUIREMENTS METER, METER VAULT, AND SERVICE LINE</b>	<b>STD. PLAN</b>
	10/2020		<b>520.1</b>
	<b>REV.</b>		
	0		

VAULT DIMENSIONS. REFERENCE STANDARD PLANS 592 AND 593 FOR METER VAULT GRADING REQUIREMENTS.

11. IN MOST CASES THE METER TRANSCEIVER UNIT (MXU) DEVICE WILL MOUNT THROUGH THE METER VAULT LID. IF METER LOCATION DOES NOT PERMIT A CLEAR RELIABLE MXU DEVICE RADIO SIGNAL TO CITY FACILITIES, A REMOTE MXU DEVICE WILL BE REQUIRED. THE REMOTE MXU DEVICE WILL BE INSTALLED BY THE CITY, AT A LOCATION DETERMINED BY THE CITY, AT THE TIME OF THE METER INSPECTION. IN MOST CASES THE REMOTE MXU DEVICE WILL BE INSTALLED ON THE OUTSIDE OF THE BUILDING FACING A PUBLIC STREET. PROVIDE CONDUIT AND SIGNAL WIRE FROM METER VAULT TO REMOTE MXU DEVICE LOCATION, REFERENCE STANDARD PLAN 530. FOR DEVELOPMENT PROJECTS, A SIGNAL PROPAGATION STUDY AND INSTALLATION OF A NEW REPEATER STATION AT THE DEVELOPER'S EXPENSE MAY BE REQUIRED.
12. IF REPLACING METER VAULT, PROTECT EXISTING METER AND MXU DEVICE, TAG OR LEAVE IN VAULT. CONTACT PARK CITY WATER DEPARTMENT PRIOR TO REMOVING OR REPLACING METER.
13. PROTECT METER VAULT AND MXU DEVICE THROUGHOUT CONSTRUCTION.
14. A WATER METER WILL NOT BE SET BY THE CITY UNTIL THE METER VAULT AND SERVICE LINE ARE IN COMPLIANCE WITH THE MOST CURRENT VERSION OF THE ENGINEERING STANDARDS, STANDARD DRAWINGS, AND APPROVED PROJECT DRAWINGS, A METER INSPECTION HAS BEEN PERFORMED AND DEFICIENCIES CORRECTED, AND ALL APPLICABLE FEES PAID.
15. ALL BRASS AND BRONZE PIPE, FITTINGS, AND VALVES SHALL MEET LOW LEAD COMPLIANCE REQUIREMENTS IN ACCORDANCE WITH ANSI/ASTM 371.
16. PROVIDE COMPRESSION STYLE FITTINGS AND VALVES. FLARED STYLE CONNECTIONS ARE NOT ALLOWED.

SERVICE LINE:

1. ROUTE SERVICE LINES AT A 90 DEGREE ANGLE TO THE FRONT PROPERTY/R-O-W/EASEMENT LINE FROM THE WATER MAIN. AVOID ROUTING SERVICE LINES UNDER DRIVEWAYS.
2. MAINTAIN 5 FEET OF HORIZONTAL SEPARATION BETWEEN TAP LOCATION AND UTILITY CROSSINGS.
3. DUCTILE IRON WATER MAIN: MAINTAIN 2 FEET SEPARATION BETWEEN SERVICE LINE TAP AND ALL MAIN LINE FITTINGS, VALVES, PIPE JOINTS, AND OTHER SERVICE TAPS.
4. PVC WATER MAIN: MAINTAIN 3 FEET SEPARATION BETWEEN SERVICE LINE TAP AND ALL MAIN LINE FITTINGS, VALVES, PIPE JOINTS, AND OTHER SERVICE TAPS.
5. WATER SERVICE LINE SHALL BE CONTINUOUS. NO BENDS, FITTINGS, COUPLERS, OR CONNECTIONS, ARE PERMITTED BETWEEN WATER MAIN CORPORATION STOP AND THE METER VAULT CURB VALVE.
6. PROVIDE COMPRESSION STYLE VALVES FITTINGS. FLARED STYLE CONNECTIONS ARE NOT ALLOWED.
7. METER VAULTS AND SERVICE LINES MUST BE INSPECTED BY THE CITY PRIOR TO BACKFILLING, UNLESS SPECIFIC PRIOR APPROVAL IS PROVIDED BY THE CITY.
8. TAPPING NEW CONSTRUCTION WATER MAIN: NOTIFY AND SECURE INSPECTION OF INSTALLATION BY CITY ENGINEER PRIOR TO TAPPING WATER MAIN. PROVIDE TAPPING "COUPON" TO CITY INSPECTOR
9. TAPPING EXISTING WATER MAIN: NOTIFY AND SECURE INSPECTION OF INSTALLATION BY WATER DEPARTMENT 48 HOURS PRIOR TO TAPPING WATER MAIN. PROVIDE TAPPING "COUPON" TO CITY INSPECTOR
10. SERVICES LINES LARGER THAN 2-INCH DIAMETER SHALL MEET WATER MAIN REQUIREMENTS.
11. ALL BRASS AND BRONZE PIPE, FITTINGS, AND VALVES SHALL MEET LOW LEAD COMPLIANCE REQUIREMENTS IN ACCORDANCE WITH ANSI/ASTM 371
12. DISINFECT ALL NEW WATER SERVICES AND APPURTENANCES IN ACCORDANCE WITH AWWA STANDARD C651-05, THE SPECIAL REQUIREMENTS OF THE *PARK CITY DESIGN STANDARDS, CONSTRUCTION SPECIFICATIONS, AND STANDARD DETAILS*, AND THE *PARK CITY WATER SYSTEM FIELD OBSERVATION GUIDELINES*. DISINFECTING, FLUSHING, AND HYDROSTATIC PLANS SHALL BE SUBMITTED TO THE CITY INSPECTOR A MINIMUM OF 5 WORKING DAYS PRIOR TO COMMENCEMENT OF ACTIVITY. CONTRACTOR SHALL NOT OPERATE EXISTING WATER VALVES.
13. TRACER WIRE IS REQUIRED FROM WATER MAIN TO METER VAULT.
14. ALL BURIED FITTINGS SHALL BE WAXED TAPED (CORPORATION STOPS, SADDLES, ECT.)
15. NO IRRIGATION CONNECTIONS ARE ALLOWED WITHIN METER VAULT

 <p>PARK CITY 1884 PARK CITY MUNICIPAL CORPORATION WATER</p>	DATE	<b>GENERAL REQUIREMENTS METER, METER VAULT, AND SERVICE LINE</b>	STD. PLAN
	10/2020		<b>520.2</b>
	REV.		
	0		

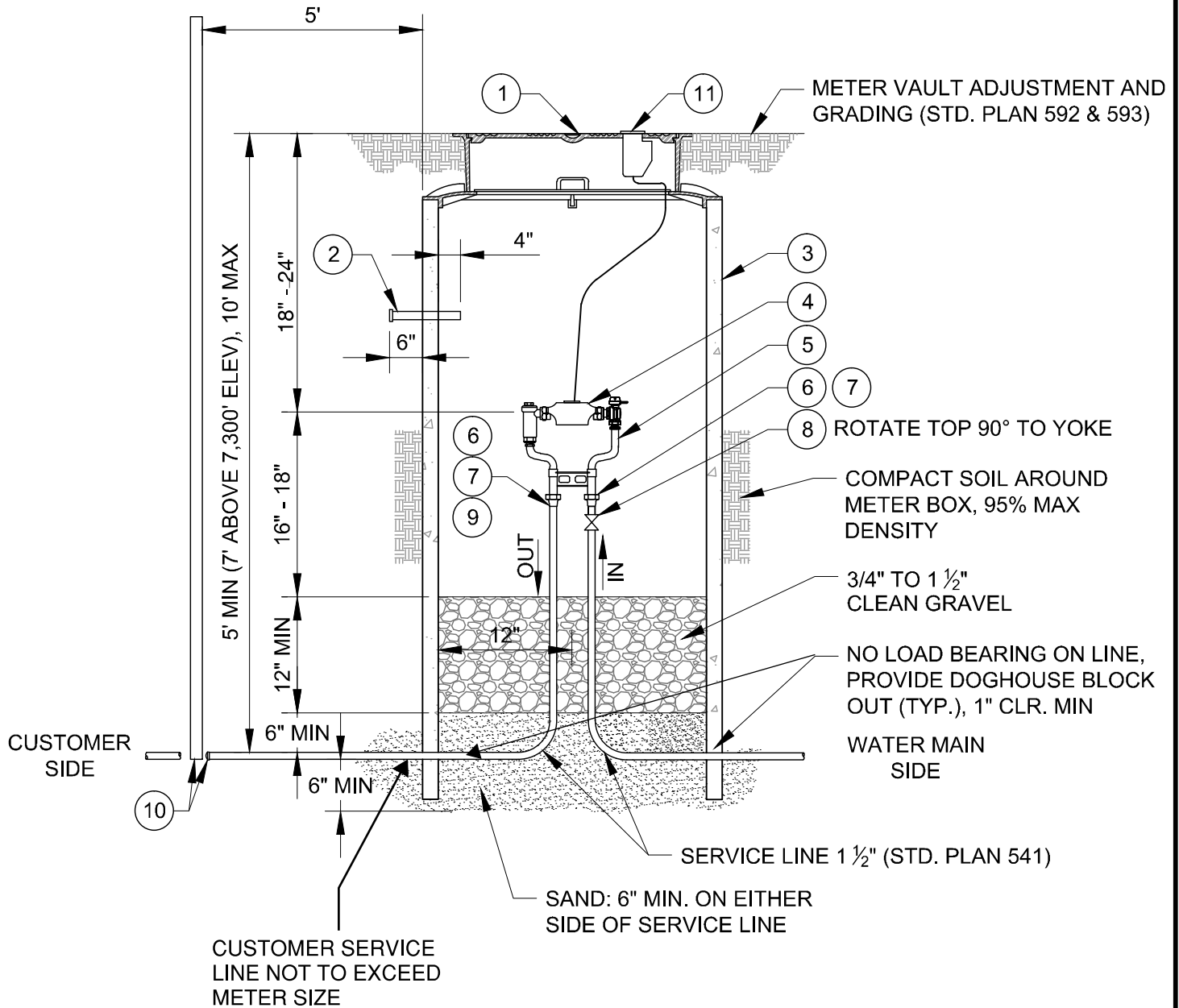

**NOTES:**

1. REFER TO STD. PLAN 520 FOR GENERAL REQUIREMENTS - METER, METER VAULT, AND SERVICE LINE.
2. REFER TO STD. PLAN 521 S FOR LEGEND ITEMS, APPROVED PARTS LIST, AND DETAIL NOTES.

 PARK CITY MUNICIPAL CORPORATION <b>WATER</b>	DATE	<b>3/4" AND 1" SINGLE METER OUTSIDE SETTING</b>	STD. PLAN
	10/2020		<b>521</b>
	REV.		
	0		

## LEGEND AND APPROVED PARTS LIST

ITEM	DESCRIPTION	ACCEPTABLE MANUFACTURER	MODELS
①	METER VAULT FRAME AND COVER (STD. PLAN 529)		
②	MXU REMOTE LOCATION CONDUIT WITH END CAPS, SCH 40 PVC (STD. PLAN 530)		
③	24" DIAMETER METER VAULT PAVED AREAS: REINF. CONCRETE PIPE LANDSCAPE AREAS: CORRUGATED DUAL-WALL HDPE PIPE	HDPE PIPE: ADS	HDPE: MEGA GREEN N-12, OR APPROVED EQUAL
④	METER, SUPPLIED AND INSTALLED BY PCMC	SENSUS	iPERL
⑤	3/4" METER YOKE	MUELLER	5/8"x3/4"x9" B2410N-6AN
		FORD	5/8"x3/4" VBHC72-9W-11-33-NL
	1" METER YOKE	MUELLER	1"x12" B2410N-6AN
		FORD	1" VBHC74-12W-11-33-NL
⑥	3/4" OR 1" METER YOKE END CONNECTION	MUELLER	MULTI X M.I.P, H-14223N
		FORD	3/4" OR 1" CLOSE BRASS NIPPLE
⑦	1-1/2" X 3/4" OR 1" BRONZE BUSHING		
⑧	1-1/2" CURB VALVE, F.I.P. X CTS (INLET)	MUELLER	B-25172N
		FORD	B41-66Q
⑨	1-1/2" CONNECTION, F.I.P. X CTS (OUTLET)	MUELLER	H-15451N
		FORD	C-14-66-G-NL
⑩	END CAP AND MARKER, CTS X F.I.P. (OUTLET)	MUELLER	H-15451N AND H-10035N
⑪	MXU AND WIRING, SUPPLIED AND INSTALLED BY PCMC		

### DETAIL NOTES

1. LOCATE METER VAULT PER APPROVED PLANS AND SET METER BOX PLUMB
2. SST INSERT STIFFENERS REQUIRED ON ALL CTS TUBING CONNECTIONS
3. WAX TAPE ALL BURIED FITTINGS (CORP STOP, SADDLE, ECT.)
4. TRACER WIRE FROM WATER MAIN TO METER VAULT

 PARK CITY MUNICIPAL CORPORATION <b>WATER</b>	<b>DATE</b>	<b>3/4" and 1" SINGLE METER OUTSIDE SETTING</b>	<b>STD. PLAN</b>
	10/2020		<b>521 S</b>
	<b>REV.</b>		
	0		

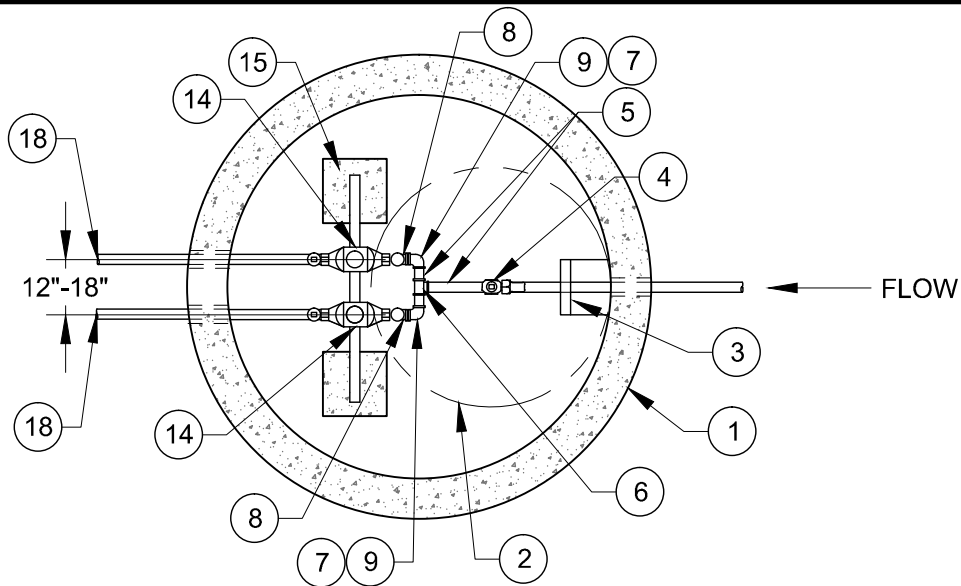

**PLAN**  
NTS

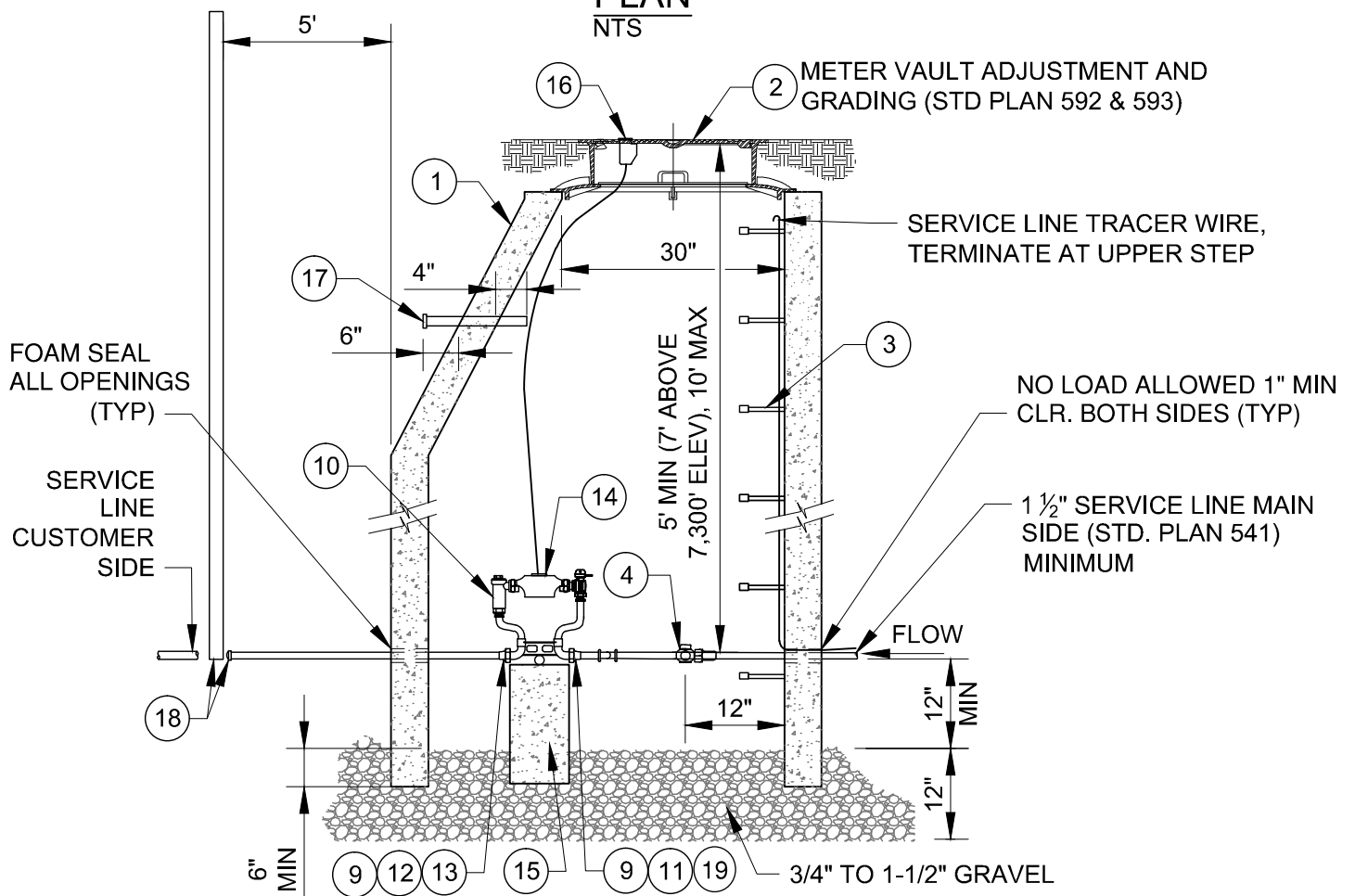

**SECTION**  
NTS

**NOTES:**

1. REFER TO STD. PLAN 520 FOR GENERAL REQUIREMENTS - METER, METER VAULT, AND SERVICE LINE.
2. REFER TO STD. PLAN 522 S FOR LEGEND ITEMS, APPROVED PARTS LIST, AND DETAIL NOTES.

 PARK CITY MUNICIPAL CORPORATION <b>WATER</b>	DATE	<b>3/4" AND 1" DUAL METERS OUTSIDE SETTING</b>	STD. PLAN
	10/2020		<b>522</b>
	REV.		
	0		

## LEGEND AND APPROVED PARTS LIST

ITEM	DESCRIPTION	ACCEPTABLE MANUFACTURER	MODELS
①	4' DIA. MANHOLE, PRECAST CONCRETE ECCENTRIC CONE AND WALL SECTIONS		ASTM C 478
②	METER VAULT FRAME AND COVER (STD PLAN 529)		
③	POLYPROPYLENE ENCASED GRADE 60 STEEL STEPS AT 13" C-C, 13-1/2" TREAD WIDTH	M.A. INDUSTRIES OR APP'D EQUAL	PS2-PFDF
④	1-1/2" CURB VALVE	MUELLER	B-25172N
		FORD	B41-666Q
⑤	1-1/2" DIA. BRASS NIPPLE X 6" LENGTH, M.I.P.		
⑥	1-1/2" DIA. BRONZE TEE, F.I.P., THREADED		
⑦	1-1/2" BRONZE 90° ELBOW, F.I.P., THREADED (2 EA)		
⑧	1-1/2" BRASS NIPPLE X 4" LENGTH, M.I.P. (2 EA)		
⑨	BRONZE BELL REDUCER REQ'D (2 EA) 3/4" YOKE: 1-1/2" X 3/4" 1" YOKE: 1-1/2" X 1" DIA.		
⑩	3/4" METER YOKE (2 EA)	MUELLER	5/8"x3/4"x9" B2404N-6AN
		FORD	5/8"x3/4" VBHC72-9W-11-33-NL
	1" METER YOKE (2 EA)	MUELLER	1"x12" B2404N-6AN
		FORD	1" VBHC74-12W-11-33-NL
⑪	3/4" OR 1" METER YOKE END CONNECTIONS (2 EA)	MUELLER	MULTI X M.I.P., H-14223N
		FORD	3/4" OR 1" CLOSE BRASS NIPPLE
⑫	1-1/2" x 3/4" OR 1" BRONZE BUSHING (OUTLET) (2 EA)		
⑬	1-1/2" CONNECTION, F.I.P. X CTS (OUTLET) (2 EA)	MUELLER	H-15451N
		FORD	C-14-66-G-NL
⑭	METER, SUPPLIED AND INSTALLED BY PCMC (2 EA)	SENSUS	iPERL
⑮	PIPE SUPPORTS, GALVANIZED PIPE SUPPORT ROD AND (2) 16"x8"x8" CMU BLOCK		
⑯	MXU AND WIRING, SUPPLIED AND INSTALLED BY PCMC		
⑰	MXU REMOTE LOCATION CONDUIT WITH END CAPS, SCH 40 PVC (STD. PLAN 531)		
⑱	END CAP AND MARKER, CTS X F.I.P. (OUTLET) (2 EA)	MUELLER	H-15451N AND H-10035N
⑲	3/4" OR 1" UNIONS (2 EA)		

### DETAIL NOTES

1. LOCATE METER VAULT PER APPROVED PLANS AND SET METER BOX PLUMB
2. SST INSERT STIFFENERS REQUIRED ON ALL CTS TUBING CONNECTION
3. USE PIPE DOPE OR TEFLON TAPE ON THREADED FITTINGS
4. WAX TAPE ALL BURIED FITTINGS. TRACER WIRE REQUIRED FROM WATER MAIN TO METER

 PARK CITY MUNICIPAL CORPORATION <b>WATER</b>	<b>DATE</b>	<h2 style="margin: 0;">3/4" and 1" DUAL METER OUTSIDE SETTING</h2>	<b>STD. PLAN</b>
	10/2020		<b>522 S</b>
	<b>REV.</b>		

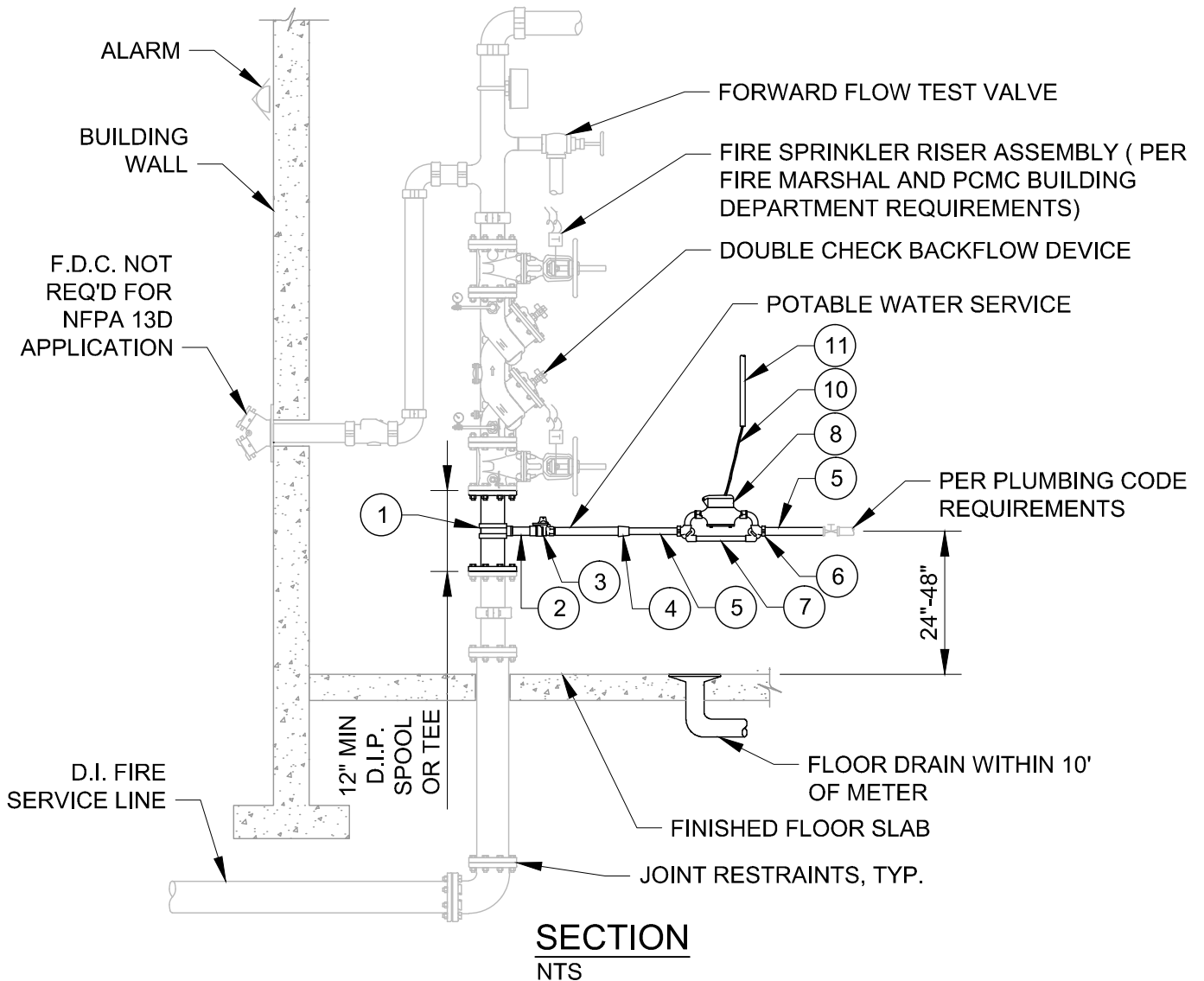
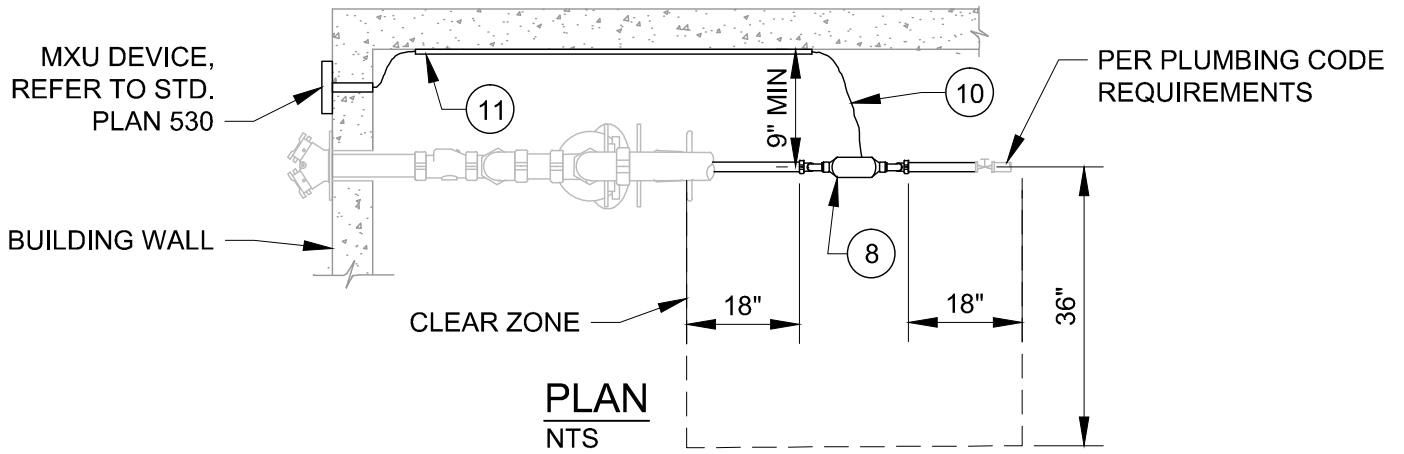

**NOTES:**

1. REFER TO STD. PLAN 520 FOR GENERAL REQUIREMENTS - METER, METER VAULT, AND SERVICE LINE.
2. REFER TO STD. PLAN 523 S FOR LEGEND ITEMS, APPROVED PARTS LIST, AND DETAIL NOTES.

 PARK CITY MUNICIPAL CORPORATION <b>WATER</b>	DATE	<b>3/4" AND 1" METER INSIDE SETTING</b>	STD. PLAN
	05/2014		<b>523</b>
	REV.		
	0		



## LEGEND AND APPROVED PARTS LIST

ITEM	DESCRIPTION	ACCEPTABLE MANUFACTURER	MODELS
①	1" BRONZE SERVICE SADDLE, DOUBLE STRAP	MUELLER	BR2B SERIES, CC THREADS
		FORD	STYLE 202B, CC THREADS
②	1" DIA. BRASS NIPPLE x 2" LENGTH, M.I.P.		
③	1" CURB VALVE, F.I.P. X F.I.P.	MUELLER	B-20283N
④	1" DIA. BRASS NIPPLE x 2" LENGTH, M.I.P. AND BRONZE BELL REDUCER, 1" X 3/4" DIA. (REQ'D FOR 3/4" METER YOKE ONLY)		
⑤	3/4" OR 1" DIA. COPPER PIPING AND FITTINGS, AS REQ'D PER SITE SPECIFIC LAYOUT		
⑥	3/4" OR 1" METER YOKE END CONNECTIONS	MUELLER	MULTI X F.I.P, H-14222N
⑦	3/4" METER YOKE (STRAIGHT LINE INLET AND OUTLET)	MUELLER	5/8"x3/4"x7" B-2418-6AN
		FORD	5/8"x3/4" LSVH11-233W-NL
	3/4" METER YOKE (VERTICAL INLET AND OUTLET)	MUELLER	5/8"x3/4"x10" B-2448-6AN
		FORD	5/8"x3/4" LSVH11-233W-NL
	1" METER YOKE (STRAIGHT LINE INLET AND OUTLET)	MUELLER	1" VBHC84-12W-11-44-NL
		FORD	1" LSVH11-444W-NL
	1" METER YOKE (VERTICAL INLET AND OUTLET)	MUELLER	1"x12" B-2448-6AN
		FORD	1" KHVBHC-4-FP-NL
⑧	METER, SUPPLIED AND INSTALLED BY PCMC	SENSUS	iPEARL
⑨	PIPE SIZE BRASS NIPPLE AND CURB VALVE, F.I.P. X F.I.P.	MUELLER	B-20283N
⑩	MXU AND WIRING, SUPPLIED AND INSTALLED BY PCMC		
⑪	EMT CONDUIT FOR MXU WIRING, AS REQUIRED		



PARK CITY MUNICIPAL CORPORATION  
**WATER**

**DATE**

10/2020

**REV.**

0

**3/4" and 1" METER  
INSIDE SETTING**

**STD. PLAN**

**523 S.1**



## DETAIL NOTES

1. USE OF AN INSIDE WATER METER REQUIRES CITY ENGINEER APPROVAL. REFERENCE WATER STANDARD PLAN 520 FOR APPLICABLE CONDITIONS.
2. FIRE SPRINKLER RISER WITH POTABLE WATER SERVICE: A SITE SPECIFIC DESIGN IS REQUIRED. THE FIRE PROTECTION SPRINKLER SYSTEM AND POTABLE WATER SYSTEM DESIGN SHALL BE APPROVED BY THE FIRE MARSHAL AND THE PARK CITY BUILDING DEPARTMENT. THE POTABLE WATER SERVICE CONNECTION AND METER ASSEMBLY DESIGN SHALL BE APPROVED BY THE PARK CITY BUILDING DEPARTMENT AND THE CITY ENGINEER. DESIGN AND CONSTRUCTION SHALL COMPLY WITH APPLICABLE BUILDING AND PLUMBING CODES.
3. BACKFLOW PREVENTION: PROVIDE A DOUBLE CHECK BACKFLOW ASSEMBLY (DCBA) OR REDUCED PRESSURE PRINCIPLE BACKFLOW ASSEMBLY (RPBA) ON THE FIRE SPRINKLER RISER ASSEMBLY. STYLE TO BE DETERMINED BY THE BUILDING AND WATER DEPARTMENT BASED ON DEGREE OF HAZARD POSED BY FIRE SPRINKLER PROTECTION SYSTEM. BEFORE A CERTIFICATE OF OCCUPANCY CAN BE ISSUED BY THE BUILDING DEPARTMENT, BACKFLOW ASSEMBLY TESTING FOR PROPER OPERATION (PER CITY REQUIREMENTS BY A CERTIFIED TESTER RECOGNIZED BY THE CITY) IS REQUIRED AND A REPORT SUBMITTED.
4. CONNECTIONS TO THE WATER SYSTEM ARE NOT PERMITTED PRIOR TO THE POTABLE WATER METER ASSEMBLY OR THE FIRE SPRINKLER RISER BACKFLOW ASSEMBLY. THIS INCLUDES OUTSIDE IRRIGATION SUPPLY.
5. CLEARANCES: PROVIDE ADEQUATE CLEARANCES FROM FIRE RISER AND AROUND WATER METER ASSEMBLY. MAINTAIN:
  - 9" MINIMUM FROM WALL TO FACE OF POTABLE WATER PIPING
  - 18" CLEAR ON EACH SIDE OF METER ASSEMBLY
  - 36" CLEAR IN FRONT OF METER ASSEMBLY
6. LOCATE METER ASSEMBLY TWO (2) TO FOUR (4) FEET ABOVE THE FLOOR. POSITION METER HORIZONTAL WITH DIAL POINTING UP.
7. PROVIDE ISOLATION (CURB) VALVES AT METER INLET AND OUTLET
8. FOR MULTIPLE METERS PROVIDE A MANIFOLD WITH A MAIN CURB VALVE PRIOR TO THE MANIFOLD AND INDIVIDUAL CURB VALVES LOCATED PRIOR TO AND AFTER METERS.
9. PROVIDE A FLOOR DRAIN IN THE FIRE RISER ROOM WITHIN 10 FEET OF THE WATER METER LOCATION.
10. PROVIDE PIPE LABELS ON THE POTABLE WATER LINE BETWEEN THE FIRE RISER AND THE WATER METER DESIGNATING PIPE AS "POTABLE WATER".
11. PROVIDE PIPE ANCHORAGE TO SUPPORT METER YOKE AND ASSEMBLY INDEPENDENT OF THE POTABLE WATER SUPPLY PIPING AND BUILDING PLUMBING. PROVIDE PIPE STANDS OR UNISTRUT WALL STANDOFFS. DO NOT SUPPORT METER ASSEMBLY FROM OTHER PIPING.
12. PROVIDE A WALL PENETRATION AND CONDUIT FOR REMOTE RADIOREAD METER TRANSEIVER UNIT (MXU) DEVICE(S). COORDINATE ROUTING AND WALL PENETRATION LOCATION WITH THE WATER DEPARTMENT. REFERENCE WATER STANDARD PLANS 520 AND 530.
13. PROVIDE 1/2" EMT CONDUIT AND SUPPORTS FOR MXU SIGNAL WIRE IF DISTANCE TO WALL PENETRATION EXCEEDS 10 FEET
14. INSPECTION: CONTACT THE CITY ENGINEER FOR INSPECTION OF THE POTABLE WATER SYSTEM METER ASSEMBLY INSTALLATION
15. REFER TO STD. PLAN 500 AND THE SPECIFICATIONS FOR FLUSHING, HYDROSTATIC TESTING, AND DISINFECTING REQUIREMENTS



PARK CITY MUNICIPAL CORPORATION  
**WATER**

**DATE**

10/2020

**REV.**

0

**3/4" and 1" METER  
INSIDE SETTING**

**STD. PLAN**

**523 S.2**

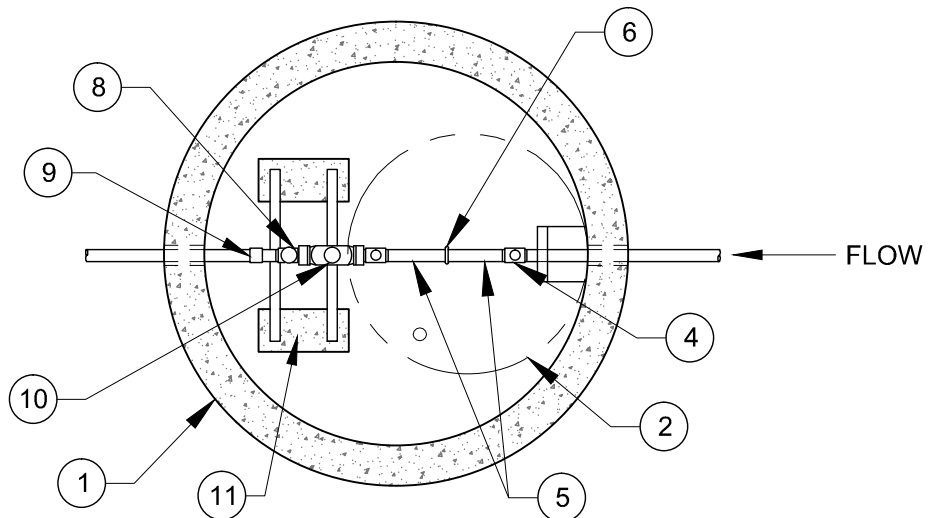

**PLAN**  
NTS

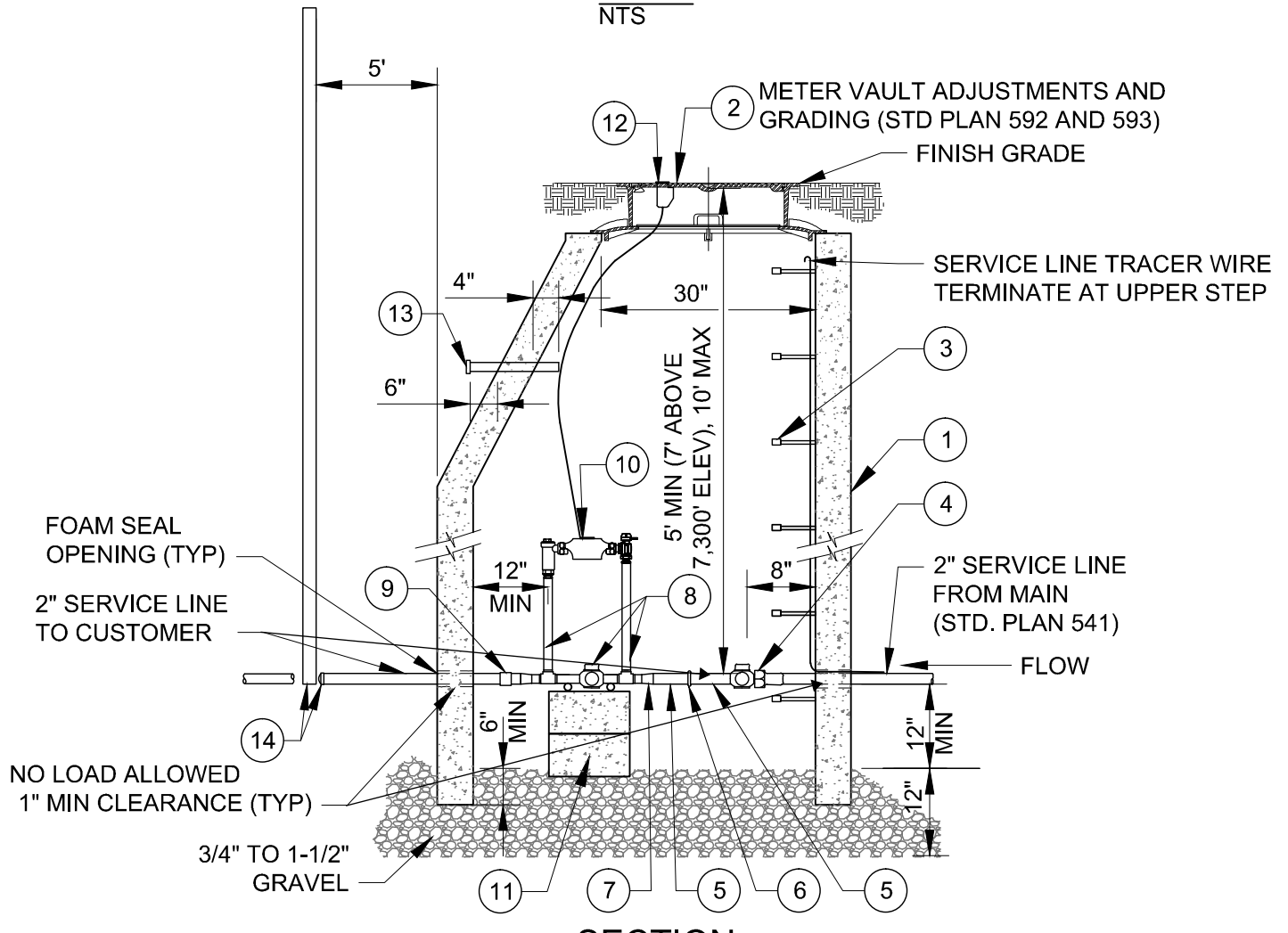

**SECTION**  
NTS

**NOTES:**

1. REFER TO STD. PLAN 520 FOR GENERAL REQUIREMENTS - METER, METER VAULT, AND SERVICE LINE.
2. REFER TO STD. PLAN 524 S FOR LEGEND ITEMS, APPROVED PARTS LIST, AND DETAIL NOTES.

 PARK CITY MUNICIPAL CORPORATION <b>WATER</b>	DATE	<b>1-1/2" AND 2" SINGLE METER OUTSIDE SETTING</b>	STD. PLAN
	05/2014		<b>524</b>
	REV.		
	0		

## LEGEND AND APPROVED PARTS LIST

ITEM	DESCRIPTION	ACCEPTABLE MANUFACTURER	MODELS
①	5' DIA. MANHOLE, PRECAST CONCRETE ECCENTRIC CONE AND WALL SECTIONS		ASTM C 478
②	METER VAULT FRAME AND COVER (STD. PLAN 529)		
③	POLYPROPYLENE ENCASED GRADE 60 STEEL STEPS AT 13" C-C, 13-1/2" TREAD WIDTH	M.A. INDUSTRIES OR APPV'D EQ.	PS2-PFDF
④	2" CURB VALVE, F.I.P. x CTS	MUELLER	B-25172N
		FORD	B11-777Q
⑤	2" DIA. BRASS NIPPLE x 4" LENGTH, M.I.P.		
⑥	2" BRONZE UNION, F.I.P., THREADED		
⑦	1-1/2" BRASS NIPPLE x 4" LENGTH, 2" x 1-1/2" BRONZE BELL REDUCER, AND 1-1/2" CLOSE BRASS NIPPLE (1-1/2" YOKE ONLY)		
⑧	1-1/2" METER YOKE COMMERCIAL SERVICE: WITH BYPASS RESIDENTIAL SERVICE: WITHOUT BYPASS IRRIGATION SERVICE: WITHOUT BYPASS	MUELLER	1-1/2"x15" B2423-2-01N (WITH BYPASS) 1-1/2"x15" B2422-2N (WITHOUT BYPASS)
		FORD	1-1/2" VBHH76-15B-11-66-NL (WITH BYPASS) 1-1/2" VBHH76-15-11-66-NL (WITHOUT BYPASS)
	2" METER YOKE COMMERCIAL SERVICE: WITH BYPASS RESIDENTIAL SERVICE: WITHOUT BYPASS IRRIGATION SERVICE: WITHOUT BYPASS	MUELLER	2"x15" B2423-2-01N (WITH BYPASS) 2"x15" B2422-2N (WITHOUT BYPASS)
		FORD	2" VBHH77-15B-11-77-NL (WITH BYPASS) 2" VBHH77-15-11-77-NL (WITHOUT BYPASS)
⑨	2" CONNECTION, F.I.P. x CTS AND 2" BRASS NIPPLE x 4" LENGTH (OUTLET); 1-1/2" YOKE ONLY: ADD 2"x1-1/2" BRONZE BELL REDUCER AND 1-1/2" CLOSE BRASS NIPPLE	MUELLER	H-15451N
		FORD	C-14-66-G-NL
⑩	METER, SUPPLIED AND INSTALLED BY PCMC	SENSUS	OMNI
⑪	PIPE SUPPORTS (4) 16"x8"x8" CMU BLOCK, (2) METER SUPPORT RODS, GALVANIZED		
⑫	MXU AND WIRING, SUPPLIED AND INSTALLED BY PCMC		
⑬	MXU REMOTE LOCATION CONDUIT WITH END CAPS, SCH 40 PVC (STD. PLAN 531)		
⑭	END CAP AND MARKER, CTS x F.I.P. (OUTLET)		H-15451N AND H-10035N

### DETAIL NOTES

1. LOCATE METER VAULT PER APPROVED PLANS AND SET METER BOX PLUMB
2. SST INSERT STIFFENERS REQUIRED ON ALL CTS TUBING CONNECTIONS

 PARK CITY MUNICIPAL CORPORATION <b>WATER</b>	<b>DATE</b>	<b>1-1/2" and 2" SINGLE METER OUTSIDE SETTING</b>	<b>STD. PLAN</b>
	10/2020		<b>524 S</b>
	<b>REV.</b>		

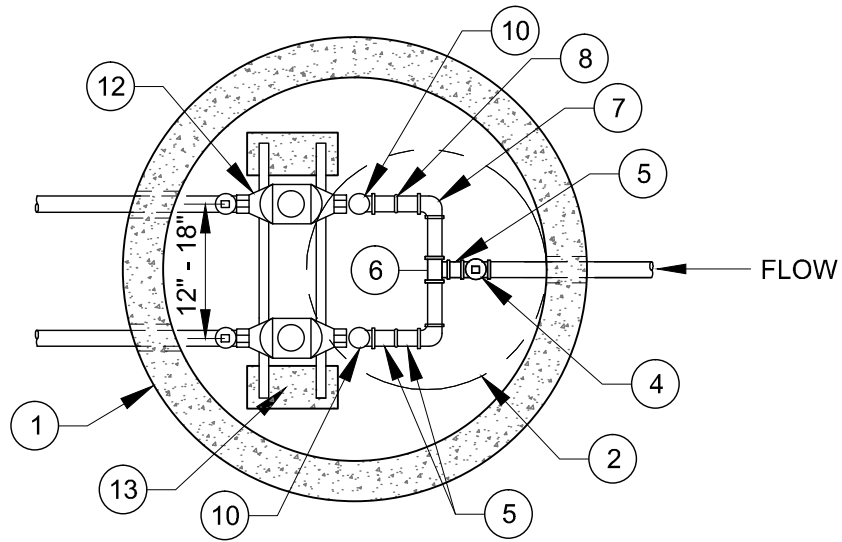

**PLAN**  
NTS

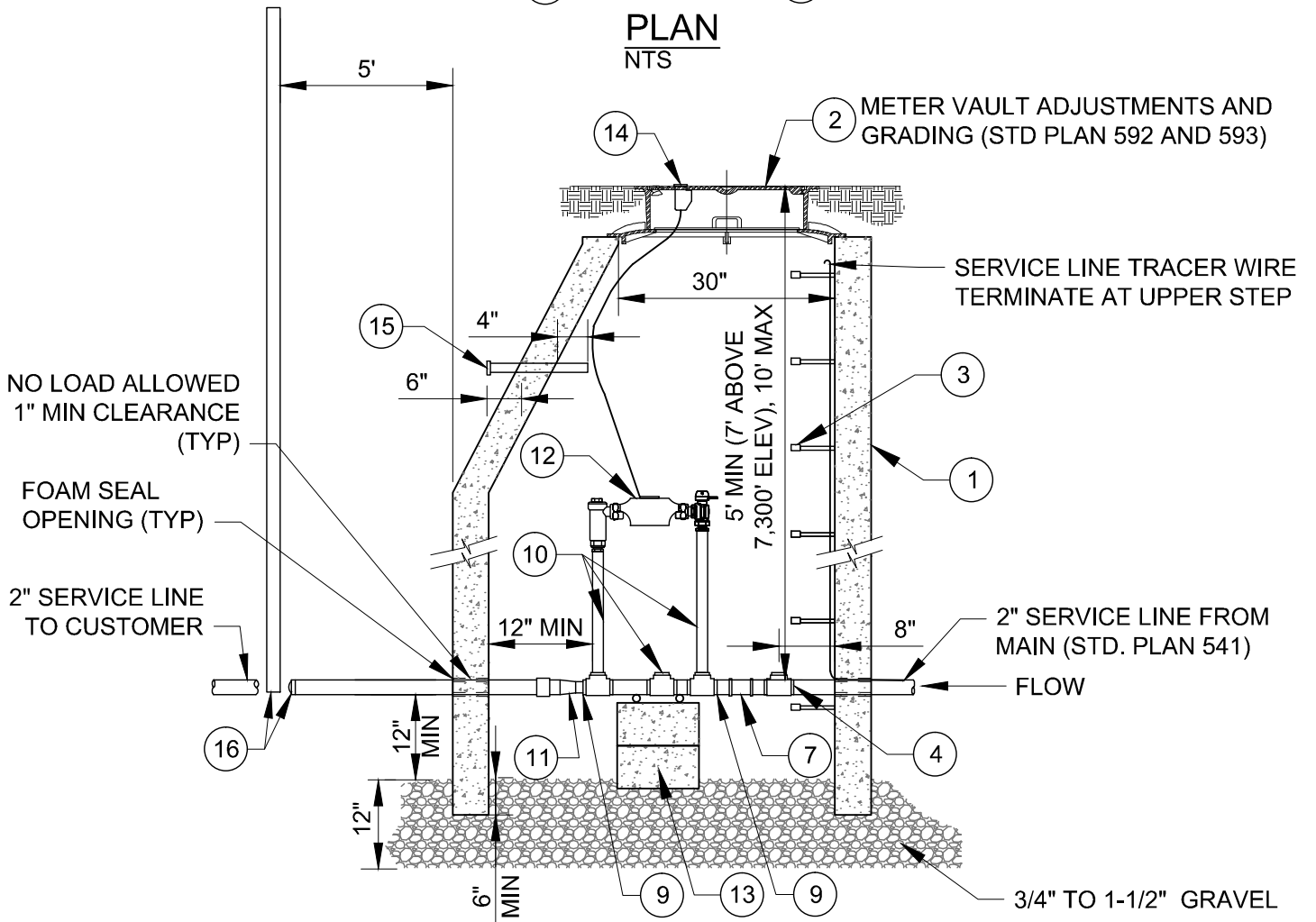

**SECTION**  
NTS

**NOTES:**

1. REFER TO STD. PLAN 520 FOR GENERAL REQUIREMENTS - METER, METER VAULT, AND SERVICE LINE.
2. REFER TO STD. PLAN 525 S FOR LEGEND ITEMS, APPROVED PARTS LIST, AND DETAIL NOTES.



PARK CITY MUNICIPAL CORPORATION  
**WATER**

DATE

05/2014

REV.

0

**1-1/2" DUAL METERS  
OUTSIDE SETTING**

STD. PLAN

**525**

## LEGEND AND APPROVED PARTS LIST

ITEM	DESCRIPTION	ACCEPTABLE MANUFACTURER	MODELS
①	5' DIA. MANHOLE, PRECAST CONCRETE ECCENTRIC CONE AND WALL SECTIONS		ASTM C 478
②	METER VAULT FRAME AND COVER (STD. PLAN 529)		
③	POLYPROPYLENE ENCASED GRADE 60 STEEL STEPS AT 13" C-C, 13-1/2" TREAD WIDTH	M.A. INDUSTRIES OR APPV'D EQ.	PS2-PFDF
④	2" CURB VALVE, F.I.P. x CTS	MUELLER	B-25172N
		FORD	B11-777Q
⑤	2" DIA. BRASS NIPPLE x 3" LENGTH, M.I.P. (5 EA)		
⑥	2" DIA. BRONZE TEE, F.I.P., THREADED		
⑦	2" BRONZE 90° ELBOW, F.I.P., THREADED (2 EA)		
⑧	2" BRONZE UNION, F.I.P., THREADED (2 EA)		
⑨	1-1/2" BRASS NIPPLE x 4" LENGTH, 2" x 1-1/2" BRONZE BELL REDUCER, AND 1-1/2" CLOSE BRASS NIPPLE (2 EA)		
⑩	1-1/2" METER YOKE (2 EA) COMMERCIAL SERVICE: WITH BYPASS RESIDENTIAL SERVICE: WITHOUT BYPASS IRRIGATION SERVICE: WITHOUT BYPASS	MUELLER	1-1/2"x15" B2423-2-01N (WITH BYPASS) 1-1/2"x15" B2422N (WITHOUT BYPASS)
		FORD	1-1/2" VBHH76-15B-11-66-NL (WITH BYPASS) 1-1/2" VBHH76-15-11-66-NL (WITHOUT BYPASS)
⑪	2" CONNECTION, F.I.P. x CTS; 2" BRASS NIPPLE x 4" LENGTH; 2"x1-1/2" BRONZE BELL REDUCER; AND 1-1/2" CLOSE BRASS NIPPLE (OUTLET) (2 EA)	MUELLER	H-15451N
		FORD	C-14-66-G-NL
⑫	METER, SUPPLIED AND INSTALLED BY PCMC (2 EA)	SENSUS	OMNI
⑬	PIPE SUPPORTS (4) 16"X8"X8" CMU BLOCK, (2) METER SUPPORT RODS, GALVANIZED		
⑭	MXU AND WIRING, SUPPLIED AND INSTALLED BY PCMC		
⑮	MXU REMOTE LOCATION CONDUIT WITH END CAPS, SCH 40 PVC (STD. PLAN 531)		
⑯	END CAP AND MARKER, CTS X F.I.P. (OUTLET) (2 EA)		H-15451N AND H-10035N

### DETAIL NOTES

1. LOCATE METER VAULT PER APPROVED PLANS AND SET METER BOX PLUMB
2. SST INSERT STIFFENERS REQUIRED ON ALL CTS TUBING CONNECTIONS

 PARK CITY MUNICIPAL CORPORATION <b>WATER</b>	<b>DATE</b>	<b>1-1/2" DUAL METERS OUTSIDE SETTING</b>	<b>STD. PLAN</b>
	10/2020		<b>525 S</b>
	<b>REV.</b>		

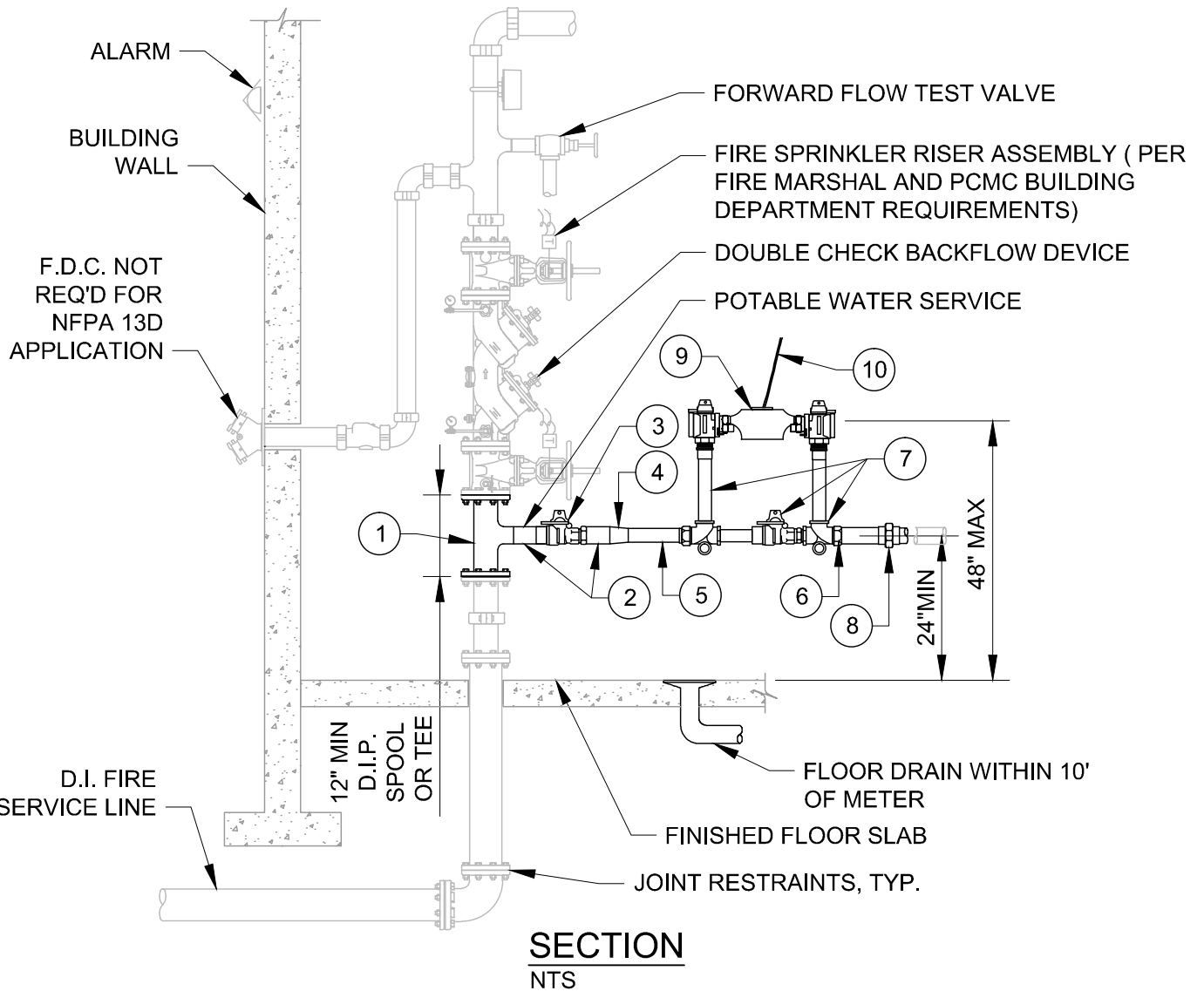
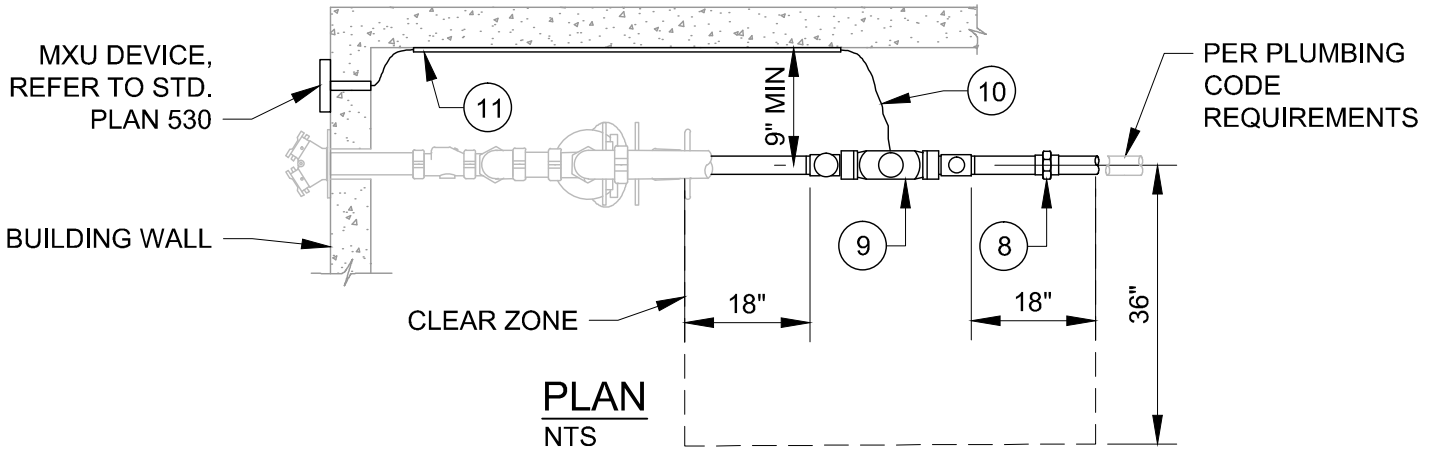

**NOTES:**

1. REFER TO STD. PLAN 520 FOR GENERAL REQUIREMENTS - METER, METER VAULT, AND SERVICE LINE.
2. REFER TO STD. PLAN 526 S FOR LEGEND ITEMS, APPROVED PARTS LIST, AND DETAIL NOTES.

 PARK CITY MUNICIPAL CORPORATION <b>WATER</b>	DATE	<b>1-1/2" AND 2" METER INSIDE SETTING</b>	STD. PLAN
	05/2014		<b>526</b>
	REV.		
	0		

## LEGEND AND APPROVED PARTS LIST

ITEM	DESCRIPTION	ACCEPTABLE MANUFACTURER	MODELS
①	DUCTILE IRON TEE OR 2" BRONZE SERVICE SADDLE, DOUBLE STRAP	MUELLER	BR2B SERIES, FIP THDS
		FORD	STYLE 202B, FIP THDS
②	2" DIA. BRASS NIPPLE x 2" LENGTH, M.I.P.		
③	2" CURB VALVE, F.I.P. X F.I.P.	MUELLER	B-20283N
		FORD	B11-777Q
④	2" DIA. BRASS NIPPLE x 2" LENGTH, M.I.P. AND BRONZE BELL REDUCER, 2" X 1-1/2" DIA. (REQ'D FOR 1-1/2" YOKE ONLY)		
⑤	1-1/2" OR 2" DIA. BRASS NIPPLES AND BRASS FITTINGS OR COPPER PIPING AND FITTINGS, AS REQ'D PER SITE SPECIFIC LAYOUT		
⑥	1-1/2" OR 2" METER YOKE END CONNECTIONS	MUELLER	MULTI X F.I.P, H-14222N
⑦	1-1/2" METER YOKE COMMERCIAL SERVICE: WITH BYPASS RESIDENTIAL SERVICE: WITHOUT BYPASS	MUELLER	1-1/2"x12" B2423-2-01N (WITH BYPASS) 1-1/2"x12" B2422-2N (WITHOUT BYPASS)
		FORD	1-1/2" VBHH76-12B-11-66-NL (WITH BYPASS) 1-1/2" VBHH76-12-11-66-NL (WITHOUT BYPASS)
	2" METER YOKE COMMERCIAL SERVICE: WITH BYPASS RESIDENTIAL SERVICE: WITHOUT BYPASS	MUELLER	2"x12" B2423-2-01N (WITH BYPASS) 2"x12" B2422-2N (WITHOUT BYPASS)
		FORD	2" VBHH77-12B-11-77-NL (WITH BYPASS) 2" VBHH77-12-11-77-NL (WITHOUT BYPASS)
⑧	PIPE SIZE BRASS NIPPLE AND BRONZE UNION, F.I.P., THREADED		
⑨	METER, SUPPLIED AND INSTALLED BY PCMC	SENSUS	OMNI
⑩	MXU AND WIRING, SUPPLIED AND INSTALLED BY PCMC		
⑪	EMT CONDUIT FOR MXU WIRING, AS REQUIRED		



PARK CITY MUNICIPAL CORPORATION  
**WATER**

**DATE**

10/2020

**REV.**

0

**1-1/2" and 2" METER  
INSIDE SETTING**

**STD. PLAN**

**526 S.1**



## DETAIL NOTES

1. USE OF AN INSIDE WATER METER REQUIRES CITY ENGINEER APPROVAL. REFERENCE WATER STANDARD PLAN 520 FOR APPLICABLE CONDITIONS.
2. FIRE SPRINKLER RISER WITH POTABLE WATER SERVICE: A SITE SPECIFIC DESIGN IS REQUIRED. THE FIRE PROTECTION SPRINKLER SYSTEM AND POTABLE WATER SYSTEM DESIGN SHALL BE APPROVED BY THE FIRE MARSHAL AND THE PARK CITY BUILDING DEPARTMENT. THE POTABLE WATER SERVICE CONNECTION AND METER ASSEMBLY DESIGN SHALL BE APPROVED BY THE PARK CITY BUILDING DEPARTMENT AND THE CITY ENGINEER. DESIGN AND CONSTRUCTION SHALL COMPLY WITH APPLICABLE BUILDING AND PLUMBING CODES.
3. BACKFLOW PREVENTION: PROVIDE A DOUBLE CHECK BACKFLOW ASSEMBLY (DCBA) OR REDUCED PRESSURE PRINCIPLE BACKFLOW ASSEMBLY (RPBA) ON THE FIRE SPRINKLER RISER ASSEMBLY. STYLE TO BE DETERMINED BY THE BUILDING AND WATER DEPARTMENT BASED ON DEGREE OF HAZARD POSED BY FIRE SPRINKLER PROTECTION SYSTEM. BEFORE A CERTIFICATE OF OCCUPANCY CAN BE ISSUED BY THE BUILDING DEPARTMENT, BACKFLOW ASSEMBLY TESTING FOR PROPER OPERATION (PER CITY REQUIREMENTS BY A CERTIFIED TESTER RECOGNIZED BY THE CITY) IS REQUIRED AND A REPORT SUBMITTED.
4. CONNECTIONS TO THE WATER SYSTEM ARE NOT PERMITTED PRIOR TO THE POTABLE WATER METER ASSEMBLY OR THE FIRE SPRINKLER RISER BACKFLOW ASSEMBLY. THIS INCLUDES OUTSIDE IRRIGATION SUPPLY.
5. CLEARANCES: PROVIDE ADEQUATE CLEARANCES FROM FIRE RISER AND AROUND WATER METER ASSEMBLY. MAINTAIN: 9" MINIMUM FROM WALL TO FACE OF POTABLE WATER PIPING  
18" CLEAR ON EACH SIDE OF METER ASSEMBLY  
36" CLEAR IN FRONT OF METER ASSEMBLY
6. LOCATE METER ASSEMBLY TWO (2) TO FOUR (4) FEET ABOVE THE FLOOR. POSITION METER HORIZONTAL WITH DIAL POINTING UP.
7. PROVIDE ISOLATION (CURB) VALVES AT METER INLET AND OUTLET
8. FOR MULTIPLE METERS PROVIDE A MANIFOLD WITH A MAIN CURB VALVE PRIOR TO THE MANIFOLD AND INDIVIDUAL CURB VALVES LOCATED PRIOR TO AND AFTER METERS.
9. PROVIDE A FLOOR DRAIN IN THE FIRE RISER ROOM WITHIN 10 FEET OF THE WATER METER LOCATION.
10. PROVIDE PIPE LABELS ON THE POTABLE WATER LINE BETWEEN THE FIRE RISER AND THE WATER METER DESIGNATING PIPE AS "POTABLE WATER".
11. PROVIDE PIPE ANCHORAGE TO SUPPORT METER YOKE AND ASSEMBLY INDEPENDENT OF THE POTABLE WATER SUPPLY PIPING AND BUILDING PLUMBING. PROVIDE PIPE STANDS OR UNISTRUT WALL STANDOFFS. DO NOT SUPPORT METER ASSEMBLY FROM OTHER PIPING.
12. PROVIDE A WALL PENETRATION AND CONDUIT FOR REMOTE RADIOREAD METER TRANSEIVER UNIT (MXU) DEVICE(S). COORDINATE ROUTING AND WALL PENETRATION LOCATION WITH THE WATER DEPARTMENT. REFER TO WATER STANDARD PLANS 520 AND 530.
13. PROVIDE 1/2" EMT CONDUIT AND SUPPORTS FOR MXU SIGNAL WIRE IF DISTANCE TO WALL PENETRATION EXCEEDS 10 FEET.
14. INSPECTION: CONTACT THE CITY ENGINEER FOR INSPECTION OF THE POTABLE WATER SYSTEM METER ASSEMBLY INSTALLATION
15. REFER TO STD. PLAN 500 AND THE SPECIFICATIONS FOR FLUSHING, HYDROSTATIC TESTING, AND DISINFECTING REQUIREMENTS

 PARK CITY MUNICIPAL CORPORATION <b>WATER</b>	<b>DATE</b>	<b>1-1/2" and 2" METER INSIDE SETTING</b>	<b>STD. PLAN</b>
	10/2020		<b>526 S.2</b>
	<b>REV.</b>		
	0		

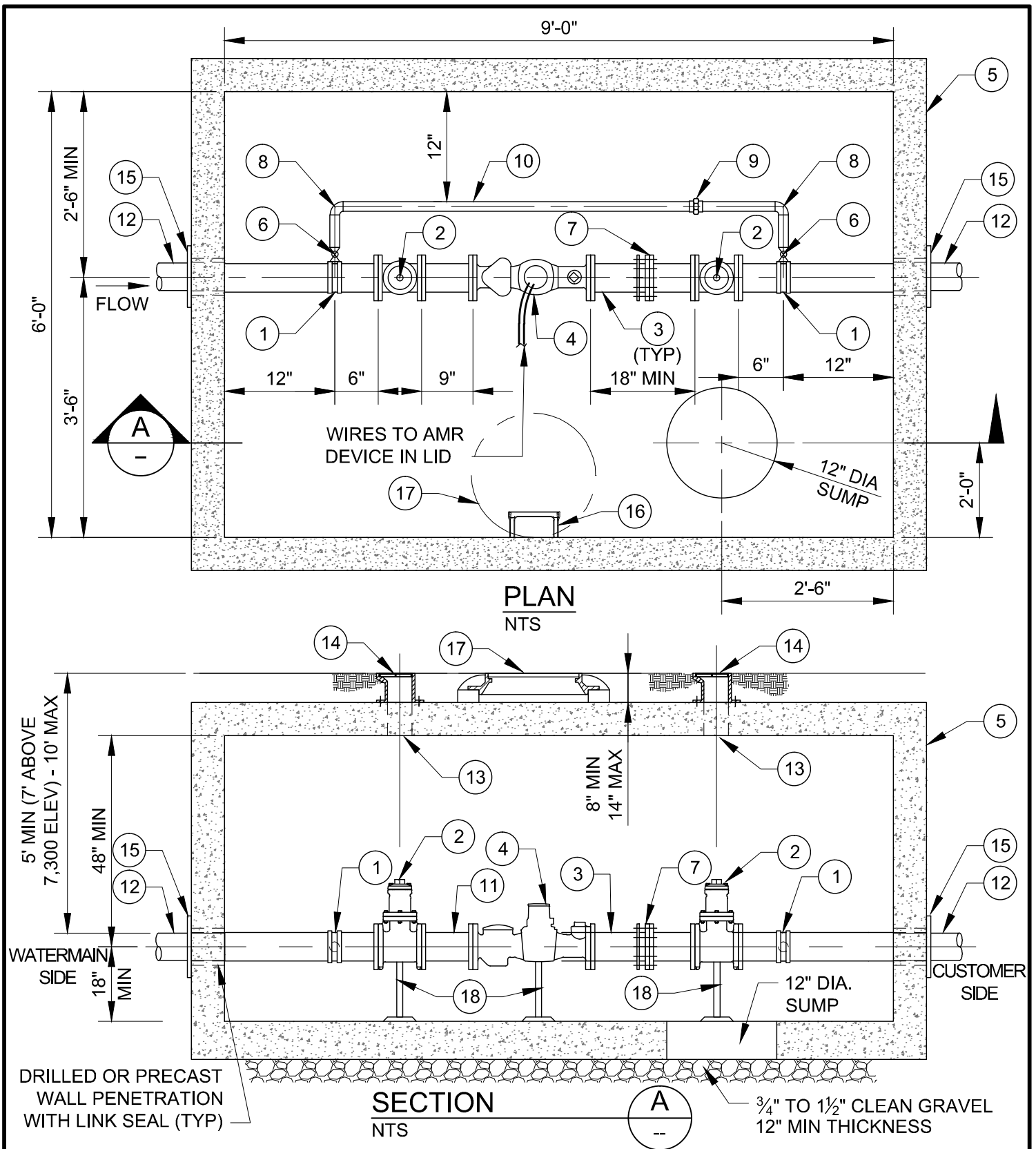

**NOTES:**

1. REFER TO STD. PLAN 520 FOR GENERAL REQUIREMENTS - METER, METER VAULT, AND SERVICE LINE.
2. REFER TO STD. PLAN 527 S FOR LEGEND ITEMS, APPROVED PARTS LIST, AND DETAIL NOTES.

 PARK CITY MUNICIPAL CORPORATION <b>WATER</b>	DATE	<b>3" AND LARGER METER OUTSIDE SETTING</b>	STD. PLAN
	03/2014		<b>527</b>
	REV.		
	0		

## LEGEND AND APPROVED PARTS LIST

ITEM	DESCRIPTION	ACCEPTABLE MANUFACTURER	MODELS
①	2" BRONZE SERVICE SADDLE, DOUBLE STRAP	MUELLER	BR2B SERIES, F.I.P. THREADS
		FORD	202B SERIES, F.I.P. THREADS
②	GATE VALVE, PIPE SIZE, NRS, FLANGED, 2" SQ. OPERATING NUT, AWWA C509	MUELLER	SERIES A-2360
		CLOW	MODEL 2639
③	DUCTILE IRON PIPE SPOOL (2), FLG X PE		
④	METER, SUPPLIED AND INSTALLED BY PCMC	SENSUS	OMNI
⑤	PRECAST CONCRETE VAULT, HS20 RATED		
⑥	2" BRONZE BALL VALVE WITH LOCKING HANDLE, F.I.P., THREADED, 300 PSI RATED	FORD	B11-777Q
⑦	DISMANTLING JOINT	ROMAC	DJ400 OR APPV'D EQUAL
⑧	2" DIA. COPPER 90° ELBOW, SOLDERED, OR BRONZE, F.I.P., THREADED		
⑨	2" DIA. BRONZE UNION, F.I.P., THREADED		
⑩	2" COPPER PIPE, TYPE K, OR BRASS NIPPLE		
⑪	DUCTILE IRON PIPE SPOOL, 9" LENGTH, FLG X FLG		
⑫	DUCTILE IRON PIPE SPOOL, FLG X PE		
⑬	AFTER PIPING INSTALLATION CORE DRILL 6" DIA. HOLE IN VAULT LID DIRECTLY ABOVE GATE VALVES		
⑭	VALVE BOX, FASTEN VALVE BOX TO VAULT WITH TWO EPOXIED ALL-THREAD ROD/NUT OR SST EXP ANCHOR	D & L SUPPLY	M-8065 AND M-8048 TO M-8053
		HILTI	3/8" DIA. ROD SST 316, OR KWIK BOLT 3 3/8"x3" SS316
⑮	THRUST RESTRAINTS	EBBA IRON	MEGALUG SERIES 1100
⑯	POLYPROPYLENE ENCASED GRADE 60 STL STEPS AT 13" C-C, 13-1/2" TREAD WIDTH	M.A. INDUSTRIES OR APPV'D EQUAL	PS2-PFDF
⑰	METER VAULT FRAME AND COVER (STD. PLAN 529)		
⑱	PIPE SUPPORTS, 5 REQ'D (STD. PLAN 533)		
⑲	MXU AND WIRING, SUPPLIED AND INSTALLED BY PCMC		

### DETAIL NOTES

1. REFER TO STD. PLAN 520 FOR GENERAL REQUIREMENTS – METER, METER VAULT, AND SERVICE LINE
2. LOCATE METER VAULT PER APPROVED PLANS AND SET METER BOX PLUMB
3. SST FASTENERS REQUIRED ON ALL FITTINGS
4. NO BYPASS ALLOWED FOR IRRIGATION METERS
5. NO SERVICE LINE REDUCERS OR BENDS WITHIN 5' OF VAULT
6. COORDINATE METER SIZE AND LENGTH WITH CITY PRIOR TO ORDERING MATERIALS
7. REFER TO STD. PLANS 592 AND 593 FOR MANHOLE ADJUSTMENT AND GRADING REQUIREMENTS

 PARK CITY MUNICIPAL CORPORATION <b>WATER</b>	<b>DATE</b>	<b>3" AND LARGER METER OUTSIDE SETTING</b>	<b>STD. PLAN</b>
	10/2020		<b>527 S</b>
	<b>REV.</b>		

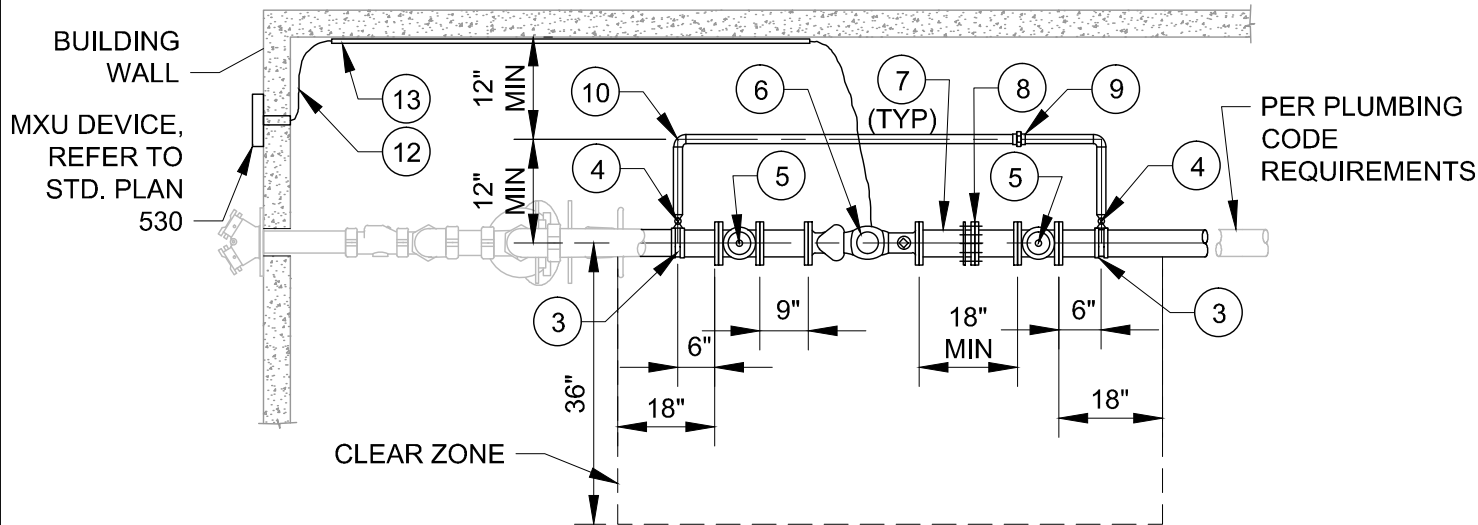

**PLAN**  
NTS

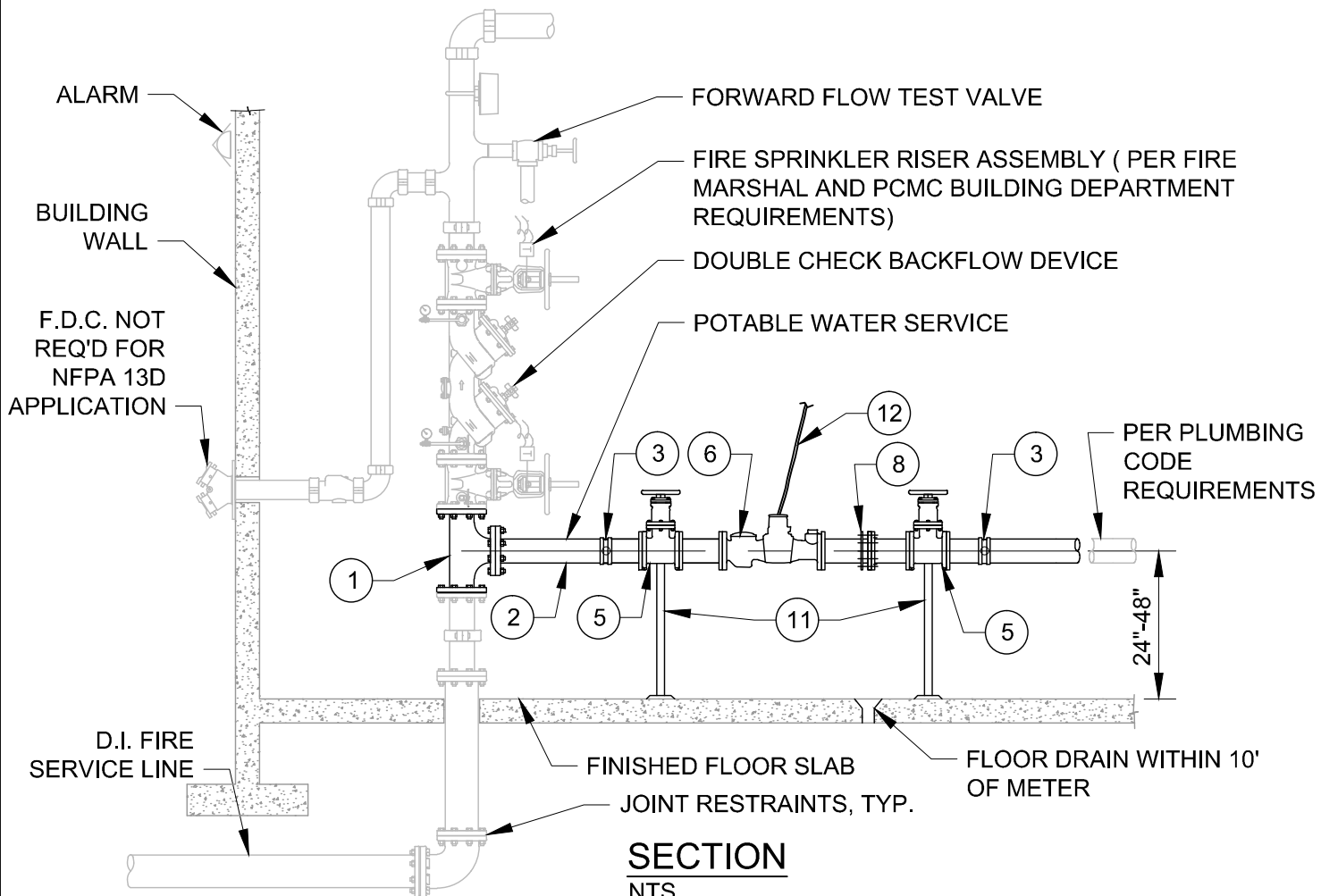

**SECTION**  
NTS

**NOTES:**

1. REFER TO STD. PLAN 520 FOR GENERAL REQUIREMENTS - METER, METER VAULT, AND SERVICE LINE.
2. REFER TO STD. PLAN 528 S FOR LEGEND ITEMS, APPROVED PARTS LIST, AND DETAIL NOTES.

 PARK CITY MUNICIPAL CORPORATION <b>WATER</b>	DATE	<b>3" AND LARGER METER INSIDE SETTING</b>	STD. PLAN
	05/2014		<b>528</b>
	REV.		
	0		

## LEGEND AND APPROVED PARTS LIST

ITEM	DESCRIPTION	ACCEPTABLE MANUFACTURER	MODELS
①	DUCTILE IRON TEE, FLG., PRESSURE CLASS 350, CEMENT-MORTAR LINED, ASPHALTIC INTERIOR COATING, AWWA C150 / C151 / C104	U.S. PIPE PACIFIC STATES	
		U.S. PIPE PACIFIC STATES	
②	DUCTILE IRON PIPE SPOOL, FLG. X FLG., 3" TO 12" DIAMETER, FULL BODY, PRESSURE CLASS 350, CEMENT-MORTAR LINED, ASPHALTIC INTERIOR COATING, AWWA C150 / C151 / C104	U.S. PIPE PACIFIC STATES	
③	2" BRONZE SERVICE SADDLE, DOUBLE STRAP	MUELLER	BR2B SERIES, FIP THDS
		FORD	STYLE 202B, FIP THDS
④	2" BRONZE BALL VALVE WITH LOCKING HANDLE, F.I.P., THREADED, 300 PSI RATED, LEAD FREE	FORD	B11-777Q
⑤	GATE VALVE, PIPE SIZE, NRS WITH HANDWHEEL, FLANGED, 2" SQ. OPERATING NUT, AWWA C509	MUELLER	SERIES A-2360
		CLOW	MODEL 2639
⑥	METER, SUPPLIED AND INSTALLED BY PCMC	SENSUS	OMNI
⑦	DUCTILE IRON PIPE SPOOL (2), FLG X PE		
⑧	DISMANTLING JOINT, WITH RESTRAINING BOLTS	ROMAC	DJ400 OR APPV'D EQUAL
⑨	2" BRONZE UNION, F.I.P., THREADED, LEAD FREE		
⑩	2" COPPER PIPE, TYPE K, WITH COPPER 90° ELBOW, SOLDERED, OR BRASS NIPPLE BRONZE, F.I.P., WITH THREADED 90° ELBOW (NO GALVANIZED MATERIALS)		
⑪	PIPE SUPPORTS, 2 REQ'D ON MAIN SERVICE LINE AND 2 REQ'D ON BYPASS SERVICE		
⑫	MXU AND WIRING, SUPPLIED AND INSTALLED BY PCMC		
⑬	1/2" EMT CONDUIT FOR MXU WIRING, AS REQUIRED		



PARK CITY MUNICIPAL CORPORATION  
**WATER**

**DATE**

10/2020

**REV.**

0

**3" AND LARGER METER  
INSIDE SETTING**

**STD. PLAN**

**528 S.1**

## DETAIL NOTES

1. USE OF AN INSIDE WATER METER REQUIRES CITY ENGINEER APPROVAL. REFERENCE WATER STANDARD PLAN 520 FOR APPLICABLE CONDITIONS.
2. FIRE SPRINKLER RISER WITH POTABLE WATER SERVICE: A SITE SPECIFIC DESIGN IS REQUIRED. THE FIRE PROTECTION SPRINKLER SYSTEM AND POTABLE WATER SYSTEM DESIGN SHALL BE APPROVED BY THE FIRE MARSHAL AND THE PARK CITY BUILDING DEPARTMENT. THE POTABLE WATER SERVICE CONNECTION AND METER ASSEMBLY DESIGN SHALL BE APPROVED BY THE PARK CITY BUILDING DEPARTMENT AND THE CITY ENGINEER. DESIGN AND CONSTRUCTION SHALL COMPLY WITH APPLICABLE BUILDING AND PLUMBING CODES.
3. BACKFLOW PREVENTION: PROVIDE A DOUBLE CHECK BACKFLOW ASSEMBLY (DCBA) OR REDUCED PRESSURE PRINCIPLE BACKFLOW ASSEMBLY (RPBA) ON THE FIRE SPRINKLER RISER ASSEMBLY. STYLE TO BE DETERMINED BY THE BUILDING AND WATER DEPARTMENT BASED ON DEGREE OF HAZARD POSED BY FIRE SPRINKLER PROTECTION SYSTEM. BEFORE A CERTIFICATE OF OCCUPANCY CAN BE ISSUED BY THE BUILDING DEPARTMENT, BACKFLOW ASSEMBLY TESTING FOR PROPER OPERATION (PER CITY REQUIREMENTS BY A CERTIFIED TESTER RECOGNIZED BY THE CITY) IS REQUIRED AND A REPORT SUBMITTED.
4. CONNECTIONS TO THE WATER SYSTEM ARE NOT PERMITTED PRIOR TO THE POTABLE WATER METER ASSEMBLY OR THE FIRE SPRINKLER RISER BACKFLOW ASSEMBLY. THIS INCLUDES OUTSIDE IRRIGATION SUPPLY.
5. CLEARANCES: PROVIDE ADEQUATE CLEARANCES FROM FIRE RISER AND AROUND WATER METER ASSEMBLY. MAINTAIN: 9" MINIMUM FROM WALL TO FACE OF POTABLE WATER PIPING  
18" CLEAR ON EACH SIDE OF METER ASSEMBLY  
36" CLEAR IN FRONT OF METER ASSEMBLY
6. LOCATE METER ASSEMBLY TWO (2) TO FOUR (4) FEET ABOVE THE FLOOR. POSITION METER HORIZONTAL WITH DIAL POINTING UP.
7. VERIFY METER LAY LENGTH WITH WATER DEPARTMENT PRIOR TO INSTALLING PIPING
8. PROVIDE ISOLATION VALVES AT METER INLET AND OUTLET
9. FOR MULTIPLE METERS PROVIDE A MANIFOLD WITH A MAIN VALVE PRIOR TO THE MANIFOLD AND INDIVIDUAL VALVES LOCATED PRIOR TO AND AFTER METERS.
10. PROVIDE A FLOOR DRAIN IN THE FIRE RISER ROOM WITHIN 10 FEET OF THE WATER METER LOCATION.
11. PROVIDE PIPE LABELS ON THE POTABLE WATER LINE BETWEEN THE FIRE RISER AND THE WATER METER DESIGNATING PIPE AS "POTABLE WATER".
12. PROVIDE PIPE ANCHORAGE TO SUPPORT METER ASSEMBLY INDEPENDENT OF THE POTABLE WATER SUPPLY PIPING AND BUILDING PLUMBING. PROVIDE PIPE STANDS OR UNISTRUT WALL STANDOFFS. DO NOT SUPPORT METER ASSEMBLY FROM OTHER PIPING.
13. PROVIDE A WALL PENETRATION AND CONDUIT FOR REMOTE RADIOREAD METER TRANSEIVER UNIT (MXU) DEVICE(S). COORDINATE ROUTING AND WALL PENETRATION LOCATION WITH THE WATER DEPARTMENT. REFERENCE WATER STANDARD PLANS 520 AND 530.
14. PROVIDE 1/2" EMT CONDUIT AND SUPPORTS FOR MXU SIGNAL WIRE IF DISTANCE TO WALL PENETRATION EXCEEDS 10 FEET.
15. INSPECTION: CONTACT THE CITY ENGINEER FOR INSPECTION OF THE POTABLE WATER SYSTEM METER ASSEMBLY INSTALLATION.
16. REFER TO STD. PLAN 500 AND THE SPECIFICATIONS FOR FLUSHING, HYDROSTATIC TESTING, AND DISINFECTING REQUIREMENTS
17. BUILDING OWNER IS RESPONSIBLE TO HAVE THE BACKFLOW PREVENTER FLOW TESTED AND INSPECTED INTERNALLY AT LEAST ONCE PER YEAR, OR MORE AS CONDITIONS WARRANT, IN ACCORDANCE WITH NFPA 13 AND NFPA 25 AND A REPORT SUBMITTED TO THE PARK CITY BUILDING DEPARTMENT

 PARK CITY MUNICIPAL CORPORATION <b>WATER</b>	<b>DATE</b>	<b>3" AND LARGER METER INSIDE SETTING</b>	<b>STD. PLAN</b>
	10/2020		<b>528 S.2</b>
	<b>REV.</b>		
	0		

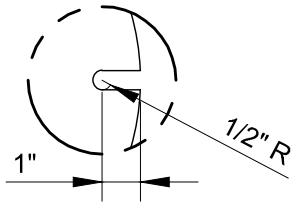

PLAN VIEW A

4 1/2" DIA. RECESS  
W/ 2" TAP

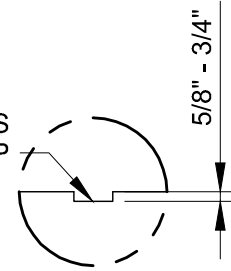

PLAN VIEW B

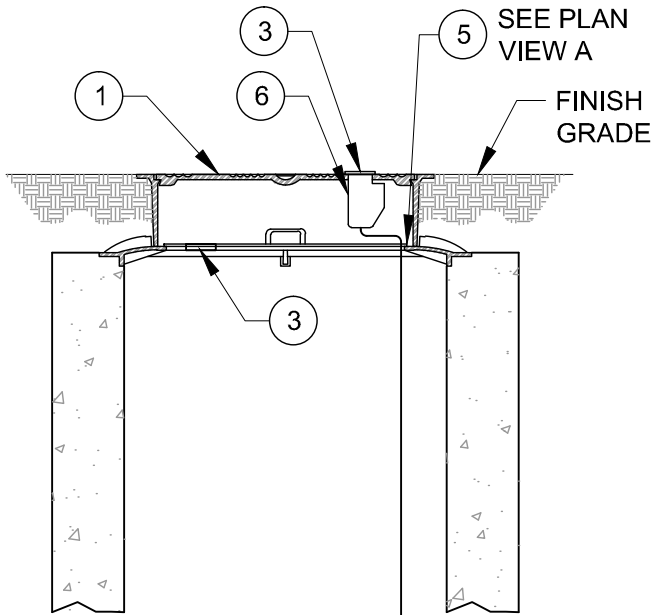

LANDSCAPE AREA

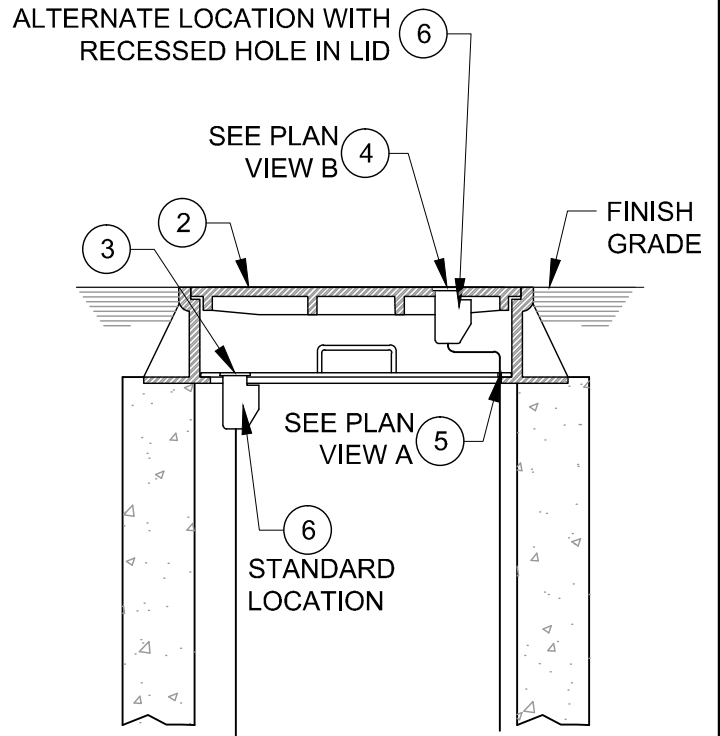

PAVEMENT AREA



PARK CITY MUNICIPAL CORPORATION  
**WATER**

DATE

03/2014

REV.

0

**METER VAULT FRAME AND  
COVER / MXU DEVICE  
LOCATION**

STD. PLAN

**529**



## LEGEND AND APPROVED PARTS LIST

ITEM	DESCRIPTION	ACCEPTABLE MANUFACTURER	MODELS
①	METER VAULT FRAME AND COVER, MARKED "WATER"	D&L SUPPLY	L-2320, OR APPROVED EQUAL
②	METER VAULT FRAME AND COVER, TRAFFIC RATED, MARKED "WATER"	D&L SUPPLY	A-1019, OR APPROVED EQUAL
③	2" TAP AND PLUG, REQUIRED	FORD OR APPROVED EQUAL	PLUG: PTP-3-25
④	2" TAP WITH RECESSED PLUG, REQUIRED (PLAN VIEW 'B')		
⑤	NOTCH INNER FROST FREE LID FOR SIGNAL WIRE (PLAN VIEW 'A')		
⑥	MXU AND WIRING, SUPPLIED AND INSTALLED BY PCMC		
⑦	METER VAULT, MATERIALS VARY		

### DETAIL NOTES

1. REFER TO STD. PLAN 592 AND 593 FOR METER VAULT ADJUSTMENT AND GRADING REQUIREMENTS
2. PROVIDE TAPS FOR STANDARD AND ALTERNATE MXU LOCATIONS
3. PROVIDE PLUGS FOR ALL OPENINGS
4. REMOVE ALL BURRS FROM TAPS AND NOTCHES
5. REFER TO STD PLAN 530 FOR REMOTE MXU REQUIREMENTS

 PARK CITY MUNICIPAL CORPORATION <b>WATER</b>	<b>DATE</b>	<b>METER VAULT                      FRAME AND COVER /                      MXU DEVICE LOCATION</b>	<b>STD. PLAN</b>
	10/2020		<b>529 S</b>
	<b>REV.</b>		
	0		

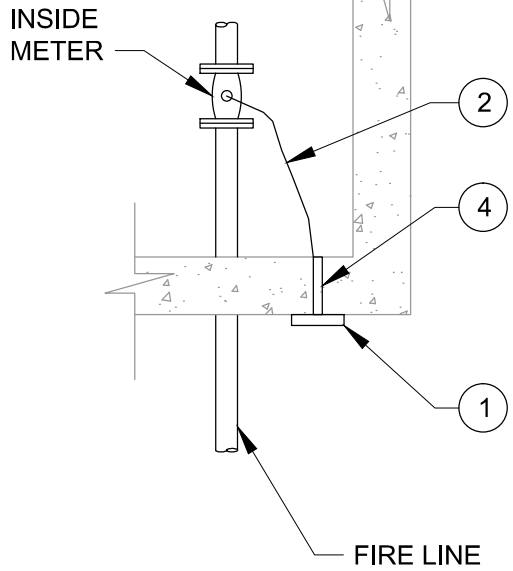

INSIDE METER

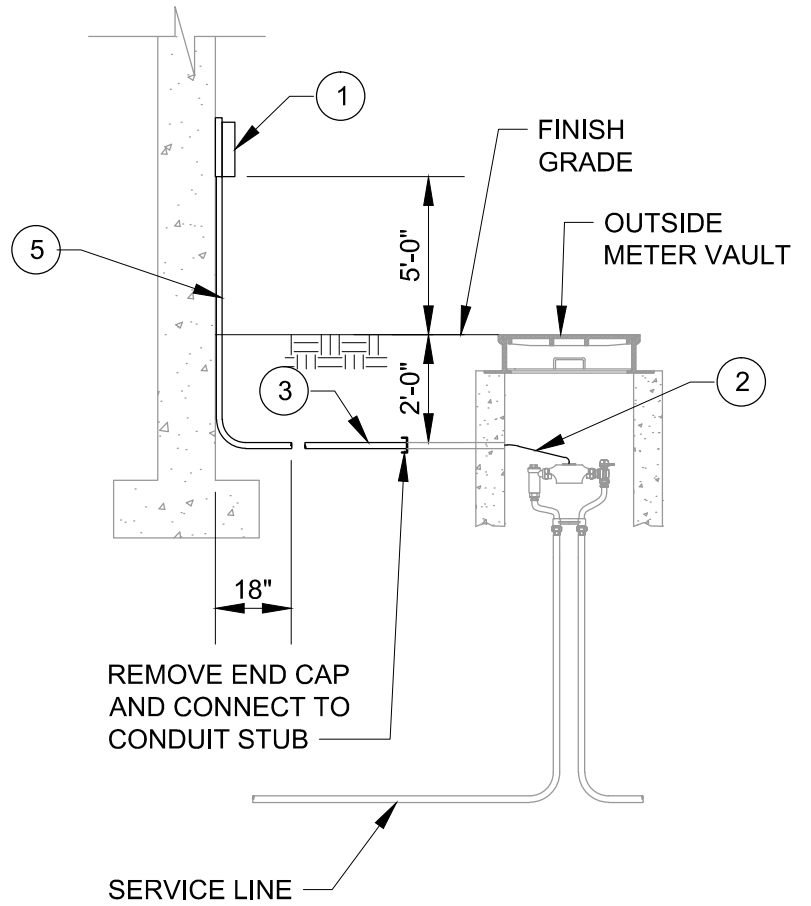

OUTSIDE METER

LEGEND	
ITEM	DESCRIPTION
①	REMOTE RADIO READ MXU, 6"X6", DEVICE SURFACE MOUNT, BY PCMC
②	MXU SIGNAL WIRE, SUPPLIED AND INSTALLED BY PCMC
③	3/4" PVC NEMA TC-2 CONDUIT BY CUSTOMER
④	WALL PENETRATION, BY CUSTOMER
⑤	3/4" GALVANIZED RIGID STEEL CONDUIT, BY CUSTOMER

NOTES:

- REFER TO STD. PLAN 520 FOR GENERAL REQUIREMENTS - METER, METER VAULT, AND SERVICE LINE.

 PARK CITY MUNICIPAL CORPORATION <b>WATER</b>	DATE	<b>REMOTE MXU DEVICE</b>	STD. PLAN
	03/2014		<b>530</b>
	REV.		
	0		

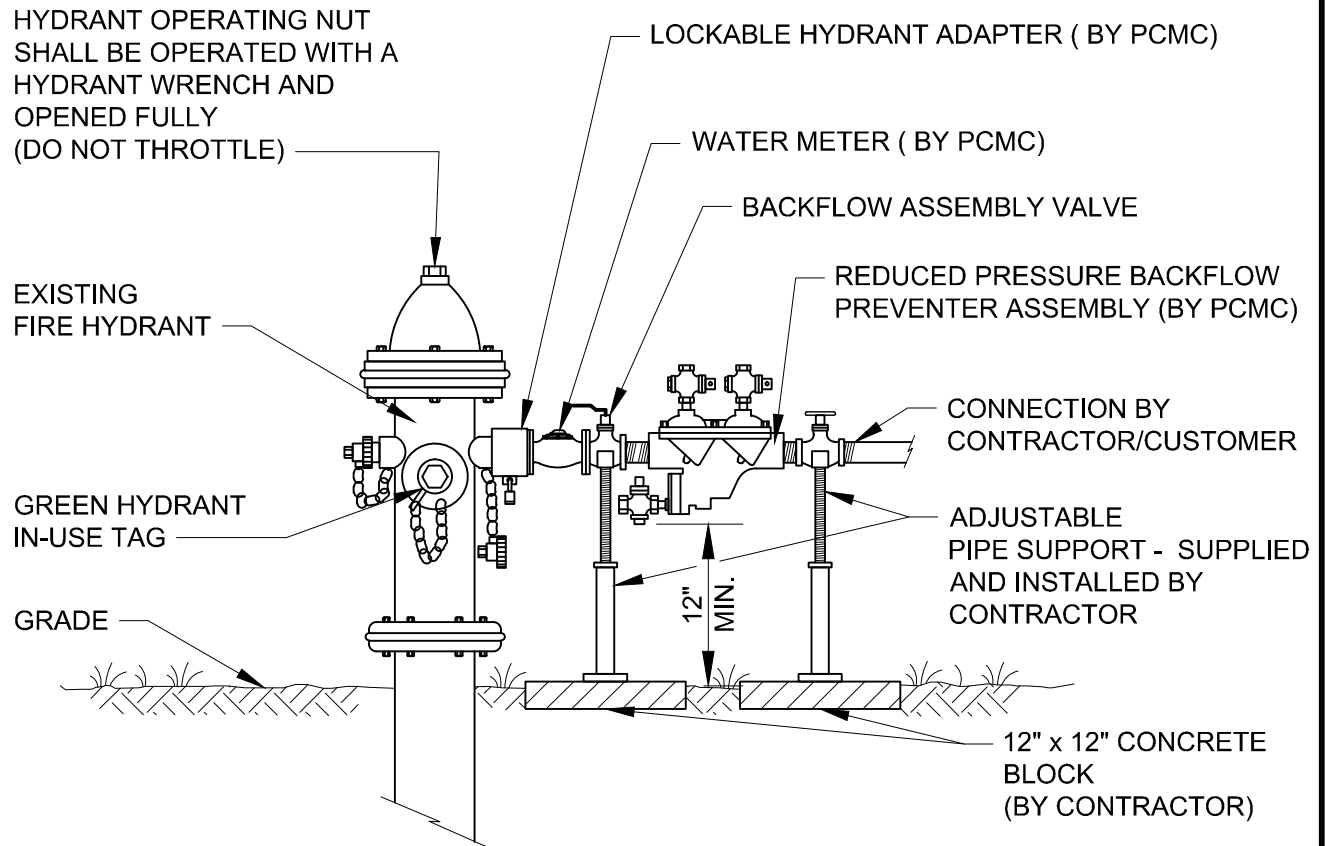

**NOTES:**

1. USE OF A PCMC FIRE HYDRANT FOR OBTAINING CONSTRUCTION WATER REQUIRES A VALID CUSTOMER WATER SERVICE AGREEMENT. THE AGREEMENT CAN BE OBTAINED FROM THE PUBLIC WORKS DEPARTMENT. A DEPOSIT FEE IS REQUIRED.
2. CONTRACTOR (CUSTOMER) IS RESPONSIBLE TO PICK UP THE PCMC PROVIDED HYDRANT METER ASSEMBLY FROM THE PUBLIC WORKS DEPARTMENT. COORDINATE PICK UP 24 HOURS PRIOR TO ARRIVAL.
3. CONTRACTOR SHALL BE RESPONSIBLE TO INSTALL AND PROPERLY SUPPORT THE PCMC PROVIDED HYDRANT METER ASSEMBLY. PRIOR TO THE PLACING THE ASSEMBLY IN SERVICE THE FOLLOWING IS REQUIRED:
  - 1) ASSEMBLY INSTALLATION IS TO BE INSPECTED BY A WATER DEPARTMENT REPRESENTATIVE. ALLOW 24 HOURS NOTICE FOR AN INSPECTION (NO WEEKEND OR HOLIDAY INSPECTIONS). ONCE PROPER INSTALLATION IS VERIFIED, THE WATER DEPARTMENT REPRESENTATIVE SHALL UNLOCK THE ASSEMBLY AND ACTIVE THE HYDRANT.
  - 2) CONTRACTOR SHALL NOTIFY THE PARK CITY FIRE SERVICE DISTRICT OFFICE OF THE HYDRANT CONNECTION
4. FULLY OPEN THE FIRE HYDRANT VALVE PRIOR TO OPERATION. DO NOT USE THE FIRE HYDRANT VALVE FOR THROTTLING, USE THE BACKFLOW ASSEMBLY VALVE. DO NOT CLOSE VALVES ON THE ASSEMBLY OR THE DISCHARGE LINE QUICKLY.
5. CONTRACTOR SHALL PROTECT THE HYDRANT METER ASSEMBLY FROM DAMAGE, THEFT, AND MISUSE.
6. CONTRACTOR IS RESPONSIBLE FOR ANY AND ALL WATER CONSUMPTION.
7. CONTRACTOR SHALL NOTIFY PCMC WATER DEPARTMENT, REMOVE, AND RETURN THE HYDRANT METER ASSEMBLY WHEN HYDRANT USE IS COMPLETE. RELOCATION OF THE HYDRANT METER ASSEMBLY REQUIRES PRIOR NOTIFICATION TO THE WATER DEPARTMENT AND A MODIFICATION TO THE CUSTOMER SERVICE AGREEMENT.
8. CONTRACTOR IS RESPONSIBLE FOR ANY AND ALL DAMAGE TO METER AND HYDRANT WHILE IN USE

 PARK CITY MUNICIPAL CORPORATION <b>WATER</b>	DATE	<b>TEMPORARY HYDRANT METER ASSEMBLY</b>	STD. PLAN
	03/2014		<b>531</b>
	REV.		
	0		