

LOW/HIGH GRADE ADJUSTMENT

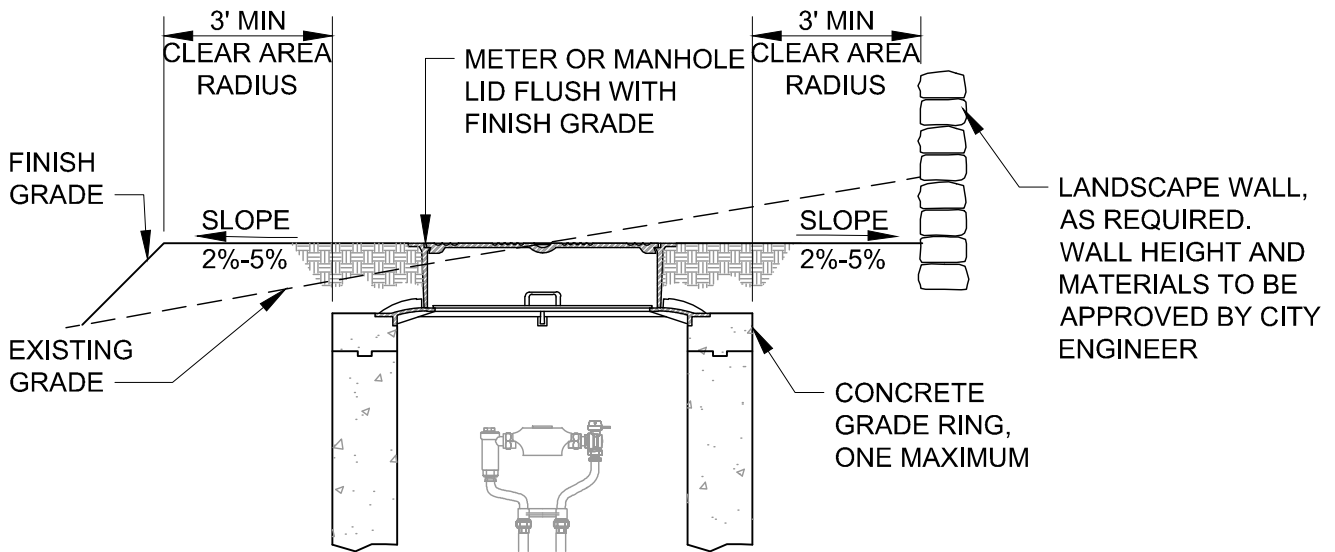

SLOPE GRADE ADJUSTMENT

NOTES:

1. REFER TO STD. PLAN 520 FOR GENERAL REQUIREMENTS - METER, METER VAULT, AND SERVICE LINE.
2. METER YOKE DEPTH MUST MEET THE METER VAULT REQUIREMENTS. (PLAN 521 THRU 525)
3. METER LID HIGHER THAN THE SURROUNDING FINISH GRADE:
RAISE GRADE SURROUNDING METER LID TO THE TOP OF METER LID.
PROVIDE DRAINAGE AWAY FROM THE METER LID.
4. METER LID LOWER THAN THE SURROUNDING FINISH GRADE:
RAISE METER VAULT AND COMPONENTS TO MEET METER VAULT REQUIREMENTS.

 PARK CITY MUNICIPAL CORPORATION WATER	DATE	METER VAULT AND WATER MANHOLE GRADING LANDSCAPE AREAS	STD. PLAN	
			3/2014	
	REV.			
			0	592

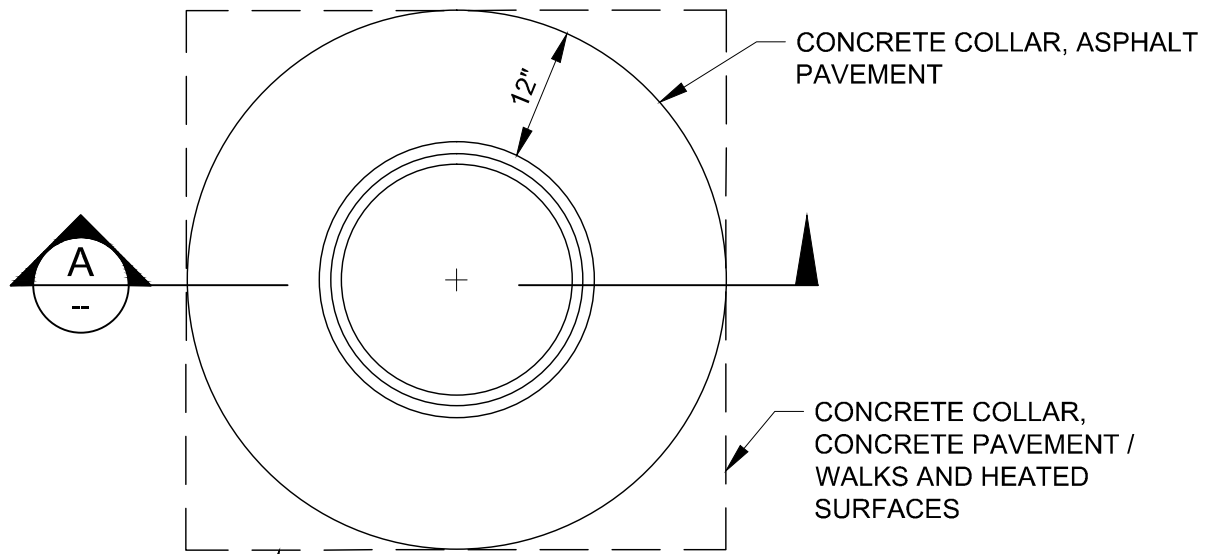

PLAN

PROVIDE HEATING SYSTEM DISCONNECT AT COLLAR LIMITS. 24" COLLAR REQUIRED FOR 4' AND 5' MANHOLES AND VAULTS

ASPHALT PAVEMENT:
COLLAR SET ¼" MIN. TO ½" MAX. BELOW PAVEMENT LIP ALL AROUND.

CONCRETE PAVEMENT:
SET COLLAR FLUSH WITH PAVEMENT LIP

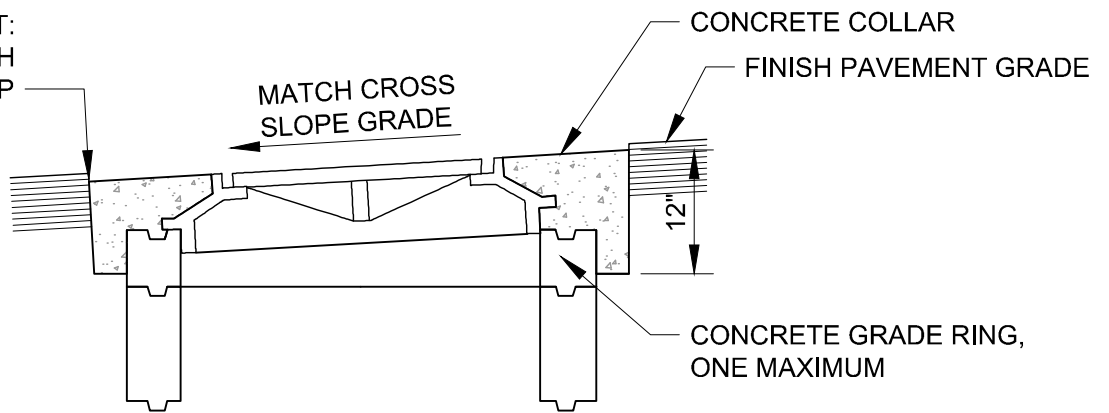

SECTION
NTS

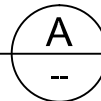

PARK CITY MUNICIPAL CORPORATION
WATER

DATE

3/2014

REV.

0

**METER VAULT AND
WATER MANHOLE COLLAR
PAVEMENT AREAS**

STD. PLAN

593

¹ WATER SERVICE LINE FLOW CHART

SYSTEM PRESSURE (PSI)	² MIN. SYSTEM RESIDUAL FIRE FLOW PRESSURE (PSI)	AVAILABLE PRESSURE DROP (PSI)	SERVICE SIZE (INCH)							
			0.75		1		1.5		2	
			AVAILABLE FLOW WITHOUT METER (GPM)	* RATED FLOW THROUGH METER (GPM)	AVAILABLE FLOW WITHOUT METER (GPM)	* RATED FLOW THROUGH METER (GPM)	AVAILABLE FLOW WITHOUT METER (GPM)	* RATED FLOW THROUGH METER (GPM)	AVAILABLE FLOW WITHOUT METER (GPM)	* RATED FLOW THROUGH METER (GPM)
150	20	130	53	30	113	50	328	100	700	160
145	20	125	52	30	111	50	322	100	686	160
140	20	120	51	30	108	50	315	100	671	160
135	20	115	50	30	106	50	307	100	655	160
130	20	110	48	30	103	50	300	100	640	160
125	20	105	47	30	101	50	293	100	624	160
120	20	100	46	30	98	50	285	100	608	160
115	20	95	45	30	95	50	277	100	591	160
110	20	90	43	30	93	50	269	100	574	160
105	20	85	42	30	90	50	261	100	557	160
100	20	80	41	30	87	50	253	100	539	160
95	20	75	39	30	84	50	244	100	520	160
90	20	70	38	30	81	50	235	100	501	160
85	20	65	36	30	78	50	226	100	482	160
80	20	60	35	30	74	50	216	100	461	160
75	20	55	33	30	71	50	206	100	440	160
70	20	50	32	28	67	50	196	100	418	160
65	20	45	30	26	64	50	185	100	395	160
60	20	40	28	24	60	50	174	100	370	160
55	20	35	26	23	56	48	162	100	345	160
50	20	30	24	21	51	44	149	100	317	160
45	20	25	22	19	46	40	135	100	287	160
40	20	20	19	17	41	36	119	88	255	158
35	20	15	16	14	35	30	102	76	218	135
30	20	10	13	12	28	24	82	62	175	110
25	20	5	9	8	19	17	56	43	120	77
20	20	0	0	0	0	0	0	0	0	0

NOTES:

- REFER TO STD. PLAN 594.2 FOR NOTES AND REFERENCES.

 PARK CITY MUNICIPAL CORPORATION WATER	DATE	WATER SERVICE LINE FLOW CHART	STD. PLAN
	4/2014		594.1
	REV.		
	0		

* VALUES DERIVED FROM SR WATER METERS TYPICAL PERFORMANCE CURVES AND THE METERS AWWA MAXIMUM CAPACITY

ASSUMED:

L (FT) = 40.0 (MAX LENGTH IN FEET FROM MAIN TO METER)

C = 135.0 (OLDER HDPE PIPE)

WHEN USED TO CALCULATE THE PRESSURE DROP USING THE US CUSTOMARY UNITS SYSTEM, THE EQUATION IS:

$$P_d = \frac{4.52 * L * Q^{1.85}}{C^{1.85} * d^{4.87}}$$

WHERE:

P_D = PRESSURE DROP OVER A LENGTH OF PIPE, PSIG (POUNDS PER SQUARE INCH GAUGE PRESSURE)

L = LENGTH OF PIPE, FT (FEET)

Q = FLOW, GPM (GALLONS PER MINUTE)

d = INSIDE PIPE DIAMETER, IN (INCHES)

C = HAZEN WILLIAMS COEFFICIENT OF FRICTION

NOTES:

1. THIS TABLE IS FOR REFERENCE PURPOSES ONLY AND REPRESENTS MAXIMUM ANTICIPATED FLOW TO THE POINT OF CONNECTION (40 FOOT MAXIMUM LENGTH) WITHOUT ADDITIONAL VALVES AND PIPING. HOMEOWNERS, ARCHITECTS, ENGINEERS, FIRE SPRINKLER DESIGNERS, ETC., ARE RESPONSIBLE TO VERIFY EXISTING WATER SYSTEM PRESSURES PRIOR TO DESIGN AND INCORPORATE THE INFORMATION INTO THE WATER SERVICE AND FIRE SERVICE LINE DESIGN. ADDITIONAL PRESSURE LOSSES WILL OCCUR THROUGH ADDITIONAL REQUIRED VALVES AND PIPING.
2. THE MINIMUM WATER PRESSURE AT THE POINT OF CONNECTION SHALL BE ABOVE 20 PSI WITH FIRE FLOW AND PEAK DAY DEMANDS, ABOVE 30 PSI WITH PEAK INSTANTANEOUS DEMANDS, AND ABOVE 40 PSI WITH PEAK DAY DEMANDS. SEE UTAH ADMINISTRATIVE CODE R309-105-9. MINIMUM WATER PRESSURE.
3. INDIVIDUAL HOME BOOSTER PUMPS SHALL NOT BE ALLOWED FOR ANY INDIVIDUAL SERVICE FROM THE PUBLIC WATER SUPPLY MAIN, SEE UTAH ADMINISTRATIVE CODE R309-105-9 AND R309-540-5(4)(C)

 PARK CITY MUNICIPAL CORPORATION WATER	DATE	WATER SERVICE LINE FLOW CHART	STD. PLAN
	4/2014		594.2
	REV.		
	0		

DOUBLE CHECK VALVE OR REDUCED PRESSURE PRINCIPLE BACKFLOW PREVENTER (SEE NOTES 2 AND 3)

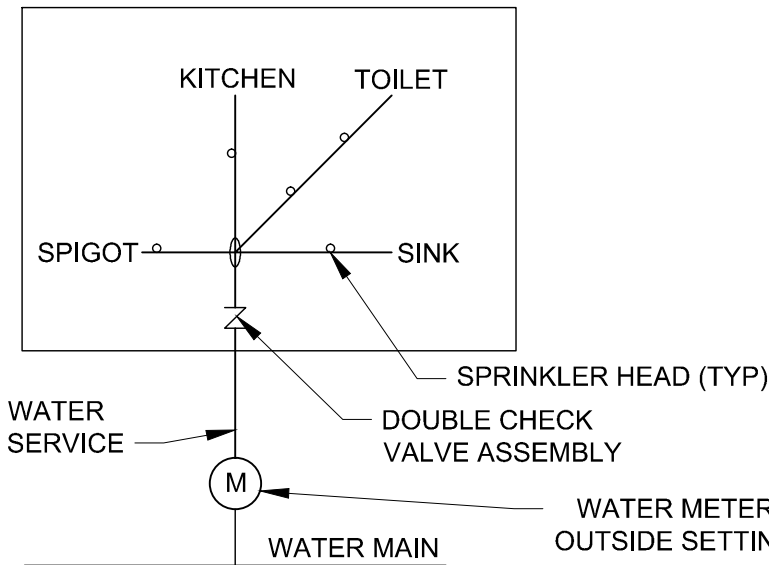

OPTION 1
MULTI-PURPOSE PIPING SYSTEM

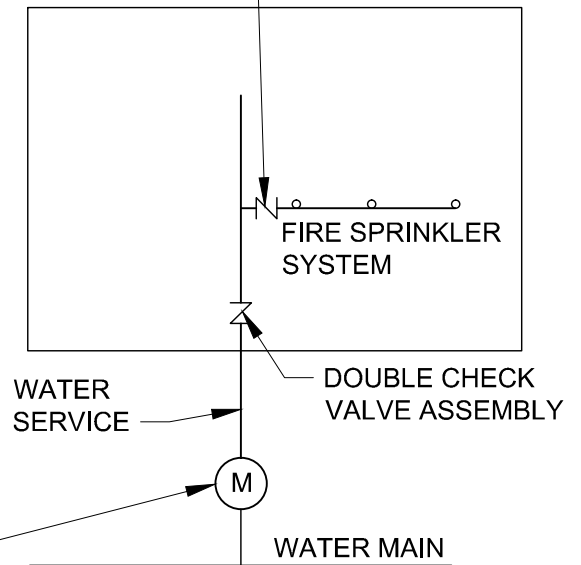

OPTION 2
BRANCHED

NOTES:

1. MULTI-PURPOSE RESIDENTIAL FIRE SPRINKLER PROTECTION PLUMBING SYSTEM SHALL MEET NFPA 13D REQUIREMENTS AND PARK CITY BUILDING DEPARTMENT AND FIRE MARSHAL APPROVAL. OPTION SHALL BE APPROVED BY THE PARK CITY BUILDING DEPARTMENT, CITY ENGINEER, AND FIRE MARSHAL PRIOR TO SYSTEM DESIGN.
2. DESIGN AND CONSTRUCTION SHALL COMPLY WITH APPLICABLE BUILDING AND PLUMBING CODES.
3. BACKFLOW PREVENTION: BACKFLOW PREVENTION IS REQUIRED FOR BOTH OPTIONS. PROVIDE A DOUBLE CHECK BACKFLOW ASSEMBLY (DCBA) OR REDUCED PRESSURE PRINCIPLE BACKFLOW ASSEMBLY (RPBA) ON THE FIRE SPRINKLER RISER ASSEMBLY. BACKFLOW PREVENTER STYLE TO BE DETERMINED BY THE BUILDING AND WATER DEPARTMENT BASED ON DEGREE OF HAZARD POSED BY FIRE SPRINKLER PROTECTION SYSTEM. A FIRE SPRINKLER PROTECTION SYSTEM WHICH CONTAINS CHEMICAL ADDITIVES OR A FIRE PUMP SYSTEM REQUIRES A REDUCED PRESSURE PRINCIPAL BACKFLOW PREVENTER (RPBA) STYLE.
4. BEFORE A CERTIFICATE OF OCCUPANCY CAN BE ISSUED BY THE BUILDING DEPARTMENT, BACKFLOW ASSEMBLY TESTING FOR PROPER OPERATION (PER CITY REQUIREMENTS BY A CERTIFIED TESTER RECOGNIZED BY THE CITY) IS REQUIRED AND A REPORT SUBMITTED.
5. FIRE SPRINKLER PROTECTION SYSTEMS CONTAINING FIRE PUMPS REQUIRES SITE SPECIFIC DESIGN AND APPROVAL BY THE CITY ENGINEER, PARK CITY BUILDING DEPARTMENT, WATER DEPARTMENT, AND FIRE MARSHAL PRIOR TO BUILDING APPROVAL. FIRE PUMP SYSTEM SHALL BE LOCATED ON THE BUILDING SIDE OF THE WATER OUTSIDE OF THE WATER METER VAULT. REFER TO STD. PLAN 520 FOR REQUIREMENTS.

 PARK CITY MUNICIPAL CORPORATION WATER	DATE	NFPA 13D RESIDENTIAL SPRINKLER SERVICES	STD. PLAN
	2/2014		595
	REV.		
	0		

DETAIL NOTES

1. REFER TO STD. PLAN 520 FOR GENERAL REQUIREMENTS – METER, METER VAULT, AND SERVICE LINE
2. REFER TO STD. PLANS FOR WATER SERVICE REQUIREMENTS
3. REFER TO THE STATE OF UTAH, DEPARTMENT OF ENVIRONMENTAL QUALITY DIVISION OF DRINKING WATER LIST OF APPROVED BACKFLOW PREVENTION DEVICES. APPROVED DEVICES CAN BE FOUND AT THE FOLLOWING STATE OF UTAH WEBSITE:
[HTTP://DRINKINGWATER.UTAH.GOV/DOCUMENTS/COMPLIANCE/APPENDIXB_1-19-11.PDF](http://drinkingwater.utah.gov/documents/compliance/appendixb_1-19-11.pdf)
4. BACKFLOW ASSEMBLY SELECTION AND INSTALLATION SHALL CONFORM TO THE APPROVED INSTALLATION ORIENTATION ONLY.
5. ALL BACKFLOW PREVENTION DEVICES USED WITHIN THE STATE OF UTAH SHALL HAVE THIRD PARTY CERTIFICATION AS MENTIONED ABOVE.
6. ALL BACKFLOW PREVENTERS HAVE TO BE TESTED PERIODICALLY TO ENSURE THAT THEY ARE FUNCTIONING PROPERLY. A VISUAL CHECK OF AIR GAPS IS SUFFICIENT, BUT MECHANICAL BACKFLOW PREVENTERS HAVE TO BE TESTED BY A STATE CERTIFIED BACKFLOW SPECIALIST, WITH PROPERLY CALIBRATED GAUGE EQUIPMENT. TO OBTAIN A LIST OF STATE CERTIFIED TESTERS EITHER CALL US OR REFER TO THE STATE OF UTAH WEBSITE PAGE OF BACKFLOW TESTERS.
[HTTP://WWW.DRINKINGWATER.UTAH.GOV/DOCUMENTS/COMPLIANCE/BACKFLOW_TECHNICIANS_CO M M E R _ A V A I L . P D F](http://www.drinkingwater.utah.gov/documents/compliance/backflow_technicians_cmmmer_avail.pdf)
7. FIRE SPRINKLER SYSTEM PUMPS, INTEGRAL TO THE FIRE SPRINKLER PIPING, TO MEET FIRE SPRINKLER PRESSURE DESIGN REQUIREMENTS ARE CONSIDERED OUTSIDE THE INTENT OF UTAH DDW REGULATION R309-550-11(3) AND DO NOT REQUIRE APPROVAL OF THE DDW IF THEIR INSTALLATION CONFORMS TO UTAH ADOPTED PLUMBING CODE AND NATIONAL FIRE PROTECTION ASSOCIATION (NFPA) 13 D. PUMPS SHALL BE CONNECTED ON THE BUILDING SIDE OF THE WATER METER VAULT AND SHALL BE APPROVED BY THE CITY ENGINEER AND BUILDING DEPARTMENT.

 PARK CITY MUNICIPAL CORPORATION WATER	DATE	NFPA 13D RESIDENTIAL FIRE SPRINKLER LINES	STD. PLAN
	5/2014		595 S
	REV.		
	0		

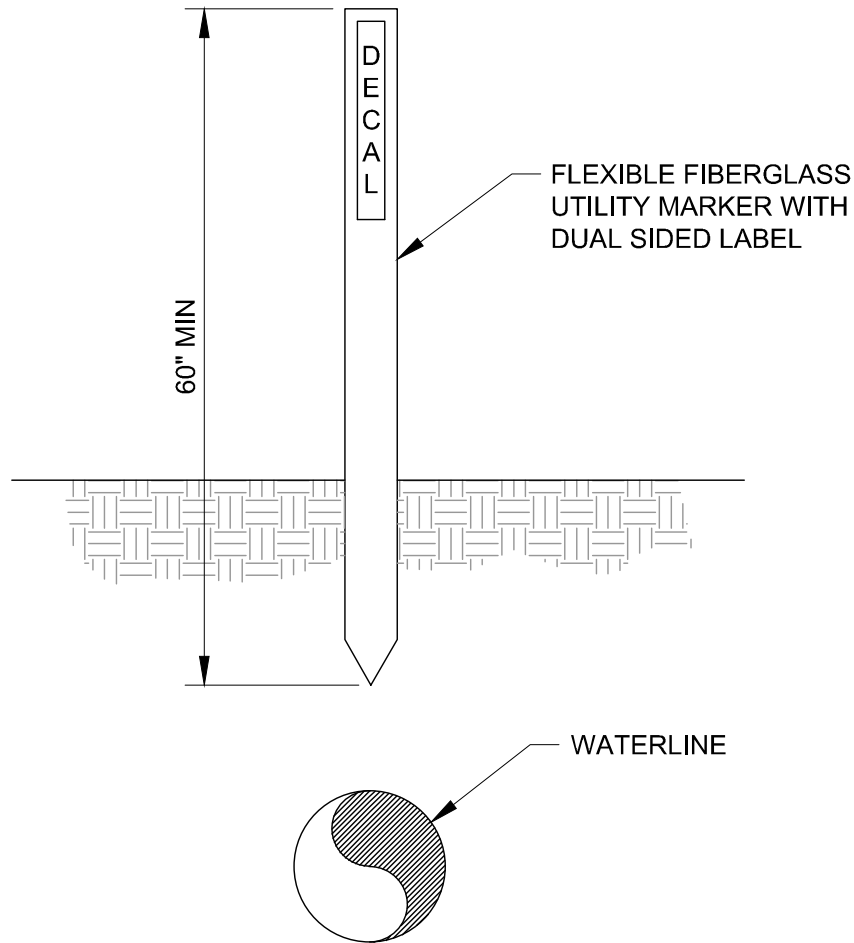

NOTES:

1. INSTALL REFERENCE POST WHEN WATERLINE IS LOCATED OUTSIDE OF PUBLIC RIGHT-OF-WAYS WHEN DIRECTED BY CITY ENGINEER AND WATER DEPARTMENT.
2. BURIED WATER LINE MARKER SHALL BE CONSTRUCTED ON 4" RHINO 3-RAIL FIBERGLASS UTILITY MARKER POSTS WITH VERBIAGE AS SHOWN ON THIS DETAIL. BY "RHINO" OR EQUAL. (WWW.RHINOMARKERS.COM)
3. PARK CITY LOGO IS WHITE PMS CL GY, 5CCV, 282CV AND 180CV. ALL TEXT AND GRAPHICS SHALL BE SET AGAINST A WHITE BACKGROUND. (RHINO MARKERS SHALL REFER TO SD-7964K DECAL)
4. MOUNT MARKERS PER MANUFACTURERS RECOMMENDATIONS.
5. INSTALL MARKERS AT LOCATIONS INDICATED ON PLANS BUT TYPICALLY EVERY 500 FT AND AT VALVES, TRACER WIRE BOXES, AND BENDS IN ALIGNMENT.
6. PLACE MARKER ON PIPE CENTERLINE.
7. OBTAIN LOGOS FROM PARK CITY TO PROVIDE TO SIGN MANUFACTURER.
8. PRINTING MATERIAL AND SIGN MATERIAL SHALL BE WATER-RESISTANT.
9. LABEL TO READ "CAUTION WATER PIPELINE - BEFORE DIGGING CALL 811"

 PARK CITY MUNICIPAL CORPORATION WATER	DATE	WATER LINE REFERENCE MARKER	STD. PLAN
	3/2014		596
	REV.		
	0		

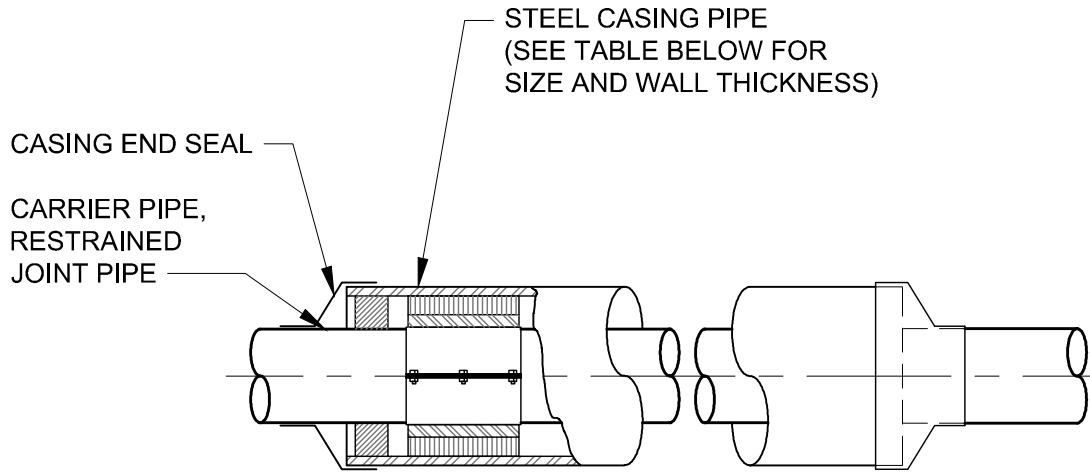

SLED

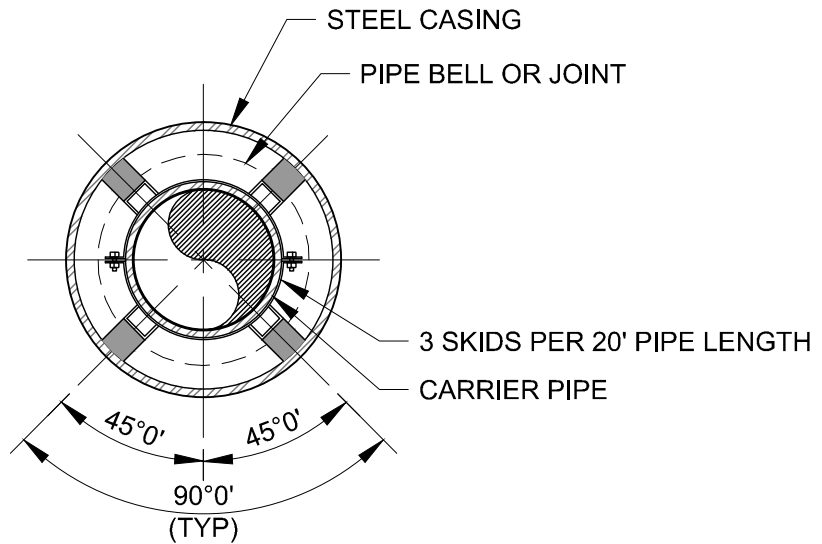

PIPE CASING

CARRIER PIPE NOMINAL DIAMETER	CASING PIPE	
	MIN OD	MIN WALL THICKNESS
4"	12"	0.25"
6"	16"	0.3125"
8"	18"	0.3125"
12"	22"	0.375"
16"	28"	0.50"
20"	32"	0.50"



PARK CITY MUNICIPAL CORPORATION
WATER

DATE

4/2014

REV.

0

WATERLINE CASING

STD. PLAN

597

LEGEND AND APPROVED PARTS LIST

ITEM	DESCRIPTION	ACCEPTABLE MANUFACTURER	MODELS
①	CASING END SEAL	PIPELINE SEAL AND INSULATOR, INC	MODEL "S"
②	CASING SPACER	PIPELINE SEAL AND INSULATOR, INC.	C12G-2 OR APPROVED EQUAL
③	CARRIER PIPE: DUCTILE IRON RESTRAINED JOINT (STD. PLAN 540)		

DETAIL NOTES

1. PROVIDE CARRIER AND CASING SIZE, LOCATION, AND DEPTH PER APPROVED PLANS
2. INSTALL MECHANICAL JOINT A MAXIMUM OF 18" FROM EACH END OF CASING
3. IF REQUIRED BY APPROVED PLANS, INSTALL CLOSED CELL INSULATION IN ANNULAR SPACE BETWEEN CARRIER PIPE AND CASING. INSTALLATION METHOD TO BE APPROVED BY CITY.

 PARK CITY MUNICIPAL CORPORATION WATER	DATE	WATERLINE CASING	STD. PLAN
	4/2014		597 S
	REV.		