

**PARK CITY MUNICIPAL CORPORATION  
PLANNING COMMISSION  
CITY COUNCIL CHAMBERS  
October 10, 2018**



**AGENDA**

**MEETING CALLED TO ORDER AT 5:30PM**

**ROLL CALL**

**ADOPTION OF MINUTES OF September 26, 2018**

**PUBLIC COMMUNICATIONS – Items not scheduled on the regular agenda**

**STAFF AND BOARD COMMUNICATIONS AND DISCLOSURES**

**REGULAR AGENDA – Discussion, public hearing, and possible action as outlined below**

LMC Amendments – LMC Amendments regarding Food Truck Locations. <i>Public Hearing and possible recommendation to City Council for October 23.</i>	PL-18-03846 <i>Planner Tyler</i>	24
PL-16-03412 – 638 Park Ave Remand – City Council Remand of a Conditional Use Permit (CUP) for a Private Event Facility Back to Planning Commission for Additional Review. <i>Public Hearing and possible action.</i>	PL-16-03412 <i>Planner Grahn</i>	64

**ADJOURN**

**\*Parking validations will be provided for Planning Commission meeting attendees that park in the China Bridge parking structure.**

A majority of Planning Commission members may meet socially after the meeting. If so, the location will be announced by the Chair person. City business will not be conducted.

Pursuant to the Americans with Disabilities Act, individuals needing special accommodations during the meeting should notify the Park City Planning Department at (435) 615-5060 24 hours prior to the meeting.



PARK CITY MUNICIPAL CORPORATION  
PLANNING COMMISSION MEETING MINUTES  
COUNCIL CHAMBERS  
MARSAC MUNICIPAL BUILDING  
September 26, 2018

COMMISSIONERS IN ATTENDANCE:

Chair Melissa Band, Sarah Hall, John Kenworthy, Mark Sletten, Laura Suesser, Doug Thimm

EX OFFICIO: Planning Director, Bruce Erickson; Kirsten Whetstone, Planner; Anya Grahn, Planner; Jody Burnett, Legal Counsel

=====

REGULAR MEETING

**ROLL CALL**

Chair Band called the meeting to order at 5:35 p.m. and noted that all Commissioners were present except Commissioner Phillips.

**ADOPTION OF MINUTES**

August 22, 2018

MOTION: Commissioner Thimm moved to APPROVE the Minutes of August 22, 2018 as written. Commissioner Suesser seconded the motion.

VOTE: The motion passed unanimously.

**PUBLIC COMMUNICATIONS**

There were no comments.

**STAFF/COMMISSIONER COMMUNICATIONS AND DISCLOSURES**

Planning Director Bruce Erickson reported that currently the Planning Commission was schedule to only have one meeting in November and December. The Staff was contemplating only one meeting in January due to Sundance. The meetings dates would most likely be scheduled at the beginning of the month to avoid Thanksgiving, Christmas, and New Year.

Chair Band asked if the agendas would be heavier than they have been. Director Erickson replied that the Staff thought the agendas would be heavier with Land Management Code changes. However, in discussions with the Legal Department regarding enforceability, the recommendation was to move some of the enforcement into the Business License Code rather than the LMC. Director Erickson explained that the LMC addresses the property

owner and the business license deals with the operator. On items that have significant operating issues, it might be better to enforce those under the business license. Planners Morlan and Tyler have been looking at the two Codes as they move forward.

Director Erickson anticipated that on October 10<sup>th</sup> the Planning Commission would be discussing the Kimball project that the City Council had remanded back to them.

Commissioner Kenworthy updated the Planning Commission on the Transportation Committee. The committee met last week and Nelson/Nygaard, the hired consultants, are in the process of gathering data. They have a survey that drills down on commuter and other issues. The survey was set for October but the committee would like them to push it to November because that month is a better baseline to conduct the survey. Commissioner Kenworthy stated that he was impressed with the diversity of the community on the committee. He was also impressed to see Doug Smith, the Wasatch County Planning Commissioner, at the meeting. Commissioner Kenworthy was pleased to hear that the Mayflower Development has proposed transit centers between Wasatch and Summit Counties. He believed this was a big step and he hoped they would be able to inch further into Heber Valley as they move forward.

Commissioner Sletten noted that Director Erickson had previously asked if he would also like to be on the Transportation Committee. He had not followed up with Director Erickson, but he was interested if they needed extra representation.

Director Erickson thought the Planning Commission needed a resolution to formally appoint Commissioners Kenworthy and Sletten to the Transportation Committee. Currently, they were operating in an ex-officio role.

Commissioner Sletten disclosed that he owns property in the sister subdivision to Moon Shadow. He did not believe that would affect his decision on the Moon Shadow item on the agenda this evening.

### **CONTINUATIONS (Public Hearing and Continue to date specified)**

Municipal Code Amendments regarding Recreational Vehicle Parking in Title 9: Parking Code (Chapters 9-1 and 9-2), Title 11: Buildings and Building Regulations (Chapter 11-15), and Title 15: Land Management Code (Chapters 15-3, 15-5, and 15-15).  
(Application PL-18-03479)

Chair Band opened the public hearing. There were no comments. Chair Band closed the public hearing.

MOTION: Commissioner Sletten moved to CONTINUE the Municipal Code Amendment to a date uncertain. Commissioner Kenworthy seconded the motion

VOTE: The motion passed unanimously.

Director Erickson reported that the Municipal Code Amendment was scheduled as a Work Session item on the City Council agenda for October 11, 2018. The City Council will provide direction before it comes back to the Planning Commission.

The Planning Commissioner moved into Work Session to discuss Code Enforcement

### **WORK SESSION – Citywide Strategic Code Enforcement**

Dave Thacker, the Chief Building Official, presented a Code Enforcement Update to the Planning Commission on community outreach, education, construction mitigation and conditions of approval as the focal point of all enforcement activity.

Mr. Thacker noted that previous updates were given to the City Council and some of the information had moved through various lines to the Planning Commission. Mr. Thacker thought this was a good opportunity to talk to the Planning Commission about some of the Code Enforcement efforts, as well as new pieces of enforcement. He also intended to provide an overview of Code Enforcement in general city-wide. Mr. Thacker stated that they were looking at a three-department member Code Enforcement Group. In addition, several groups throughout the City enforce codes and they all collaborate and work together.

Mr. Thacker emphasized that the objective this evening was a general overview of Code Enforcement. No specific projects or conditions were part of the presentation.

Mr. Thacker stated that the previous Code Enforcement updates discussed the hybrid style of enforcement. They do reactive enforcement as complaints are received. They also do proactive enforcement where site visits occur during construction and/or when they see a violation in other areas of the City. When violations are observed, people are notified of the violation and that they must rectify the situation.

Mr. Thacker stated that the process is to first educate. A City Council priority is to make sure that the public is aware that they are in violation. In some cases, people are aware they are in violation and choose to do so anyway. Code Enforcement does its best to work with people and then work through the process for enforcement. The current process is to educate and inform them of the violation. If the violation is not rectified, a

verbal or written warning notice is issued. If the violation is still not corrected, it moves to a citation process. A civil citation would be through an ACE program that Michele Downard established a few years ago. A criminal citation would be through the Police Department.

Commissioner Suesser wanted to know the third department that works on Code Enforcement besides the Building Department and Police Department. Mr. Thacker stated that as they work through the updates, they were trying to gather as much feedback as possible from the Planning Commission based on comments they hear from the community, and others. It is not a perfect process but they have made improvements and they continue to improve. All feedback aids in the continual improvement process.

Mr. Thacker stated that other updates specifically related to the Planning Commission and more specific to the Code Enforcement Group are conditions of approval and construction mitigation plans. City-wide they continue to enhance already great customer service, ensuring that they can give the customers what they need and make sure they understand it.

Mr. Thacker stated that the Code Enforcement City-wide groups consist of Police, Parking, Environmental Enforcement, Fire Marshall and Fire Code Officials, the Building Team, the Engineering Team, and Planning Team. There are others, but these seven groups do the most outward enforcement and can be considered city-wide Code Enforcement.

Mr. Thacker provided a breakdown of what each department addresses related to Code Enforcement. Police is noise, traffic, parking, public nuisance. The police Departments does a lot of after-hours Code Enforcement. The Building Department addresses construction mitigation plans, road closures, etc. Parking is parking violation for both construction and non-construction parking on City streets. The Engineering Department does a lot of right-of-way, construction of utilities, road cuts, infrastructure, etc. Environmental is the soils. The Planning Department has a gamut from landscaping to historic, conditions of approval, etc. Fire enforces the Fire Code piece which is prevention events, investigations, and wildland fires, etc.

Mr. Thacker stated that it was brought to his attention that something helpful moving forward would be to enhance the graphic to include phone numbers and first points of contact for these areas. He would email that information to the Planning Commission once it is compiled. After-hours contact information would also be included.

Mr. Thacker stated that the seven groups work together daily relative to the concerns and complaints received to achieve the best outcome in the enforcement process. They are working on consistency, so regardless of who is contacted, the person calling with a complaint will get the same process and the same answers. The goal is to continue learning and educating.

Mr. Thacker noted that a representative from every group was present this evening to answer questions.

Chair Band asked about the process and whether the contact information is on the website. She asked if whoever receives the call is responsible for sending the complaint to the correct departments. Mr. Thacker replied that currently the information was not available to the public. However, they were working on how to make sure the public knows where to go if they have a complaint. It would be a citizen portal where complaints can be reported online. The reported violation would then be funneled to the appropriate party based on the information given. The citizen can choose to either remain anonymous or agree to be contacted in the process. Mr. Thacker commented on another aspect that is currently on the website on the Code Enforcement page. Someone with a complaint or concern can fill out a sheet that goes to the Code Enforcement Staff in the Building Department. If they cannot directly address the complaint, they will pass it along to the proper party.

Mr. Thacker presented a generic beginning of a construction mitigation plan. He noted that every construction project that has a permit is required to have a construction mitigation plan. The software system is still in process and they were not yet ready to launch it. In the interim, there is a secondary process where customers can go to a link on the website and type in a permit number or address to pull up the construction mitigation plan and conditions of approval for a specific project. Mr. Thacker stated that people can also call the Building Department and request the construction mitigation plan. Mr. Thacker stated that another option discussed was some type of a QR Code on a sign in front of the building. They were still looking into ways to make that possible.

Commissioner Sletten stated that he had used the Backhoe Program and the main page where he could click on a site; however, there was a lot of information. He suggested a similar program that could be more user friendly in obtaining information. Mr. Thacker agreed. Once they implement the new software, it will be much easier to obtain the information.

Commissioner Suesser stated that the Planning Commission would like to see a clearer accountability by departments in the City in terms of enforcing conditions of approval.

Director Erickson explained that at the highest level, the Planning Department owns the lifespan of a land use project. Therefore, enforcement of the conditions of approval starts with the Planning Department. Director Erickson remarked that the main enforcement of conditions of approval start when an application is submitted for an action. The Staff reviews the entire previous history of the location in an effort to understand the action being taken. They see it a lot inside MPDs, Conditional Use Permits, and Subdivisions. The second level of enforcement are the conditions of approval that are not time stamped and do not require an annual review. The third level are conditions that are date stamped, which can include an annual review or three reported complaints. Director Erickson stated that there was very little tracking mechanism for the time sensitive conditions, and the Legal Department was trying to find a mechanism.

Mr. Thacker stated that in various jurisdictions, Code Enforcement is a primary topic but it never has a resolution. On the question of whether they would ever get it right, Mr. Thacker believed they would. However, the challenge with enforcement is that one party is pleased and the other party is frustrated.

Mr. Thacker stated that part of the process in making sure they get it right is ensuring that emotion is removed from the enforcement piece. They look at the facts and consider what is actually occurring and how it is affected by the Code; not by how it is affected by the other person involved. It takes a lot of patience on the part of the Code Enforcement Staff, and Park City is fortunate to have staff that can do it and do it well. Mr. Thacker emphasized that enforcement does not have a beginning or an end. It is continually ongoing and ever changing. They will continue to enhance the program and make it the best possible.

Commissioner Sletten commented on noise enforcement. If a citizen complains about noise, he wanted to know if the citizen has to accompany the officer or whether the officer goes by himself.

Sergeant Jay Randall with the Police Department believed the idea that the citizen has to accompany the officer stems from an incident that occurred many years ago. Having a citizen accompany is not part of the officers' training and it is never anticipated to occur. Sergeant Randall thought it would be an escalating technique. He explained that typically the officers separate all parties involved, take independent readings, and educate on both sides independently to come up with the best solution.

Commissioner Kenworthy stated that often times there are repeat offenders from the same home or commercial business for the noise ordinances. He wanted to know how

the Police Department tracks the number of complaints for the same address. Mr. Randall replied that law enforcement uses an operating system that assigns a case number to each complaint and the officer puts notes in each one. In addition to having a record of the complaint, they can also read the notes from the previous occurrence to find out who they spoke with, if action was taken, etc. It gives an officer the opportunity to track the complaint history of repeat offenders and determine whether it is necessary to move to the citation level. Commissioner Kenworthy asked if the officer is aware of the previous violations before going out with a sound meter. Sergeant Randall stated that most officers will ask if there is a history at that location. The Dispatcher will pull it up and provide dates and specific information. However, in some cases it might be different people holding a different event, and that can be an issue.

Director Erickson remarked that in a few situations the noise violation may or may not violate the noise ordinance itself, but there may be a special exception to the site or a condition of approval placed on a project. Currently, there is no easy way for the officers to find the conditions of approval inside a conditional use permit. Director Erickson stated that they were working on a mechanism to simplify the conditions of approval for items the police would enforce.

Chair Band agreed that the Planning Commission has placed conditions of approval with specifics for noise, parking, etc., that are contrary to a typical condition. She understood that at this point there was no reliable channel between the two. Director Erickson replied that Special Events is usually aware and they receive most of the phone calls. Noise is controlled by number of events per year, notification to the Police Dispatch, and police sign off on the special exceptions from the noise ordinance. The police also sign off on special events. Currently, there is no other mechanism.

Using nightly rentals as an example, Chair Band commented on conditional use permits that require a one-year review by the Planning Commission to make sure the conditions of approval are met. She wanted to know if there is a way to ensure that it comes back to the Planning Department in situations other than events. Director Erickson replied that this was one reason why they were making the conversion to the Business License. A rental operator would be more liable than the person who owns a house and lives out-of-state. Director Erickson stated that the City was still trying to find a mechanism to regulate parking without a parking permit program. Additional enforcement will be placed on the Parking Department with the new parking program.

Commissioner Kenworthy asked Mr. Thacker how the Building Department tracks a contractor who repeats the same violation at different job sites. He thought the majority of violations come from repeat offenders rather than one person who makes a mistake. Mr. Thacker stated that what the Building Department is able to enforce is specific to a

violation and not specific to an individual. If they receive a complaint for one address, they create a case, put it in the data base, and it is stored forever. If the same violation is committed months later, they will be able to track it, but they are not able to tag a violation to an individual. They have to enforce the violation itself. Mr. Thacker emphasized that the process is tied to an address and not an individual.

Commissioner Kenworthy remarked that it goes back to enforcement of the property and the property owner. If the property owner persuades the contractor to work beyond the designated stop time, the contractor is the one responsible for the violation. Issuing a Stop Work Order delays the project, but the delay affects the neighborhood and the people who complained.

Mr. Thacker stated that the Building Department uses a Stop Work Order as a tool to gain compliance; however, he agreed that it does delay the project. Depending on how the contract is set up, a delay may or may not affect the contractor. Mr. Thacker recognized that it was not a perfect process. The State regulates contractor licenses, but the City has the ability to work with the State if there are multiple violations with a specific contractor. In the past they have taken that step and worked with the State.

Chair Band asked if the City was prohibited from penalizing a contractor who continually repeats the same violation. Mr. Thacker replied that they do not have the right tools to do that. He explained that the State of Utah licenses the contractors and the City cannot take action against the license.

Commissioner Thimm stated that if a member of the public sees a project being built and has a question, he asked if that person would have a way to access the conditions of approval or the construction mitigation plan. Director Erickson replied that there was a current process, but it was difficult. He and Mr. Thacker were trying to develop a simplified process where someone could enter either the project number off the building permit or enter the address to find the conditions of approval and the construction management plan. Director Erickson was unsure whether the information would be available permanently or whether it would be dropped after a certain time period. Commissioner Thimm remarked that if the conditions of approval last for the lifetime of the project, he recommended that they be accessible permanently.

Commissioner Suesser wanted to know the oversight and supervision of renovating a historic structure. Planner Anya Grahn replied that the process is very intense. Once the owner receives project approval and obtains a building permit, the Planning Staff usually walks by at least once a week. The Staff tries to meet with the contractors and the construction team for a pre-construction meeting where they go over the expectations of the Planning Department, the Building Department, and Code

Enforcement to make sure they all have the same understanding. The building inspectors drive around and it is not uncommon for them to come to the Planning Department asking if something they observed was actually approved. Planner Grahn stated that all eyes are on the project while it is under construction.

Director Erickson stated that under the terms of the Historic District Design Review and when the HPB conducts their review, Landmark Structures require the Historic Preservation Planner to go onsite and approve the removal of historic materials one at a time and determine whether some of the materials can be salvaged. When the structure is reassembled, the Planners go back to the site to make sure it is reassembled properly. Director Erickson remarked that the Historic Preservation Team is very thorough.

The Planning Commission adjourned the Work Session and returned to the Regular Meeting.

#### **REGULAR AGENDA - DISCUSSION/PUBLIC HEARINGS/ POSSIBLE ACTION**

1. **1406 Park Avenue – Proposal to create a legal lot of record from a meets and bounds parcel measuring 3,557 square feet. (Application PL-18-03947)**

Planner Grahn noted that 1406 Park Avenue was a current metes and bounds parcel. The applicant was proposing to go through the plat amendment process in order to create a legal lot of record. A Historic District Design Review application was already approved for this project; however, a condition of approval requires the plat to be recorded prior to issuance of any building permits.

The Staff recommended that the Planning Commission forward a positive recommendation to the City Council based on the Findings of Fact, Conclusions of Law, and Conditions of Approval.

Chair Band opened the public hearing.

There were no comments.

Chair Band closed the public hearing.

MOTION: Commissioner Thimm moved to forward a POSITIVE recommendation to the City Council for the 1406 Park Avenue Plat Amendment located at the same address,

based on the Findings of Fact, Conclusions of Law, and Conditions of Approval as found in the draft ordinance. Commissioner Hall seconded the motion.

VOTE: The motion passed unanimously.

#### Findings of Fact – 1406 Park Avenue

1. The property is located at 1406 Park Avenue.
2. The site is not designated as historic on the City's Historic Sites Inventory.
3. On July 26, 2018, the applicant submitted a plat amendment application to the Planning Department to combine the existing metes and bounds parcel into a single lot of record measuring 3,557 square feet. It is Summit County Parcel SA-236.
4. The plat amendment application was complete on July 26, 2018.
5. There are several encroachments on this site. There is a wood fence that wraps the west (front), north (side) east (rear), and south (side) property lines; the fence encroaches over the west, north, and east property lines.
6. The existing house was constructed in 1912 and significantly altered between 1949 and 1982; it does not comply with the required setbacks. The applicant has proposed to demolish this house in order to redevelop the site.
7. The minimum required lot size in the Historic Residential Medium-Density (HRM) zoning district is 1,875 square feet for a single family house and 3,750 square feet for a duplex. The proposed lot size is 3,557 square feet; it complies for a single family house but does not comply for a duplex.
8. In the HRM Zoning District, there is no maximum building footprint. Rather, any new development will need to comply with the required setbacks as outlined in LMC 15-2.4.
9. This property is surrounded by single and multi-family dwellings. There is not a consistent house size in this neighborhood due to the mix of housing developments.
10. The proposed lot at 1406 Park Avenue measuring 3,557 square feet is much smaller than the typical lot sizes in this neighborhood. The average lot size is 18,738.50 square feet overall for lots in the 1300-1500 blocks of Park Avenue within the HRM Zoning District. The largest lot is at the Woodside Park Subdivision at 1353 Park Avenue (20,752 sf) and the smallest was the single-family development at 1323 Park Avenue (2,178 sf).
11. The minimum required lot width in the HRM zoning district is 37.50 feet; the proposed lot complies at 51.42 feet in width.
12. The minimum required setbacks in the HRM zone are 15 feet front yard, 20 feet for front-facing garages; the existing house complies with a 22-foot front yard setback.
13. The minimum required rear yard setback is 10 feet; the existing house does not comply with a 4-foot rear yard setback.

14. The minimum required side yard setbacks are 5 feet; the existing house complies with a 6.4-foot north side yard setback, and does not comply with a 4.9-foot south side yard setback. This is an existing non-complying condition.
15. The maximum building height above existing grade in the HRM zoning district is 27 feet. The existing house complies with a height of 15.8 feet.
16. The plat amendment will not create any new non-complying conditions. All noncomplying conditions are currently in existence.
17. All findings within the Analysis section and the recitals above are incorporated herein as findings of fact.

#### Conclusions of Law – 1406 Park Avenue

1. There is good cause for this Plat Amendment.
2. The Plat Amendment is consistent with the Park City Land Management Code and applicable State law regarding lot combinations.
3. Neither the public nor any person will be materially injured by the proposed Plat Amendment.
4. Approval of the Plat Amendment, subject to the conditions stated below, does not adversely affect the health, safety and welfare of the citizens of Park City.

#### Conditions of Approval – 1406 Park Avenue

1. The City Planner, City Attorney, and City Engineer will review and approve the final form and content of the plat for compliance with State law, the Land Management Code, and the conditions of approval, prior to recordation of the plat.
2. The applicant will record the plat at the County within one year from the date of City Council approval. If recordation has not occurred within one (1) years' time, this approval for the plat will be void, unless a request for an extension is made in writing prior to the expiration date and an extension is granted by the City Council.
3. Residential fire sprinklers will be required for all new construction per requirements of the Chief Building Official.
4. A 10-foot-wide public snow storage easement along the frontage of Park Avenue is required and shall be provided on the plat.
5. There is a wood fence that wraps the west (front), north (side) east (rear), and south (side) property lines; the fence encroaches over the west, north, and east property lines. The applicant shall either remove the fence or relocate the fence within his property lines prior to recording the plat amendment.
6. No building permit for any work that expands the footprint of the home, or would first require the approval of an HDDR, shall be granted until the plat amendment is recorded with the Summit County Recorder's office.

**2. 8945 Marsac Avenue – Moon Shadow Condominium plat for eight detached “PUD Style” units subject to the Flagstaff Development Agreement and Village at Empire Pass Master Planned Development.**  
**(Application PL-18-03848)**

Michael Demkowicz with Alliance Engineering introduced the applicant’s team; Kent Fossett with Alliance Engineering; Jeff Butterworth, Mark Enderlee, Mark Yarborough, and Rich Wagner with Storied Development.

Planner Whetstone reported that the applicant was requesting a recommendation to the City Council for a condominium plat. She explained that the Moon Shadow condominium plat consists of 8 PUD style units located off of a private street off Marsac Avenue within the development. The site is 6.77 acres. The condominium lots range in size from approximately half an acre to one acre. The property consists of both RD zoning and ROS zoning. All development must occur within the RD zone. The ROS portion is to the north and that area will require some forest management not related to construction of the units.

Planner Whetstone stated that the applicant was requesting a total of 31 unit equivalents. Each unit equivalent is 2000 square feet for a total of 62,000 square feet as the maximum to be identified on the plat. There were no requests for building height exceptions. The unit height would be within the 28 feet, plus an additional 5 feet if the pitched roof is at least 4:12. The applicant was requesting a front setback exception to keep the units closer to the private road, which also reduces the amount of disturbance in the back.

Planner Whetstone presented an aerial of the Flagstaff Development. She indicated the location of the Moon Shadow proposal on the north side of Marsac Avenue. She noted that Moon Shadow would be very similar to the Nakoma development further up Marsac. Planner Whetstone pointed out other developments in various pods in the Flagstaff Development.

Planner Whetstone reported that the property is subject to the Development Agreement for all of Flagstaff, which was amended in 2007, as well as the 15 Technical Reports, including the Construction Mitigation Plan Report that the Planning Commissioner recently amended. It is also subject to the Village at Empire Pass Master Planned Development for Pod A, as well as the plat notes for the Village at Empire Pass North Subdivision that was approved by the City Council a year ago. The subject lot is Lot 1 of that subdivision. Planner Whetstone noted that the conditions of approval would get transferred onto the plat when it is recorded.

Planner Whetstone explained that once the plat is approved and recorded, each unit is constructed. Once each unit is constructed, any supplemental condominium plat is brought to the Planning Commission and the City Council to be recorded to define the private area as everything with the building. There would be limited common area for decks and patios. The remaining area would be common area. Planner Whetstone stated that because each unit will be constructed individually, they would come back to the Planning Commission individually or possibly one or two at the same time. Once the plat is recorded, there will be a full accounting of the total square footage and all the unit equivalents.

Planner Whetstone explained the difference between PUD style units and single-family units. A single-family is one-unit equivalent with a 10,000 square foot maximum. A buried basement is not counted in the square footage. In a PUD style, every 2,000 square feet is a unit. For example, a 4,000 square foot unit would be 2 unit equivalents. The square footage includes all of the basement area but excludes 600 square feet of garage.

Planner Whetstone stated that there was no commercial density for this site, and no deed restricted affordable housing units. The remaining units for the on-mountain are located in the Lodge Buildings and the B2 East Building and still need to be built. Planner Whetstone noted that the applicant had agreed to dedicate easements within the open space area. There are existing trails as well as proposed trails. The dedicated easements would enable the City to make some good connection.

Planner Whetstone stated that the Staff had reviewed the proposed plat against the Village at Empire Pass MPD. The Master Plan identified this parcel for 19 townhouse units. The same 2,000 square feet density applies. However, this proposal is for eight PUD style units. The Planning Staff did an analysis to see if the proposal was in compliance and they determined that it does comply with the intent of the Master Plan. It is less density because the applicant was proposing 8 units rather than 19 units. The square footage ranges from 2500-5,000 square feet, depending on the units. Overall, the square footage is less than it would be with multi-family units. There is also less ground disturbance for the eight units. The applicant was proposing 4,000 square foot building pads; and the building footprint needs to fit within that 4,000 square feet.

Planner Whetstone noted that the skier bridge in the MPD was not being proposed for these eight units. There is only one entrance onto Marsac Avenue.

The Staff found that the proposed project was consistent with the approved Village at Empire Pass Master Planned Development, as well as the Village at Empire Pass North

Subdivision, and the amended Flagstaff Development Agreement. The Staff recommended that the Planning Commission conduct a public hearing and consider forwarding a positive recommendation to the City Council pursuant to the findings of fact, conclusions of law, and conditions of approval as outlined in the Staff report.

Michael Demkowicz presented images and exhibits. He commented on the annexation approval of 1999 and the MPD approval of 2004. He pointed out that the Code does not address PUD units. Therefore, the units would be PUD style but they were being reviewed as condominium units. Mr. Demkowicz noted that Nakoma and Moon Shadow were similar development and he provided a comparison to show the similarities.

Commissioner Suesser referred to the comparison and asked if a setback exception had been requested and granted in the Nakoma subdivision for the front setbacks. Planner Whetstone thought it was possible that a few might have a 20' setback to the garage instead of 25'. The Larkspur units also had the exception. If the slope is steeper, the LMC allows the Planning Commission to grant an exception to pull units closer to the street. Planner Whetstone could not recall whether that specifically occurred at Nakoma.

Mr. Demkowicz presented a slope map showing the areas in the RD zoning. He pointed out that most everything fits with the exception of a couple of units where the slope begins to drop off. He believed that giving everyone the same front yard exception would help bring unity to the development. The downhill side of the units was the primary reason for requesting the exception.

Director Erickson understood that the setback exception was off the private road and not off Marsac. Mr. Demkowicz replied that he was correct. He explained that the only access off Marsac is a driveway, which is defined as a private road. Planner Whetstone stated that it had been reviewed by the Fire District. The Fire District required 26' of asphalt. Planner Whetstone explained that they would have preferred a narrower width; however, the new Fire Code requires 30'. Therefore, there will be 26' of asphalt and 4' of curb and gutter.

Mr. Demkowicz presented cut sections of each unit to show that the 4,000 square foot building pad fits the site. It also shows that by pushing the units closer to the private road will minimize the amount of disturbance.

Chair Band approved of the driveway not going out on to the blind curve. She believed one entrance was a better design.

Chair Band opened the public hearing.

There were no comments.

Chair Band closed the public hearing.

Commissioner Thimm favored the setback reduction. The Planning Commission has denied similar requests in the past; however, he felt this request was for a good reason. Commissioner Thimm was pleased that they were maintaining 20' to the garage base because that allows a full car to be parked in the driveway. If changes are requested in the future, he would like the 20-feet to be maintained.

MOTION: Commissioner Sletten moved to forward a POSITIVE recommendation to the City Council for 8945 Marsac Avenue (Lot 1 Village at Empire Pass North Subdivision) Moon Shadow Condominium plat, based on the Findings of Fact, Conclusions of Law, and Conditions of Approval as found in the draft ordinance. Commissioner Kenworthy seconded the motion.

VOTE: The motion passed unanimously.

#### Findings of Fact – 8945 Marsac Avenue

1. Moon Shadow Condominiums plat for eight (8) units and a private cul-de-sac is located at 8945 Marsac Avenue on the 6.77 acre Lot 1 of the Village at Empire Pass North subdivision.
2. Lot 1 is located in the RD-MPD and ROS-MPD zoning districts.
3. The City Council approved the Flagstaff Mountain Development Agreement/Annexation Resolution 99-30 on June 24, 1999. The Agreement was amended in 2007. The Amended Agreement is the equivalent of a Large-Scale Master Plan and sets forth maximum densities, location of densities, and developer offered amenities, requirements and obligations.
4. The Amended Agreement specifies that a total of 87 acres, within three development pods (A, B1 and B2), of the 1,750 acres of annexation property may be developed for the Mountain Village. The Mountain Village is further constrained to a maximum density of 785 unit equivalents (UE) configured in no more than 550 dwelling units as multi-family, hotel, or PUD units, provided the number of PUD units does not exceed 60.
5. On July 28, 2004, the Planning Commission approved a Master Planned Development for the Village at Empire Pass that identified the area of this proposed plat for multi-family condominium units, subject to density limitations of the Amended

Flagstaff Development Agreement.

6. On June 15, 2017, the City Council approved the Village at Empire Pass North Subdivision creating four lots of record. Lot 1, the subject lot of this condominium plat, is 6.77 acres in area, and sufficient in size to cluster the proposed eight PUD style units accessing a private cul-de-sac.

7. Only RD zoned portions of the property are designated as private area and no units are allowed to be constructed in the ROS zoned portions.

8. The private cul-de-sac has access to Marsac Avenue (aka SR 224) and the applicant has obtained a conditional access permit and encroachment permit from UDOT for a secondary access for construction of the private street. The private cul-de-sac, to be known as Moon Shadow Court, is designed with the Fire District required total width of thirty feet (30') (roadway plus 24" roll gutters on both sides) as well as the required cul-de-sac diameter of ninety-six (96') feet.

9. No affordable housing units are required as part of this condominium plat. Final on-

mountain affordable housing obligations are to be incorporated into the remaining Village at Empire Pass MPD Lodge Buildings 1, 3 and 4, as well as future condominium buildings at B2 East Subdivision (Parcel B2 MPD Phase 2), as noted on the respective subdivision plats.

10. At the time of final construction and re-platting, all floor area including basement area and garage space greater than 600 square feet, will be counted towards the Unit Equivalents as allowed by the Flagstaff Development Agreement.

11. Applicant submitted Architectural Design Guidelines for the Moon Shadow Condominiums that reflect a unified architectural character, as well as consistency with the Empire Pass Design Guidelines.

12. The proposed pattern of development and this condominium plat are consistent with the approved Village at Empire Pass MPD and the Village at Empire Pass North Subdivision in terms of density, unit type, location and layout of units.

13. A total of 60 PUD style units are allowed within Pods A, B1 and B2 subject to the Amended Agreement. Fifty-two (52) PUD style units are currently platted and/or constructed within the Mountain Village in Pods A and B1. There are no PUD style units platted in Pod B2.

14. Up to thirty (31) Unit Equivalents (62,000 sf) are proposed to be divided between the eight (8) PUD style units, subject to all requirements of the 2007 Amended Flagstaff Development Agreement.

15. This parcel was identified as 19 multi-family attached units. While the MPD did not call out a specific density, multi-family townhouses have been approved with density ranging from 2,500 to 5,000 sf of floor area (Larkspur Townhouses in Pod A range from 3,250 sf to 3,450 sf per unit and average 3,350 sf). The 19 multi-family attached units of the concept plan would have resulted in between 47,500 sf to 95,000 sf of residential floor area (or 63,650 sf if each unit was on average 3,350 sf

similar to the nearby Larkspur units).

16. The proposed density (in terms of number of units, traffic, and general activity) is reduced from 19 to 8 units. The proposed density in terms of total square feet and UE (up to 62,000 sf (31 UE) is between the 47,500 sf and 95,000 sf that the 19 multi-family attached concept would have resulted in, had the units been between 2,500 sf and 5,000 sf. By comparison, nineteen (19) multi-family units at the 3,350 sf Larkspur average size would have resulted in a total of 63,650 sf (31.83 UE).

17. The proposed project results in one less road intersection with Marsac Avenue, less site grading due to the reduction of road and driveway areas and less than the floor area of the VEP MPD planned townhouse units. The net square footage of the proposed project is less than or consistent with the townhouses planned in the VEP MPD.

18. The PUD concept is similar to the Nakoma Condominium PUDs which are predominately second homes. The skier bridge is not part of this application and only one permanent entrance to Marsac has been approved by UDOT.

19. The proposed 8-unit PUD style plat is consistent with the approved VEP MPD, the Village at Empire Pass North subdivision and the Amended Flagstaff Development Agreement.

20. Two parking spaces are required for each unit.

21. Maximum Building Height in the RD District is 28' (33' allowed with a minimum 4:12 pitched roof).

22. Fifteen foot (15') front setbacks (20' to the front of the garage) are proposed to cluster units closer to the private street in order to decrease cut and fill, decrease driveway area, increase the separation from areas of 40% and greater slope, and to protect additional existing vegetation. Building pads are located a minimum of 10' from slopes 40% and greater, with the exception of topographic slope anomalies located on units A and D that are under the minimum threshold measurements of 25' rise and 50' run.

23. The MPD requires Construction Mitigation Plans to be submitted with each ACUP and building permit addressing all requirements of the Amended Agreement and Technical Reports.

24. Additional Recreational Trail Easements will be provided outside of those identified in the existing Flagstaff Development Agreement. Easements for both existing trails and a proposed new trail identified in Exhibit M of the Staff Report.

#### Conclusions of Law – 8945 Marsac Avenue

1. There is good cause for this condominium plat.
2. The condominium plat is consistent with the Amended Flagstaff Annexation and Development Agreement, the Village at Empire Pass North Subdivision, the Park City Land Management Code and applicable State laws regarding condominium

plats.

3. Neither the public nor any person will be materially injured by the proposed condominium plat.
4. Approval of the condominium plat, subject to the conditions stated below, does not adversely affect the health, safety and welfare of the citizens of Park City.

Conditions of Approval – 8945 Marsac Avenue

1. The City Attorney and City Engineer will review and approve the final form and content of the condominium plat for compliance with State law, Land Management Code, 2007 amended Flagstaff Development Agreement, the Village at Empire Pass MPD, and these conditions of approval, prior to recordation of the plat.
2. The applicant will record the condominium plat at the County within one year from the date of City Council approval. If recordation has not occurred within one year's time, this approval for the plat will be void unless an extension is requested prior to expiration and is granted by the City Council.
3. City Engineer and SBWRD approval of the final infrastructure and utility plans is a condition precedent to plat recordation.
4. A non-expired UDOT conditional access permit and encroachment permit shall be obtained prior to construction of the private road that accesses from Marsac Avenue (aka SR 224).
5. SBWRD shall be included in the Owner's Dedication.
6. Conditions of approval of the Village at Empire Pass MPD (Pod A) and the Village at Empire Pass North Subdivision plat continue to apply.
7. An administrative Conditional Use Permit for each of the eight dwellings is required prior to issuance of any building permits for the units. CUPs maybe combined.
8. All administrative Conditional Use Permit applications and approvals are subject to the Amended Development Agreement and Technical Reports as approved or amended.
9. The plat shall note that a declaration of condominium and a supplemental condominium plat for each unit shall be approved and recorded at Summit County prior to issuance of a certificate of occupancy. Supplemental plats may be combined.
10. The plat shall note that a Construction Mitigation Plan, including truck routing, is a submittal requirement for each administrative Conditional Use Permit and building permit.
11. The plat shall note that a final grading and utility plan, including storm water and drainage plans shall be submitted with each administrative Conditional Use Permit application. No building permits shall be issued until all necessary utility easements are recorded.
12. The plat shall note that approval by the Empire Pass Design Review Board is a

condition precedent to building permit issuance for each unit.

13. The plat shall note that a landscape plan, including provisions for water-efficient irrigation systems and drought tolerant plantings with limited turf, is a submittal requirement for each administrative CUP application and building permit. An arborist report, identifying trees and the general condition of trees located outside of the building pad that are proposed to be removed, is required to be submitted with the landscape plans. Final landscape plans, including plans to remove trees outside of the building pad, shall be approved by the Design Review Board prior to building permit issuance.

14. The plat shall note that a fire protection plan is a submittal requirement for each building permit and shall include fire protection in the form of residential sprinklers and landscaping that complies with Urban Wildland Interface requirements of the Park City Building Department at the time of building permit issuance.

15. The plat shall note that fire sprinklers will be required for new construction on the lots per the Chief Building Official at the time of review of building permits.

16. The plat shall note that at the time of final construction and re-platting with supplemental condominium plats, all floor area including basement area and any garage space greater than 600 square feet will be counted towards the Unit Equivalents as allowed by the Flagstaff Development Agreement.

17. The plat shall note that a maximum of 31 Unit Equivalents of residential density may be utilized for the eight units and each unit shall not exceed 7,750 total square feet, including all floor area, include all basement areas and excluding 600 square feet of garage area.

18. The plat shall note that no more than eight residential PUD style units are allowed on this property.

19. The plat shall note that no commercial density is allocated to this property with this plat.

20. The plat shall note that at the time of plat recordation, Moon Shadow Condominiums includes land within the RD Zone and additional lands within the ROS Zone. The ROS zoning line shall be indicated on plans submitted with the administrative conditional use permit applications. All construction of units shall be restricted to the RD zoned portion. Construction disturbances within ROS portions are subject to the Amended Development Agreement and associated Technical Reports.

21. The plat shall note that setback exceptions allow a minimum front setback of 15' with a minimum front setback to a front facing garage of 20'. All other LMC setbacks, setback exceptions and building height requirements of the RD Zone apply.

22. A financial guarantee, in a form and amount acceptable to the City and in conformance with these conditions of approvals, for the value of all required public and private improvements, shall be provided to the City prior to plat recordation. All public and private improvements shall be completed according to City standards

prior to release of this guarantee. Ten percent of the guarantee shall be held by the City for the warranty period and until such improvements are accepted by the City.

23. All required easements for trails will be provided prior to plat recordation.

24. A ten foot (10') wide snow storage easement shall be dedicated to the Empire Pass Master Owners Association along the street frontage of the lots.

25. All existing and required easements, based on review by the City Engineer, Department of Public Utilities and SBWRD will be shown on the plat prior to recordation, including utilities, storm drainage, access (public, utility and emergency), and snow storage.

26. The plat shall note that utility structures such as ground sleeves and transformers and other dry utility boxes must be located on the lots.

27. The plat shall note that this development is part of a common plan development and an MS4 storm water permit is required for all land disturbance activities, prior to building permit issuance.

28. The plat shall note that public safety access and public utility easements are hereby dedicated for all public and private streets.

29. The plat shall note that trees, structures and retaining walls shall not be located within SBWRD easements.

30. A plat note shall state that all Units will require privately owned and operated wastewater ejector pumps for wastewater service.

31. The plat shall note that the private street shall be owned, operated, maintained and repaired by the Master Association for the use and benefit of the owners of property in Empire Pass at Deer Valley in accordance with the Master Declaration.

32. The plat shall note that prior to building permit issuance, documentation from UDOT showing a valid, non-expired approval of access to Lot 1 off Marsac Avenue is required. Approval of the location of permanent access shall also be approved by the City Engineer.

33. Additional Recreational Trail Easements will be dedicated outside of those identified in the existing Flagstaff Development Agreement. Easements for both existing trails and a proposed new trail, as identified in Exhibit M of the Staff Report, will be identified on the plat prior to recordation and a plat note shall indicate that once constructed and or re-constructed these public trails will be considered to be within a fifteen-foot public trail easement.

34. Moon Shadow Court (a private street) shall also be dedicated as "Public Utility Access for purposes of operation and maintenance.

35. There shall be 30' wide public utility easements dedicated as Park City Water Service District easements for the purpose of operating, maintaining, repairing, eventual replacement and upgrade of one or more underground pipelines and appurtenances for conveyance, distribution, and/or transmission of water. The exact location of these easements shall be approved by the City Engineer prior to recordation of the plat.

36. The Building Pad shall be considered the Limits of Disturbance for each condominium unit. Forest health restoration and landscaping consistent with the Arborist reports and visual analysis would be considered similar to the Red Cloud Subdivision that allows an additional disturbance area within 20 feet of the building foundation. Driveways and utility installation would be exempt. No disturbance is allowed into the Limited Common ROS area.

The Park City Planning Commission Meeting adjourned at 6:35 p.m.

Approved by Planning Commission: \_\_\_\_\_

PENDING APPROVAL



# Planning Commission Staff Report

**Subject:** LMC Amendments – Food Truck Locations  
**Author:** Hannah M. Tyler, Planner II  
**Date:** October 10, 2018  
**Type of Item:** Legislative – LMC Amendment

### Summary Recommendation

The Planning Department requests the Planning Commission open a public hearing, review the proposed Land Management Code amendments regarding Food Truck Locations, and forward a positive recommendation to City Council.

### Description

**Project Name:** LMC Amendments regarding Food Truck Locations in Chapter 15-2.5-2 Uses in Historic Recreation Commercial (HRC) District, 15-2.6-2 Uses in Historic Commercial Business (HCB) District, 15-2.7-2 Uses in Recreation and Open Space (ROS) District, 15-2.13-2 Uses in Residential Development (RD) District, 15-2.14-2 Uses in Residential Development-Medium Density (RDM) District, 15-2.16-2 Uses in Recreation Commercial (RC) District, 15-2.17-2 Uses in Regional Commercial Overlay (RCO) District, 15-2.18-2 Uses in General Commercial (GC) District, 15-2.19-2 Uses in Light Industrial (LI) District, 15-2.22-2 Uses in Public Use Transition (PUT) District, 15-2.23-2 Uses in Community Transition (CT) District, and 15-15 Defined Terms.

**Applicant:** Planning Department  
**Proposal:** Revisions to the Land Management Code

### Reason for Review

Amendments to the Land Management Code (LMC) require Planning Commission recommendation and City Council adoption. City Council action may be appealed to a court of competent jurisdiction per Land Management Code (LMC) § 15-1-18.

### Background

Recent legislation resulted in changes to the State Code reducing local municipalities' ability to regulate Food Trucks. This legislation went into effect on May 8, 2018. Staff has proposed Amendments to the LMC to align with the new changes to the State Code regarding the location of Food Trucks. Below is a high level overview of the changes to the State Code:

- If a Restaurant is an Allowed/Conditional Use in a zone, Food Trucks cannot be prohibited in that zone.
- The use of public versus private property is a huge distinction, in that the City Council maintains full discretion on allowing an application to proceed on public property, even if underlying zoning allows Food Trucks. Licensed Food trucks on

private property that do not serve the public may operate at the discretion of the property owner. Property owners who want to establish a Food Truck Location that serves the public will need to obtain a Food Truck Location Administrative Permit issued by the Planning Director or his designee.

- Food Trucks at Special Events will be regulated through the Special Event process.

If a jurisdiction within the State of Utah has provided an annual inspection, staff cannot require an additional licensing inspection. As a result, staff retains no ability to regulate Food Trucks in accordance with the International Building and Fire Codes if the food truck is licensed by a different jurisdiction.

On May 3, 2018, Economic Development and Planning staff brought a [Staff Communication](#) to City Council regarding Food Truck Location regulations. On May 23, 2018, the Planning Commission continued the [Pending Ordinance \(pg. 29\)](#) pending policy direction from City Council.

On May 29, 2018, City staff coordinated a stakeholder outreach meeting with Historic Park City Alliance (HPCA), the Chamber of Commerce, the Restaurant Association, members of the real estate community, and representatives from Park City Mountain (PCM) and Deer Valley (DV). Broadly speaking, the stakeholder outreach group has the following input:

- Generally supportive of regulation of Food Truck Locations on Private and Public property.
- Generally interested in exploring possible location(s) for centralized Food Truck event(s) (temporary Food Truck park).
- See benefits of vehicular trip reductions through Food Truck operations at more remote events where goods and services are not immediately available (ex: Quinn's Sports Complex athletic events)
- Explore requirement of Temporary Tax Account to collect Restaurant Sales Tax. This can be done when a Food Truck is issued a Reciprocal Business License from the Finance Department.
- HPCA needs to discuss further with its membership before stating its position.

After the stakeholder outreach, staff conducted a Work Session with City Council on June 7, 2018 ([Staff Report](#) and [Draft Ordinance](#)). City Council gave staff policy direction to pursue to LMC Amendments as proposed and consider the following:

1. Find a central location for Food Trucks to be located (possibly on Public Property – outside of Right-of-Way) with preference to limit competition with local business including hours downtown that don't compete with dinner crowd.
2. Make the application process simple.

Since the June 7, 2018 City Council Work Session, staff has again reached out to the stakeholder group (HPCA, the Chamber of Commerce, the Restaurant Association, members of the real estate community, and representatives from PCM and DV) notifying them of the City Council policy direction and the proposed Ordinance. In

addition, on September 21, 2018 staff met with the Utah League of Cities and Towns (ULCT) to discuss the Ordinance.

### **Analysis**

Staff has continued to conduct additional research regarding Food Truck Location regulations since the City Council Work Session. Food Truck operations are not a new concept in the professional Land Use realm. In fact, many municipalities throughout the country have been regulating Food Truck operations for years.

The American Planning Association (APA), which is the national organization for planning and land use professionals, has issued a policy overview for "[Planning for Food Trucks](#)" which considers the strategies and challenges faced by jurisdictions. Below is an excerpt specifically addressing the challenges and competing interests when considering Food Truck regulations:

*"Despite the economic and social opportunities, food trucks still pose challenges for communities as they try to balance competing interests. Restaurateurs often claim that food trucks have an unfair advantage in the marketplace due to perceptions that mobile vendors pay less in taxes and are subject to less scrutiny from local regulators. This conflict is intensified by the fact that food trucks often operate in multiple locations—including areas that are not zoned for commercial uses—and can occupy valuable parking in areas of short supply. Local officials frequently struggle with questions of which agency should be principally in charge of regulating food trucks, how to handle permitting, and what restrictions should be placed on the vending units themselves."*

In addition, the National League of Cities published a [Report](#) which discusses the regulation and integration of Food Trucks into a community. The report speaks specifically to the stakeholder concerns of both the Food Truck community and the brick and mortar restaurant community as well as those of the Municipality attempting to regulate all entities fairly. Below is an excerpt from the report about the economic drivers for each stakeholder group:

*"For food trucks, one of the key objectives is to earn revenue. For brick and mortar restaurants, their goal is the same, and the level of competition food trucks create or are perceived to create can be of concern. For the community and city, creating opportunities for economic development is a key priority because it raises tax revenue, vibrancy, and creates a level of attractiveness for business and residents as well as for the city as a whole."*

This excerpt is exactly the conversation that staff posed to the May 29, 2018 stakeholder group and at the June 7, 2018 City Council Work Session. The City Council discussed opportunities for Food Trucks to operate on City Property and at City facilities as a means to provide a central location(s) for Food Trucks. It is understood that any Food Truck Location (Serving the public on Private Property) would have to comply with the underlying Zoning regulations (setbacks, sign regulations, etc.).

The facilitation of use of City-owned property is not the role of the Planning Department; however, the Economic Development Manager has taken the lead on exploring the limited use of City-owned property and City facilities for Food Truck Locations. On October 23, 2018, City Council will have a policy discussion related to a potential Request for Proposals (RFP) which would seek proposals for Food Trucks to use specific public spaces.

A concern raised by staff early in the process has been finding fairness in the taxation of the City's brick and mortar restaurants compared to Food Trucks that have an origin outside of City limits (ex: a Food Truck originating in Salt Lake City). Currently, the Utah State Code states that if a jurisdiction within the State of Utah has provided an annual inspection for a Food Truck, staff cannot require an additional inspection. However, Park City can and will require a Food Truck licensed in another jurisdiction to obtain a Reciprocal Business License from Park City Municipal Corporation. Planning staff has worked closely with the Finance Department to determine that the City can also require a Temporary Tax Account which will allow Park City to collect sales tax for transactions that take place within City Limits. This Temporary Tax Account will be established at the time of Reciprocal Business License issuance.

Title 4 of the Municipal Code is dedicated to Licensing (including Business Licensing). As a part of the Title 4 Licensing Code, staff has proposed additional language regarding Food Truck Location standards and reference to compliance with the underlying Zoning regulations (setbacks, sign regulations, etc.). In this section of the Municipal Code, staff will be regulating the site and location details of a Food Truck. A Food Truck will obtain a Business License for operation in any of the Zones that allow Food Truck Locations. Under UCA 11-56-106(5), the City cannot require a site plan for Food Trucks on private property if the Food Truck operates in the same location for less than 10 hours per week. The City Council will be reviewing the amendments to Title 4 on October 23, 2018 as changes to the Municipal Code are reviewed by City Council. Below is a high level overview of the standards applicable to the private property owner (not Food Trucks) that will be included in Title 4 of the Municipal Code:

- size and location of the Site
- Parking plan for the Food Truck, patrons, and employees
- emergency vehicle access
- pedestrian management plan
- signs and lighting
- noise, vibration, odors, steam, exhaust, or other mechanical factors that might affect people and Property Off-Site
- Screening of trash and recycling pickup Areas and location of restroom facilities
- Access to the location for the truck

Planning staff is proposing to amend the LMC to regulate Food Truck Locations as Allowed Uses in Zones where Restaurants are an Allowed or Conditional Use. In addition, staff has added the Recreation Open Space (ROS) District which currently does not allow Restaurants; however, Planning staff finds that Food Truck Locations would be consistent with the intent and [Purpose](#) of the ROS Zone. The Planning Director, or his designee shall, upon finding a Food Truck Location in compliance with

LMC Chapters 15-1-8 and 15-1-9, issue the property owner a Food Truck Location administrative approval letter. The following zones will be impacted by the proposed LMC Amendment:

- Historic Recreation Commercial (HRC)
- Historic Commercial Business (HCB)
- Residential Development (RD)
- Recreation Commercial (RC)
- Recreation Commercial Overlay (RCO)
- General Commercial (GC)
- Light Industrial (LI)
- Public Use Transition (PUT)
- Community Transition (CT)
- Recreation Open Space (ROS)

Staff has excluded the Historic Residential (HR-2) Zoning District where Restaurants are allowed only in Historic Structures because Food Trucks could not comply with this requirement (Food Trucks are not Historic Structures). Staff has also created a definition for Food Truck (Exhibit M).

The City is only proposing to regulate Food Truck Locations that are open to the general public, on private property, and in operation at that location for 10 hours a week or more. Food Trucks operating in the capacity of a “caterer”, meaning one (1) temporary point of sale for under 10 hours, would not be regulated; however, a Food Truck operating as a “caterer” would have to be located on private property.

### **General Plan**

Park City’s Economic Development Plan encourages facilitation and establishment of attractions and areas of interest for both visitors and residents, maintaining and improving the balance of Sustainable Community goals by going beyond economic initiatives to include social and environmental strategies, and protection and preservation of the historic Main Street downtown area as the heart of the region.

These proposed Land Management Code amendments were reviewed for consistency with the Park City General Plan. Park City General Plan Goal 11 states, “Support the continued success of the multi-seasonal tourism economy while preserving the community character that adds to the visitor experience,” and Objective 11A states, “The vibrancy of Park City’s resorts is essential to the success of resort support businesses. The City must provide flexibility to allow the primary resorts to evolve with the tourism industry, increase occupancy rates year round, and create more demand for the resort support industries throughout the City.”

### **Process**

Amendments to the Land Management Code require Planning Commission recommendation and City Council adoption. City Council action may be appealed to a court of competent jurisdiction per LMC § 15-1-18.

### **Department Review**

This report has been reviewed by the Legal Department and Community Development Department.

### **Notice**

Legal notice of a public hearing was posted in the required public spaces and public notice websites and published in the Park Record on September 26, 2018 per requirements of the Land Management Code.

### **Public Input**

Public hearings are required to be conducted by the Planning Commission and City Council prior to adoption of Land Management Code amendments.

### **Recommendation**

The Planning Department requests the Planning Commission open a public hearing, review the proposed Land Management Code amendments regarding Food Truck Locations, and forward a positive recommendation to City Council.

### **Exhibits**

#### Exhibit 1 LMC Draft Ordinance

- Exhibit A – LMC § 15-2.5-2 Uses in Historic Recreation Commercial (HRC) District
- Exhibit B – LMC § 15-2.6-2 Uses in Historic Commercial Business (HCB) District
- Exhibit C – LMC § 15-2.7-2 Uses in Recreation and Open Space (ROS) District
- Exhibit D – LMC § 15-2.13-2 Uses in Residential Development (RD) District
- Exhibit E – LMC § 15-2.14-2 Uses in Residential Development-Medium Density (RDM) District
- Exhibit F – LMC § 15-2.16-2 Uses in Recreation Commercial (RC) District
- Exhibit G – LMC § 15-2.17-2 Uses in Regional Commercial Overlay (RCO) District
- Exhibit H – LMC § 15-2.18-2 Uses in General Commercial (GC) District
- Exhibit I – LMC § 15-2.19-2 Uses in Light Industrial (LI) District
- Exhibit J – LMC § 15-2.22-2 Uses in Public Use Transition (PUT) District
- Exhibit K – LMC § 15-2.23-2 Uses in Community Transition (CT) District
- Exhibit L – LMC § 15-15 Defined Terms

**Exhibit 1 – Draft Ordinance**

**Ordinance No. 2018-XX**

**AN ORDINANCE REGULATING FOOD TRUCK LOCATIONS AND AMENDING THE LAND MANAGEMENT CODE OF PARK CITY, UTAH, AMENDING 15-2.5-2 USES IN HISTORIC RECREATION COMMERCIAL (HRC) DISTRICT; 15-2.6-2 USES IN HISTORIC COMMERCIAL BUSINESS (HCB) DISTRICT; 15-2.7-2 USES IN RECREATION AND OPEN SPACE (ROS) DISTRICT; 15-2.13-2 USES IN RESIDENTIAL DEVELOPMENT (RD) DISTRICT; 15-2.14-2 USES IN RESIDENTIAL DEVELOPMENT-MEDIUM DENSITY (RDM) DISTRICT; 15-2.16-2 USES IN RECREATION COMMERCIAL (RC) DISTRICT; 15-2.17-2 USES IN REGIONAL COMMERCIAL OVERLAY (RCO) DISTRICT; 15-2.18-2 USES IN GENERAL COMMERCIAL (GC) DISTRICT; 15-2.19-2 USES IN LIGHT INDUSTRIAL (LI) DISTRICT; 15-2.22-2 USES IN PUBLIC USE TRANSITION (PUT) DISTRICT; 15-2.23-2 USES IN COMMUNITY TRANSITION (CT) DISTRICT; AND 15-15 DEFINED TERMS.**

WHEREAS, the Land Management Code was adopted by the City Council of Park City, Utah, to promote the health, safety, and welfare of the residents, visitors, and property owners of Park City; and

WHEREAS, the Land Management Code implements the goals, objectives, and policies of the Park City General Plan to maintain the quality of life and experiences for its residents and visitors and to promote unique experiences for residents and visitors; and

WHEREAS, the City reviews the Land Management Code (LMC) on a regular basis and identifies necessary amendments to address planning and zoning issues; to address specific LMC issues raised by Staff, Planning Commission, and City Council; to align the Code with the Council's goals; and

WHEREAS, Utah Code 10-8-84 grants the City the right to pass ordinances that are necessary to provide for safety and health and to promote the prosperity of the City. Utah Code 10-9a-102 grants the City the right to pass such laws for the use of land; and

WHEREAS, Park City's Economic Development Plan encourages facilitation and establishment of attractions and areas of interest for both visitors and residents, maintaining and improving the balance of Sustainable Community goals by going beyond economic initiatives to include social and environmental strategies, and protection and preservation of the historic Main Street downtown area as the heart of the region; and

WHEREAS, Utah Code Section 11-56-103 preserves City authority:

- (a) requiring a food truck operator to comply with local zoning and land use regulations;
- (b) promulgating local ordinances and regulations consistent with Utah Code that

- address how and where a food truck may operate within the political subdivision;
- (c) requiring a food truck operator to obtain a special event permit, in accordance with Section 11-56-105; and
  - (d) revoking a license that the City has issued if the operation of the related food truck within the City violates the terms of the license.

WHEREAS, these proposed Land Management Code amendments were reviewed for consistency with the recently adopted Park City General Plan; and

WHEREAS, the proposed code changes address Park City General Plan Goal 11 which states, "Support the continued success of the multi-seasonal tourism economy while preserving the community character that adds to the visitor experience," and Objective 11A which states, "The vibrancy of Park City's resorts is essential to the success of resort support businesses. The City must provide flexibility to allow the primary resorts to evolve with the tourism industry, increase occupancy rates year round, and create more demand for the resort support industries throughout the City;" and

WHEREAS, the Planning Commission duly noticed and conducted public hearings at the regularly scheduled meeting on May 23, 2018 and October 10, 2018, and forwarded a \_\_\_\_\_ recommendation to City Council; and

WHEREAS, the City Council duly noticed and conducted a public hearing at its regularly scheduled meeting on October 23, 2018; and

WHEREAS, it is in the best interest of the residents and visitors of Park City, Utah, to amend the Land Management Code to be consistent with the values and goals of the Park City General Plan and the Park City Council and to protect health and safety and maintain the quality of life for its residents and visitors.

NOW, THEREFORE, BE IT ORDAINED by the City Council of Park City, Utah, as follows:

SECTION 1. APPROVAL OF AMENDMENTS TO TITLE 15 - Land Management Code Section 15-2.5-2 Uses in Historic Recreation Commercial (HRC) District. The recitals above are incorporated herein as findings of fact. Section 15-2.5-2 of the Land Management Code of Park City is hereby amended as redlined in Exhibit A.

SECTION 2. APPROVAL OF AMENDMENTS TO TITLE 15 - Land Management Code Section 15-2.6-2 Uses in Historic Commercial Business (HCB) District. The recitals above are incorporated herein as findings of fact. Section 15-2.6-2 of the Land Management Code of Park City is hereby amended as redlined in Exhibit B.

SECTION 3. APPROVAL OF AMENDMENTS TO TITLE 15 - Land Management Code Section 15-2.7-2 Uses in Recreation Open Space (ROS) District. The recitals

above are incorporated herein as findings of fact. Section 15-2.7-2 of the Land Management Code of Park City is hereby amended as redlined in Exhibit C.

SECTION 4. APPROVAL OF AMENDMENTS TO TITLE 15 - Land Management Code Section 15-2.13-2 Uses in Residential Development (RD) District. The recitals above are incorporated herein as findings of fact. Section 15-2.13-2 of the Land Management Code of Park City is hereby amended as redlined in Exhibit D.

SECTION 5. APPROVAL OF AMENDMENTS TO TITLE 15 - Land Management Code Section 15-2.14-2 Uses in Residential Development-Medium Density (RDM) District. The recitals above are incorporated herein as findings of fact. Section 15-2.14-2 of the Land Management Code of Park City is hereby amended as redlined in Exhibit E.

SECTION 6. APPROVAL OF AMENDMENTS TO TITLE 15 - Land Management Code Section 15-2.16-2 Uses in Recreation Commercial (RC) District. The recitals above are incorporated herein as findings of fact. Section 15-2.16-2 of the Land Management Code of Park City is hereby amended as redlined in Exhibit F.

SECTION 7. APPROVAL OF AMENDMENTS TO TITLE 15 - Land Management Code Section 15-2.17 Regional Commercial Overlay (RCO) District. The recitals above are incorporated herein as findings of fact. Section 15-2.17-2 of the Land Management Code of Park City is hereby amended as redlined in Exhibit G.

SECTION 8. APPROVAL OF AMENDMENTS TO TITLE 15 - Land Management Code Section 15-2.18-2 Uses in General Commercial (GC) District. The recitals above are incorporated herein as findings of fact. Section 15-2.18-2 of the Land Management Code of Park City is hereby amended as redlined in Exhibit H.

SECTION 9. APPROVAL OF AMENDMENTS TO TITLE 15 - Land Management Code Section 15-2.19-2 Uses in Light Industrial (LI) District. The recitals above are incorporated herein as findings of fact. Section 15-2.19-2 of the Land Management Code of Park City is hereby amended as redlined in Exhibit I.

SECTION 10. APPROVAL OF AMENDMENTS TO TITLE 15 - Land Management Code Section 15-2.22-2 Uses in Public Use Transition (PUT) District. The recitals above are incorporated herein as findings of fact. Section 15-2.22-2 of the Land Management Code of Park City is hereby amended as redlined in Exhibit J.

SECTION 11. APPROVAL OF AMENDMENTS TO TITLE 15 - Land Management Code Section 15-2.23-2 Uses in Community Transition (CT) District. The recitals above are incorporated herein as findings of fact. Section 15-2.23-2 of the Land Management Code of Park City is hereby amended as redlined in Exhibit K.

SECTION 12. APPROVAL OF AMENDMENTS TO TITLE 15 - Land Management Code Chapter 15-15 Defined Terms. The recitals above are incorporated

herein as findings of fact. Chapter 15-15 of the Land Management Code of Park City is hereby amended as redlined in Exhibit L.

SECTION 13. EFFECTIVE DATE. This Ordinance shall be effective upon publication.

PASSED AND ADOPTED this \_\_\_\_ day of \_\_\_\_\_, 2018

PARK CITY MUNICIPAL CORPORATION

\_\_\_\_\_  
Andy Beerman, Mayor

Attest:

\_\_\_\_\_  
City Recorder

Approved as to form:

\_\_\_\_\_  
Mark Harrington, City Attorney

**Exhibits**

- Exhibit A – LMC § 15-2.5-2 Uses in Historic Recreation Commercial (HRC) District
- Exhibit B – LMC § 15-2.6-2 Uses in Historic Commercial Business (HCB) District
- Exhibit C – LMC § 15-2.7-2 Uses in Recreation and Open Space (ROS) District
- Exhibit D – LMC § 15-2.13-2 Uses in Residential Development (RD) District
- Exhibit E – LMC § 15-2.14-2 Uses in Residential Development-Medium Density (RDM) District
- Exhibit F – LMC § 15-2.16-2 Uses in Recreation Commercial (RC) District
- Exhibit G – LMC § 15-2.17-2 Uses in Recreation Commercial Overlay (RCO) District
- Exhibit H – LMC § 15-2.18-2 Uses in General Commercial (GC) District
- Exhibit I – LMC § 15-2.19-2 Uses in Light Industrial (LI) District
- Exhibit J – LMC § 15-2.22-2 Uses in Public Use Transition (PUT) District
- Exhibit K – LMC § 15-2.23-2 Uses in Community Transition (CT) District
- Exhibit L – LMC § 15-15 Defined Terms

## Exhibit A – LMC § 15-2.5-2 Uses in Historic Recreation Commercial (HRC) District

### 15-2.5-2 USES IN HISTORIC RECREATION COMMERCIAL (HRC) DISTRICT

Uses in the HRC are limited to the following:

#### A. ALLOWED USES.<sup>10</sup>

1. Single Family Dwelling<sup>5</sup>
2. Duplex Dwelling<sup>5</sup>
3. Secondary Living Quarters<sup>5</sup>
4. Lockout Unit<sup>1,5</sup>
5. Accessory Apartment<sup>2,5</sup>
6. Nightly Rental<sup>5</sup>
7. Home Occupation<sup>5</sup>
8. Child Care, In-Home Babysitting
9. Child Care, Family<sup>3</sup>
10. Child Care, Family Group<sup>3</sup>
11. Child Care Center<sup>3</sup>
12. Accessory Building and Use
13. Conservation Activity
14. Agriculture
15. Bed and Breakfast Inn<sup>4,5</sup>
16. Boarding House, Hostel<sup>5</sup>
17. Hotel, Minor, fewer than 16 rooms<sup>5</sup>
18. Office, General<sup>5</sup>
19. Parking Area or Structure, with four (4) or fewer spaces<sup>5</sup>
20. Food Truck Location<sup>11</sup>

#### B. CONDITIONAL USES.<sup>9, 10</sup>

1. Triplex Dwelling<sup>5</sup>
2. Multi-Unit Dwelling<sup>5</sup>
3. Guest House, on Lots one acre<sup>5</sup>
4. Group Care Facility<sup>5</sup>
5. Public and Quasi-Public Institution, Church, School
6. Essential Municipal Public Utility Use, Facility, Service and Structure
7. Telecommunication Antenna<sup>6</sup>
8. Satellite Dish, greater than thirty-nine inches (39") in diameter<sup>7</sup>
9. Plant and Nursery stock products and sales
10. Hotel, Major<sup>5</sup>
11. Timeshare Projects and Conversions<sup>5</sup>
12. Private Residence Club Project and Conversion<sup>4,5</sup>
13. Office, Intensive<sup>5</sup>
14. Office and Clinic, Medical<sup>5</sup>
15. Financial Institution, without drive-up window<sup>8</sup>
16. Commercial Retail and Service, Minor<sup>8</sup>
17. Commercial Retail and Service, personal improvement<sup>8</sup>
18. Neighborhood Convenience Commercial, without gasoline sales

19. Café or Deli<sup>8</sup>
20. Restaurant, General<sup>8</sup>
21. Restaurant and café, Outdoor Dining<sup>4</sup>
22. Outdoor Events and Uses<sup>4</sup>
23. Bar
24. Parking Area or Structure, with five (5) or more spaces<sup>5</sup>
25. Temporary Improvement<sup>4</sup>
26. Passenger Tramway Station and Ski Base Facility
27. Ski Tow, Ski Lift, Ski Run, and Ski Bridge
28. Recreation Facility, Commercial, Public, and Private
29. Entertainment Facility, Indoor
30. Fences greater than six feet (6') in height from Final Grade<sup>4</sup>
31. Private Residence Club, Off-Site<sup>5</sup>
32. Private Event Facility<sup>5</sup>
33. Special Events<sup>4</sup>

C. **PROHIBITED USES.** Unless otherwise allowed herein, any Use not listed above as an Allowed or Conditional Use is a prohibited Use.

<sup>1</sup>Nightly rental of Lockout Units requires a Conditional Use permit

<sup>2</sup>See LMC Chapter 15-4, Supplementary Regulations for Accessory Apartments

<sup>3</sup>See LMC Chapter 15-4-9 for Child Care Regulations

<sup>4</sup>Requires an Administrative or Administrative Conditional Use permit, see Section 15-4.

<sup>5</sup>Prohibited in HRC Zoned Storefront Property adjacent to Main Street, Heber Avenue and Park Avenue, excluding those HRC Zoned Properties on the west side of Park Avenue and also excluding those HRC Zoned Properties with the following addresses: 702 Main Street, 710 Main Street, 738 Main Street (for the plaza side storefronts), 780 Main Street, 804 Main Street (for the plaza side storefronts), 875 Main Street, 890 Main Street, 900 Main Street, and 820 Park Avenue. Hotel rooms shall not be located within Storefront Property; however access, circulation, and lobby areas are permitted within Storefront Property.

<sup>6</sup>See LMC Chapter 15-4-14, Supplemental Regulations For Telecommunication Facilities

<sup>7</sup>See LMC Chapter 15-4-13, Supplemental Regulations For Satellite Receiving Antennas

<sup>8</sup>If Gross Floor Area is less than 2,000 sq. ft., the Use shall be considered an Allowed Use

<sup>9</sup>No community locations are defined by Utah Code 32-B-1-102 (Alcoholic Beverage Control Act) are permitted within 200 feet of Main Street unless a variance is permitted for an outlet, as defined by Utah Code 32B-1-202, to obtain a liquor license.

<sup>10</sup>Within the HRC Zoning District, no more than seven (7) Conventional Chain Businesses are permitted in Storefront Properties.

<sup>11</sup> The Planning Director, or his designee shall, upon finding a Food Truck Location in compliance with LMC Chapters 15-1-8 and 15-1-9, issue the property owner a Food Truck Location administrative approval letter.

*Adopted by Ord. 00-51 on 9/21/2000*

*Amended by Ord. 04-39 on 3/18/2004*

*Amended by Ord. 06-69 on 10/19/2006*

*Amended by Ord. 07-55 on 8/30/2007*

*Amended by Ord. 09-10 on 3/5/2009*

*Amended by Ord. 12-37 on 12/20/2012*  
*Amended by Ord. 16-02 on 1/7/2016*  
*Amended by Ord. 2017-45 on 8/17/201*

## Exhibit B – LMC § 15-2.6-2 Uses in Historic Commercial Business (HCB) District

### 15-2.6-2 USES IN HISTORIC COMMERCIAL BUSINESS (HCB) DISTRICT

Uses in the Historic Commercial Business (HCB) District are limited to the following:

#### A. ALLOWED USES.<sup>11</sup>

1. Single Family Dwelling<sup>1</sup>
2. Multi-Unit Dwelling<sup>1</sup>
3. Secondary Living Quarters<sup>1</sup>
4. Lockout Unit<sup>1,2</sup>
5. Accessory Apartment<sup>1,3</sup>
6. Nightly Rental<sup>4</sup>
7. Home Occupation<sup>1</sup>
8. Child Care, In-Home Babysitting<sup>1</sup>
9. Child Care, Family<sup>1,5</sup>
10. Child Care, Family Group<sup>1,5</sup>
11. Child Care Center<sup>1,5</sup>
12. Accessory Building and Use<sup>1</sup>
13. Conservation Activity
14. Agriculture
15. Bed and Breakfast Inn<sup>1,6</sup>
16. Boarding House, Hostel<sup>1</sup>
17. Hotel, Minor, fewer than 16 rooms<sup>1</sup>
18. Office, General<sup>1</sup>
19. Office, Moderate Intensive<sup>1</sup>
20. Office and Clinic, Medical<sup>1</sup>
21. Financial Institution, without drive-up window
22. Commercial Retail and Service, Minor
23. Commercial Retail and Service, personal improvement
24. Commercial Neighborhood Convenience, without gasoline sales
25. Restaurant, Cafe or Deli
26. Restaurant, General
27. Bar
28. Parking Lot, Public or Private with four (4) or fewer spaces
29. Entertainment Facility, Indoor
30. Salt Lake City 2002 Winter Olympic Games Legacy Displays<sup>7</sup>
31. Temporary Winter Balcony Enclosures
32. Food Truck Location<sup>12</sup>

#### B. CONDITIONAL USES.<sup>10, 11</sup>

1. Group Care Facility<sup>1</sup>
2. Public and Quasi-Public Institution, Church, School
3. Essential Municipal Public Utility Use, Facility, Service, and Structure
4. Telecommunication Antenna<sup>8</sup>
5. Satellite Dish, greater than thirty-nine inches (39") in diameter<sup>9</sup>
6. Plant and Nursery stock products and sales

7. Hotel, Major<sup>1</sup>
8. Timeshare Projects and Conversions<sup>1</sup>
9. Timeshare Sales Office, Off-Site within an enclosed Building<sup>1</sup>
10. Private Residence Club Project and Conversion<sup>1,6</sup>
11. Commercial Retail and Service, Major
12. Office, Intensive<sup>1</sup>
13. Restaurant, Outdoor Dining<sup>6</sup>
14. Outdoor Events and Uses<sup>6</sup>
15. Hospital, Limited Care Facility<sup>1</sup>
16. Parking Area or Structure for five (5) or more cars<sup>1</sup>
17. Temporary Improvement<sup>6</sup>
18. Passenger Tramway Station and Ski Base Facility
19. Ski Tow, Ski Lift, Ski Run, and Ski Bridge
20. Recreation Facility, Public or Private
21. Recreation Facility, Commercial
22. Fences greater than six feet (6') in height from Final Grade<sup>6</sup>
23. Private Residence Club, Off-Site<sup>1</sup>
24. Special Events<sup>6</sup>
25. Private Event Facility<sup>1</sup>

C. **PROHIBITED USES.** Any Use not listed above as an Allowed or Conditional Use is a prohibited Use.

<sup>1</sup>Prohibited in HCB Zoned Storefront Property adjacent to Main Street, Heber Avenue, Grant Avenue, and Swede Alley. Hotel rooms shall not be located within Storefront Property; however access, circulation and lobby areas are permitted within Storefront Property.

<sup>2</sup>Nightly Rental of Lock Units requires a Conditional Use permit

<sup>3</sup>See LMC Chapter 15-4, Supplementary Regulations for Accessory Apartments

<sup>4</sup>Nightly Rental of residential dwellings does not include the Use of dwellings for Commercial Uses

<sup>5</sup>See LMC Chapter 15-4-9 for Child Care Regulations

<sup>6</sup>Requires an Administrative or Administrative Conditional Use permit

<sup>7</sup>Olympic Legacy Displays limited to those specific Structures approved under the SLOC/Park City Municipal Corporation Olympic Services Agreement and/or Olympic Master Festival License and placed on the original Property set forth in the services Agreement and/or Master Festival License. Requires an Administrative Permit.

<sup>8</sup>See LMC Chapter 15-4-14, Supplemental Regulations for Telecommunication Facilities

<sup>9</sup>See LMC Chapter 15-4-13, Supplemental Regulations for Satellite Receiving Antennas

<sup>10</sup>No community locations as defined by Utah Code 32B-1-102 (Alcoholic Beverage Control Act) are permitted within 200 feet of Main Street unless a variance is permitted for an outlet, as defined by Utah Code 32B-1-202, to obtain a liquor license.

<sup>11</sup>Within the HCB Zoning District, no more than seventeen (17) Conventional Chain Businesses are permitted in Storefront Properties.

<sup>12</sup> The Planning Director, or his designee shall, upon finding a Food Truck Location in compliance with LMC Chapters 15-1-8 and 15-1-9, issue the property owner a Food Truck Location administrative approval letter.

*Adopted by Ord. 00-51 on 9/21/2000  
Amended by Ord. 02-38 on 9/12/2002  
Amended by Ord. 04-39 on 3/18/2004  
Amended by Ord. 06-69 on 10/19/2006  
Amended by Ord. 07-55 on 8/30/2007  
Amended by Ord. 09-10 on 3/5/2009  
Amended by Ord. 12-37 on 12/20/2012  
Amended by Ord. 16-01 on 1/7/2016  
Amended by Ord. 16-02 on 1/7/2016  
Amended by Ord. 2017-45 on 8/17/2017*

## Exhibit C – LMC § 15-2.7-2 Uses in Recreation and Open Space (ROS) District

### 15-2.7-2 Uses in Recreation and Open Space (ROS) District

Uses in the ROS District are limited to the following:

#### A. ALLOWED USES.

1. Conservation Activity
2. Food Truck Location<sup>4</sup>

#### B. ADMINISTRATIVE CONDITIONAL USES<sup>1</sup>.

1. Trail and Trailhead Improvement
2. Outdoor Recreation Equipment
3. Essential Municipal Public Utility Use, Service, or Structure, less than 600 sq. ft.
4. Accessory Building, less than 600 sq. ft.
5. Ski-related Accessory Building, less than 600 sq. ft.
6. Parking Area or Structure with four (4) or fewer spaces
7. Outdoor Event, Outdoor Music
8. Temporary Construction Improvement
9. Raising, grazing of horses
10. Raising, grazing of livestock
11. Anemometer and Anemometer Towers

#### C. CONDITIONAL USES.

1. Agriculture
2. Recreational Outdoor and Trail Lighting
3. Recreation Facility, Private
4. Recreation Facility, Public
5. Recreation Facility, Commercial
6. Golf Course
7. Passenger Tramway Station and Ski Base Facility
8. Ski Tow Rope, Ski Lift, Ski Run and Ski Bridge
9. Recreational Sports Field
10. Skating Rink
11. Skateboard Park
12. Public and Quasi-Public Institution, Church, and School, Park, Plaza, Structure for Public Assembly, greater than 600 sq. ft.
13. Essential Municipal Public Utility Use, Facility, Service, and Structure, greater than 600 sq. ft.
14. Accessory Building, greater than 600 sq. ft.
15. Ski-Related Accessory Building, greater than 600 sq. ft.
16. Child Care Center
17. Commercial Stable, Riding Academy
18. Vehicle Control Gates<sup>2</sup>
19. Resort Support, Commercial
20. Cemetery
21. Parking Area or Structure with five (5) or more spaces
22. Telecommunications Antenna<sup>3</sup>

- 23. Mines and Mine Exploration
- 24. Plant and Nursery stock products and sales
- 25. Fences greater than six feet (6') in height from Final Grade.
- 26. Small Wind Energy Systems

D. **PROHIBITED USES**. Any use not listed above as an Allowed or Conditional Use is a prohibited Use.

<sup>1</sup>Subject to an Administrative Conditional Use permit and/or Master Festival license review process. Master Festivals are temporary in nature. All related temporary Structures are restricted to specific time frames and shall be removed at the expiration of the Master Festival permit.

<sup>2</sup>See Section 15-4-19 for specific review criteria for gates

<sup>3</sup>Subject to LMC Chapter 15-4-14, Telecommunications

<sup>4</sup>The Planning Director, or his designee shall, upon finding a Food Truck Location in compliance with LMC Chapters 15-1-8 and 15-1-9, issue the property owner a Food Truck Location administrative approval letter.

*Adopted by Ord. 00-51 on 9/21/2000*

*Amended by Ord. 04-08 on 3/4/2004*

*Amended by Ord. 09-10 on 3/5/2009*

## Exhibit D – LMC § 15-2.13-2 Uses in Residential Development (RD) District

### 15-2.13-2 USES IN RESIDENTIAL DEVELOPMENT (RD) DISTRICT

Uses in the RD District are limited to the following:

#### A. ALLOWED USES.

1. Single-Family Dwelling
2. Duplex Dwelling
3. Secondary Living Quarters
4. Lockout Unit<sup>1</sup>
5. Accessory Apartment<sup>2</sup>
6. Nightly Rental<sup>3</sup>
7. Home Occupation
8. Child Care, In-Home Babysitting<sup>4</sup>
9. Child Care, Family<sup>4</sup>
10. Child Care, Family Group<sup>4</sup>
11. Accessory Building and Use
12. Conservation Activity Agriculture
13. Parking Area or Structure with four (4) or fewer spaces
14. Recreation Facility, Private
15. Salt Lake City 2002 Winter Olympic Games Olympic Legacy Displays<sup>5</sup>
16. Food Truck Location<sup>15</sup>

#### B. CONDITIONAL USES.

1. Triplex Dwelling<sup>6</sup>
2. Multi-Unit Dwelling<sup>6</sup>
3. Guest House
4. Group Care Facility
5. Child Care Center<sup>4</sup>
6. Public and Quasi-Public Institution, Church, and School
7. Essential Municipal Public Utility Use, Facility, Service, and Structure
8. Telecommunication Antenna<sup>7</sup>
9. Satellite Dish Antenna, greater than thirty-nine inches (39") in diameter<sup>8</sup>
10. Raising, grazing of horses
11. Cemetery
12. Bed and Breakfast Inn
13. Hotel, Minor<sup>6</sup>
14. Hotel, Major<sup>6</sup>
15. Private Residence Club Project and Conversion<sup>10</sup>
16. Office, General<sup>6,9</sup>
17. Office, Moderate Intensive<sup>6,9</sup>
18. Office, Medical<sup>6,9</sup>
19. Financial Institution without drive-up window<sup>6,9</sup>
20. Commercial Retail and Service, Minor<sup>6,9</sup>
21. Commercial Retail and Service, personal improvement<sup>6,9</sup>
22. Commercial, Resort Support<sup>6,9</sup>

23. Café or Deli<sup>6,9</sup>
24. Restaurant, Standard<sup>6,9</sup>
25. Restaurant, Outdoor Dining<sup>10</sup>
26. Outdoor Event<sup>10</sup>
27. Bar<sup>6,9</sup>
28. Hospital, Limited Care Facility<sup>6,9</sup>
29. Parking Area or Structure with five (5) or more spaces
30. Temporary Improvement<sup>10</sup>
31. Passenger Tramway Station and Ski Base Facility<sup>11</sup>
32. Ski Tow, Ski Lift, Ski Run, and Ski Bridge<sup>11</sup>
33. Recreation Facility, Public
34. Recreation Facility, Commercial<sup>6</sup>
35. Entertainment Facility, Indoor<sup>6,9</sup>
36. Commercial Stables, Riding Academy<sup>12</sup>
37. Master Planned Development with moderate income housing density bonus<sup>12</sup>
38. Master Planned Development with residential and transient lodging Uses only<sup>12</sup>
39. Master Planned Development with Support Retail and Minor Service Commercial Uses<sup>12</sup>
40. Heliport<sup>12</sup>
41. Vehicle Control Gate<sup>13</sup>
42. Fences and walls greater than six feet (6') in height from Final Grade<sup>10</sup>
43. Salt Lake City 2002 Winter Olympic Games Olympic Legacy Displays<sup>14</sup>
44. Amenities Club

C. **PROHIBITED USES.** Any Use not listed above as an Allowed or Conditional Use is a prohibited Use.

<sup>1</sup>Nightly rental of Lockout Units requires a Conditional Use permit

<sup>2</sup>See LMC Chapter 15-4-7, Supplemental Regulations for Accessory Apartments

<sup>3</sup>Nightly Rentals do not include the Use of dwellings for Commercial Uses and Nightly Rentals are not permitted in the April Mountain and Mellow Mountain Estates Subdivisions

<sup>4</sup>See LMC Chapter 15-4-9 for Child Care Regulations

<sup>5</sup>Olympic Legacy Displays limited to those specific Structures approved under the SLOC/Park City Municipal Corporation Olympic Services Agreement and/or Olympic Master Festival License and placed on the original Property set forth in the services agreement and/or Master Festival License.

<sup>6</sup>Subject to provisions of LMC Chapter 15-6, Master Planned Development

<sup>7</sup>See LMC Chapter 15-4-14, Supplemental Regulations for Telecommunications Facilities

<sup>8</sup>See LMC Chapter 15-4-13, Supplemental Regulations for Satellite Receiving Antennas

<sup>9</sup>Allowed only as a secondary or support Use to the primary Development or Use and intended as a convenience for residents or occupants of adjacent or adjoining residential Developments.

<sup>10</sup>Requires an administrative Conditional Use permit.

<sup>11</sup>As part of an approved Ski Area Master Plan. See LMC Chapter 15-4-18.

<sup>12</sup>Subject to provisions of LMC Chapter 15-6, Master Planned Development

<sup>13</sup>See Section 15-4-19 for specific review criteria for gates

<sup>14</sup>Olympic Legacy Displays limited to those specific Structures approved under the

SLOC/Park City Municipal Corporation Olympic Services Agreement and/or Olympic Master Festival License and placed in an Area other than the original location set forth in the services agreement and/or Master Festival License.

<sup>15</sup> The Planning Director, or his designee shall, upon finding a Food Truck Location in compliance with LMC Chapters 15-1-8 and 15-1-9, issue the property owner a Food Truck Location administrative approval letter.

*Adopted by Ord. 00-51 on 9/21/2000  
Amended by Ord. 02-38 on 9/12/2002  
Amended by Ord. 04-08 on 3/4/2004  
Amended by Ord. 05-39 on 6/30/2005  
Amended by Ord. 06-76 on 11/9/2006  
Amended by Ord. 11-05 on 1/27/2011  
Amended by Ord. 14-35 on 6/26/2014*

## **Exhibit E – LMC § 15-2.14-2 Uses in Residential Development-Medium Density (RDM) District**

### **15-2.14-2 USES IN RESIDENTIAL DEVELOPMENT-MEDIUM DENSITY (RDM) DISTRICT**

Uses in the RDM District are limited to the following:

#### **A. ALLOWED USES.**

1. Single Family Dwelling
2. Duplex Dwelling
3. Triplex Dwelling
4. Secondary Living Quarters
5. Lockout Unit<sup>1</sup>
6. Accessory Apartment<sup>2</sup>
7. Nightly Rental<sup>3</sup>
8. Home Occupation
9. Child Care, In Home Babysitting<sup>4</sup>
10. Child Care, Family<sup>4</sup>
11. Child Care, Family Group<sup>4</sup>
12. Accessory Building and Use
13. Conservation Activity
14. Agriculture
15. Parking Area or Structure with four (4) or fewer spaces
16. Recreation Facility, Private
17. Salt Lake City 2002 Winter Olympic Games Olympic Legacy Displays<sup>5</sup>
18. Food Truck Location<sup>14</sup>

#### **B. CONDITIONAL USES.**

1. Multi Unit Dwelling<sup>6</sup>
2. Guest House
3. Group Care Facility
4. Child Care Center
5. Public and Quasi Public Institution, Church, and School
6. Essential Municipal Public Utility Use, Facility, Service, and Structure
7. Telecommunication Antenna<sup>7</sup>
8. Satellite Dish, greater than thirty nine inches (39") in diameter<sup>8</sup>
9. Raising grazing of horses
10. Cemetery
11. Bed and Breakfast Inn
12. Boarding House, Hotel
13. Hotel, Minor<sup>6</sup>
14. Hotel, Major<sup>6</sup>
15. Private Residence Club Project and Conversion<sup>11</sup>
16. Office, General<sup>6</sup>,
17. Office, Moderate Intensive<sup>6,9</sup>
18. Office and Clinic, Medical<sup>6,10</sup>

19. Financial Institution, without drive up window<sup>6,10</sup>
20. Commercial Retail and Service, Minor<sup>6,10</sup>
21. Commercial Retail and Service, personal improvement<sup>6,10</sup>
22. Commercial, Resort Support<sup>6,10</sup>
23. Cafe or Deli<sup>6,10</sup>
24. Restaurant, Standard<sup>6,10</sup>
25. Restaurant, Outdoor Dining<sup>11</sup>
26. Outdoor Event<sup>11</sup>
27. Bar<sup>6,10</sup>
28. Hospital, Limited Care Facility<sup>6,9</sup>
29. Parking Area or Structure with five (5) or fewer spaces
30. Temporary Improvement<sup>11</sup>
31. Passenger Tramway Station and Ski Base Facility<sup>12</sup>
32. Ski Tow, Ski Lift, Ski Run, and Ski Bridge<sup>12</sup>
33. Recreation Facility, Public
34. Recreation Facility, Commercial<sup>6</sup>
35. Entertainment Facility, Indoor<sup>6,9</sup>
36. Commercial Stables, Riding Academy<sup>6,10</sup>
37. Master Planned Development with moderate income housing Density bonus<sup>6</sup>
38. Master Planned Development with residential and transient lodging Uses only<sup>6</sup>
39. Master Planned Development with Support Retail and Minor Service Commercial<sup>6</sup>
40. Fences greater than six feet (6') in height from Final Grade
41. Salt Lake City 2002 Winter Olympic Games Olympic Legacy Displays<sup>13</sup>

C. **PROHOBITED USES**. Any Use not listed above as an Allowed or Conditional Use is a prohibited Use.

<sup>1</sup>Nightly Rental of Lockout Units requires a Conditional Use permit.

<sup>2</sup>See LMC Chapter 15-4, Accessory Apartments.

<sup>3</sup>Nightly Rentals do not include the Use of Dwellings for Commercial Use.

<sup>4</sup>See LMC Chapter 15-4, Child Care Regulations

<sup>5</sup>Olympic Legacy Displays limited to those specific Structures approved under the SLOC/Park City Municipal Corporation Olympic Services Agreement and/or Olympic Master Festival License and placed on the original Property set forth in the services agreement and/or Master Festival License

<sup>6</sup>Subject to provisions of LMC Chapter 15-6, Master Planned Development.

<sup>7</sup>See LMC Chapter 15-4-14, Telecommunication Facilities.

<sup>8</sup>See LMC Chapter 15-4-13, Satellite Receiving Antennas.

<sup>9</sup>General Offices are only permitted with an approved Master Planned Development and may only be approved as the redevelopment of an existing Building or Property. In addition to meeting the necessary criteria in the LMC Chapter 15-6 MPD's, the Planning Commission must find that: a) the redevelopment of an existing Building or Property to a General Office use will substantially advance the objectives of Economic Element of the General Plan or other more specific neighborhood plans; b) it has minimized/eliminated any potential detrimental impact on the resort and/or resort-residential character of the RDM District and the Frontage Protection

Zone through careful planning and conditions of approval; c) it will not result in an intensification of use incompatible with neighboring developments; and d) it will not result in substantial increase in the existing trip generations for services and deliveries.

<sup>10</sup>Allowed only as a secondary or support Use to the primary Development or Use and intended as a convenience for residents or occupants of adjacent or adjoining residential Development.

<sup>11</sup>Requires an administrative Conditional Use permit.

<sup>12</sup>As part of an approved Ski Area Master Plan. See LMC Chapter 15-4-18, Passenger Tramways and Ski Base Facilities

<sup>13</sup>Olympic Legacy Displays limited to those specific Structures approved under the SLOC/Park City Municipal Corporation Olympic Services Agreement and/or Olympic Master Festival License and placed in an Area other than the original location set forth in the services agreement and/or Master Festival License.

<sup>14</sup>The Planning Director, or his designee shall, upon finding a Food Truck Location in compliance with LMC Chapters 15-1-8 and 15-1-9, issue the property owner a Food Truck Location administrative approval letter.

*Adopted by Ord. 00-51 on 9/21/2000*

*Amended by Ord. 02-24 on 6/27/2002*

*Amended by Ord. 02-38 on 9/12/2002*

*Amended by Ord. 04-39 on 3/18/2004*

*Amended by Ord. 06-76 on 11/9/2006*

## Exhibit F – LMC § 15-2.16-2 Uses in Recreation Commercial (RC) District

### 15-2.16-2 USES IN RECREATION COMMERCIAL (RC) DISTRICT

Uses in the RC District are limited to the following:

#### A. ALLOWED USES.

1. Single Family Dwelling
2. Duplex Dwelling
3. Triplex Dwelling
4. Secondary Living Quarters
5. Lockout Unit<sup>1</sup>
6. Accessory Apartment<sup>2</sup>
7. Nightly Rental<sup>3</sup>
8. Home Occupation
9. Child Care, In-Home Babysitting<sup>4</sup>
10. Child Care, Family<sup>4</sup>
11. Child Care, Family Group<sup>4</sup>
12. Child Care Center<sup>4</sup>
13. Accessory Building and Use
14. Conservation Activity
15. Agriculture
16. Bed & Breakfast Inn
17. Boarding House, Hostel
18. Hotel, Minor
19. Parking Area or Structure with four (4) or fewer spaces
20. Salt Lake City 2002 Winter Olympic Games Olympic Legacy Displays<sup>5</sup>
21. Food Truck Location<sup>11</sup>

#### B. CONDITIONAL USES.

1. Multi-Unit Dwelling
2. Group Care Facility
3. Public and Quasi-Public Institution, Church, and School
4. Essential Municipal and Public Utility Use, Facility, Service, and Structure
5. Telecommunications Antenna<sup>6</sup>
6. Satellite Dish Antenna, greater than thirty-nine inches (39") in diameter<sup>7</sup>
7. Raising, grazing of horses
8. Cemetery
9. Hotel, Major
10. Timeshare Project and Conversion
11. Timeshare Sales Office
12. Private Residence Club Project and Conversion<sup>9</sup>
13. Office, General<sup>8</sup>
14. Office, Moderate<sup>8</sup>
15. Office and Clinic, Medical<sup>8</sup>
16. Financial Institution without drive-up window<sup>8</sup>
17. Minor Retail and Service Commercial<sup>8</sup>

18. Retail and Service Commercial, personal improvement<sup>8</sup>
19. Transportation Service<sup>8</sup>
20. Neighborhood Market, without gasoline sales<sup>8</sup>
21. Café or Deli<sup>8</sup>
22. Restaurant, General<sup>8</sup>
23. Restaurant, Outdoor Dining<sup>8,9</sup>
24. Bar<sup>8</sup>
25. Hospital, Limited Care Facility<sup>8</sup>
26. Parking Area or Structure with five (5) or more spaces
27. Temporary Improvement<sup>9</sup>
28. Passenger Tramway Station and Ski Base Facility<sup>10</sup>
29. Ski Tow Rope, Ski Lift, Ski Run, and Ski Bridge<sup>10</sup>
30. Outdoor Events and Uses<sup>9</sup>
31. Recreation Facility, Public and Private<sup>8</sup>
32. Recreation Facility, Commercial<sup>8</sup>
33. Entertainment Facility, Indoor<sup>8</sup>
34. Commercial Stables, Riding Academy<sup>8</sup>
35. Master Planned Developments
36. Heliport<sup>8</sup>
37. Special Events<sup>9</sup>
38. Amenities Club

C. **PROHIBITED USES.** Any Use not listed above as an Allowed or Conditional Use is a prohibited Use.

<sup>1</sup>Nightly Rental of Lockout Units requires a Conditional Use permit

<sup>2</sup>See LMC Chapter 15-4, Supplemental Regulations for Accessory Apartments

<sup>3</sup>Nightly Rentals do not include the Use of dwellings for Commercial Uses

<sup>4</sup>See LMC Chapter 15-4-9, Child Care Regulations

<sup>5</sup>Olympic Legacy Displays limited to those specific Structures approved under the SLOC/Park City Municipal Corporation Olympic Services Agreement and/or Olympic Master Festival License and placed on the original Property set forth in the services agreement and/or Master Festival License. Requires an Administrative Permit.

<sup>6</sup>See LMC Chapter 15-4-14, Supplemental Regulations for Telecommunication Facilities

<sup>7</sup>See LMC Chapter 15-4-13, Supplemental Regulations for Satellite Receiving Antennas

<sup>8</sup>As support Use to primary Development or Use, subject to provisions of LMC Chapter 15-6, Master Planned Development

<sup>9</sup>Requires an Administrative or Administrative Conditional Use permit, see Section 15-4

<sup>10</sup>As part of an approved Ski Area Master Plan

<sup>11</sup>[The Planning Director, or his designee shall, upon finding a Food Truck Location in compliance with LMC Chapters 15-1-8 and 15-1-9, issue the property owner a Food Truck Location administrative approval letter.](#)

*Adopted by Ord. 00-51 on 9/21/2000*

*Amended by Ord. 02-38 on 9/12/2002*

*Amended by Ord. 04-39 on 3/18/2004*

*Amended by Ord. 06-76 on 11/9/2006*

*Amended by Ord. 09-10 on 3/5/2009  
Amended by Ord. 11-05 on 1/27/2011  
Amended by Ord. 15-35 on 10/12/2015*

## Exhibit G – LMC § 15-2.17-2 Uses in Regional Commercial Overlay (RCO) District

### 15-2.17-2 USES IN REGIONAL COMMERCIAL OVERLAY (RCO) DISTRICT

Uses in the RCO District are limited to the following:

#### A. ALLOWED USES.

1. Secondary Living Quarters
2. Lockout Unit<sup>1</sup>
3. Accessory Apartment<sup>2</sup>
4. Nightly Rental
5. Home Occupation
6. Child Care, In-Home Babysitting<sup>3</sup>
7. Child Care, Family<sup>3</sup>
8. Child Care, Family Group<sup>3</sup>
9. Accessory Building and Use
10. Conservation Activity
11. Agriculture
12. Parking Area or Structure with four (4) or fewer spaces
13. Recreation Facility, Private
14. Allowed Uses in the Underlying Zoning District
15. Salt Lake City 2002 Winter Olympic Games Olympic Legacy Displays<sup>4</sup>
16. Food Truck Location<sup>11</sup>

#### B. CONDITIONAL USES.

1. Multi-Unit Dwelling<sup>5</sup>
2. Group Care Facility<sup>5</sup>
3. Child Care Center<sup>3,5</sup>
4. Public and Quasi-Public Institution, Church and School<sup>5</sup>
5. Essential Municipal Public Utility Use, Facility, Service, and Structure<sup>5</sup>
6. Telecommunication Antenna<sup>6</sup>
7. Satellite Dish Antenna, greater than thirty-nine inches (39") in diameter<sup>7</sup>
8. Plant and Nursery stock products and sales<sup>5</sup>
9. Bed and Breakfast Inn<sup>5</sup>
10. Boarding House, Hostel<sup>5</sup>
11. Hotel, Minor<sup>5</sup>
12. Hotel, Major<sup>5</sup>
13. Private Residence Club Project and Conversion<sup>9</sup>
14. Timeshare Sales Office, off-site<sup>5</sup>
15. Office, General<sup>5</sup>
16. Office, Moderate Intensive<sup>5</sup>
17. Office, Intensive<sup>5</sup>
18. Office and Clinic, Medical<sup>5</sup>
19. Financial Institution, with and without drive-up window<sup>5,8</sup>
20. Retail and Service Commercial, Minor<sup>5</sup>
21. Retail and Service Commercial, personal improvement<sup>5</sup>
22. Retail and Service Commercial, Major<sup>5</sup>
23. Transportation Service<sup>5</sup>

24. Retail Drive-Up Window<sup>8</sup>
25. Neighborhood Convenience Commercial<sup>5</sup>
26. Commercial, Resort Support<sup>5</sup>
27. Gasoline Service Station<sup>5</sup>
28. Cafe, Deli<sup>5</sup>
29. Restaurant, General<sup>5</sup>
30. Restaurant, Outdoor Dining<sup>9</sup>
31. Outdoor Event<sup>9</sup>
32. Restaurant, Drive-up window<sup>8</sup>
33. Bar<sup>5</sup>
34. Hospital, Limited Care Facility<sup>5</sup>
35. Hospital, General<sup>5</sup>
36. Parking Area or Garage with five (5) or more spaces<sup>8</sup>
37. Temporary Improvement<sup>9</sup>
38. Passenger Tramway Station and Ski Base Facility<sup>5</sup>
39. Ski tow rope, ski lift, ski run, and ski bridge<sup>5</sup>
40. Recreation Facility, Public<sup>5</sup>
41. Recreation Facility, Commercial<sup>5</sup>
42. Entertainment, Indoor<sup>5</sup>
43. Master Planned Developments<sup>5</sup>
44. Heliport<sup>5</sup>
45. Salt Lake City 2002 Winter Olympic Games Olympic Legacy Displays<sup>10</sup>

C. **PROHIBITED USES.** Any Use not listed above as an Allowed or Conditional Use is a prohibited Use.

<sup>1</sup>Nightly Rental of Lockout Units requires a Conditional Use permit

<sup>2</sup>See LMC Chapter 15-4, Supplemental Regulations for Accessory Apartments

<sup>3</sup>See LMC Chapter 15-4-9 Child Care Regulations

<sup>4</sup>Olympic Legacy Displays limited to those specific Structures approved under the SLOC/Park City Municipal Corporation Olympic Services Agreement and/or Olympic Master Festival License and placed on the original Property set forth in the services agreement and/or Master Festival License.

<sup>5</sup>Subject to provisions of Chapter 15-6, Master Planned Developments

<sup>6</sup>See LMC Chapter 15-4-14, Supplemental Regulations for Telecommunication Facilities

<sup>7</sup>See LMC Chapter 15-4-13, Supplemental Regulations for Satellite Receiving Antennas

<sup>8</sup>See Section 15-2.18-5 criteria for drive-up windows

<sup>9</sup>Requires an administrative Conditional Use permit

<sup>10</sup>Olympic Legacy Displays limited to those specific Structures approved under the SLOC/Park City Municipal Corporation Olympic Services Agreement and/or Olympic Master Festival License and placed in an Area other than the original location set forth in the services agreement and/or Master Festival License.

<sup>11</sup> The Planning Director, or his designee shall, upon finding a Food Truck Location in compliance with LMC Chapters 15-1-8 and 15-1-9, issue the property owner a Food Truck Location administrative approval letter.

*Adopted by Ord. 00-51 on 9/21/2000  
Amended by Ord. 02-38 on 9/12/2002  
Amended by Ord. 04-39 on 9/23/2004  
Amended by Ord. 06-76 on 11/9/2006*

## Exhibit H – LMC § 15-2.18-2 Uses in General Commercial (GC) District

### 15-2.18-2 USES IN GENERAL COMMERCIAL (GC) DISTRICT

Uses in the GC District are limited to the following:

#### A. ALLOWED USES.

1. Secondary Living Quarters
2. Lockout Unit<sup>1</sup>
3. Accessory Apartment<sup>2</sup>
4. Nightly Rental
5. Home Occupation
6. Child Care, In-Home Babysitting<sup>3</sup>
7. Child Care, Family<sup>3</sup>
8. Child Care, Family Group<sup>3</sup>
9. Child Care Center<sup>3</sup>
10. Accessory Building and Use
11. Conservation Activity
12. Agriculture
13. Plant and Nursery Stock production and sales
14. Bed & Breakfast Inn
15. Boarding House, Hostel
16. Hotel, Minor
17. Hotel, Major
18. Office, General
19. Office, Moderate Intensive
20. Office, Intensive
21. Office and Clinic, Medical and Veterinary Clinic
22. Financial Institution without a drive-up window
23. Commercial, Resort Support
24. Retail and Service Commercial, Minor
25. Retail and Service Commercial, Personal Improvement
26. Retail and Service Commercial, Major
27. Cafe or Deli
28. Restaurant, General
29. Hospital, Limited Care Facility
30. Parking Area or Structure with four (4) or fewer spaces
31. Parking Area or Structure with five (5) or more spaces
32. Recreation Facility, Private
33. Food Truck Location<sup>10</sup>

#### B. CONDITIONAL USES.

1. Single Family Dwelling
2. Duplex Dwelling
3. Triplex Dwelling
4. Multi-Unit Dwelling
5. Group Care Facility
6. Public and Quasi-Public Institution, Church, and School

7. Essential Municipal Public Utility Use, Facility, Service, and Structure
8. Telecommunication Antenna<sup>4</sup>
9. Satellite Dish Antenna, greater than thirty-nine inches (39") in diameter<sup>5</sup>
10. Timeshare Project and Conversion
11. Timeshare Sales Office, off-site within an enclosed Building
12. Private Residence Club Project and Conversion<sup>8</sup>
13. Financial Institution with a Drive-up Window<sup>6</sup>
14. Retail and Service Commercial with Outdoor Storage
15. Retail and Service Commercial, Auto Related
16. Transportation Service
17. Retail Drive-Up Window<sup>6</sup>
18. Gasoline Service Station
19. Restaurant and Cafe, Outdoor Dining<sup>7</sup>
20. Restaurant, Drive-up Window<sup>6</sup>
21. Outdoor Event<sup>7</sup>
22. Bar
23. Sexually Oriented Businesses<sup>8</sup>
24. Hospital, General
25. Light Industrial Manufacturing and Assembly
26. Temporary Improvement<sup>7</sup>
27. Passenger Tramway and Ski Base Facility
28. Ski tow rope, ski lift, ski run, and ski bridge
29. Commercial Parking Lot or Structure
30. Recreation Facility, Public
31. Recreation Facility, Commercial
32. Indoor Entertainment Facility
33. Master Planned Development with moderate housing density bonus<sup>9</sup>
34. Master Planned Developments<sup>9</sup>
35. Heliport
36. Temporary Sales Trailer in conjunction with an active Building permit for the Site.<sup>8</sup>
37. Fences greater than six feet (6') in height from Final Grade<sup>7</sup>
38. Household Pet, Boarding<sup>7</sup>
39. Household Pet, Daycare<sup>7</sup>
40. Household Pet, Grooming<sup>7</sup>

C. **PROHIBITED USES**. Any Use not listed above as an Allowed or Conditional Use is a prohibited Use.

<sup>1</sup>Nightly rental of Lockout Units requires Conditional Use permit

<sup>2</sup>See LMC Chapter 15-4, Supplemental Regulations for Accessory Apartments

<sup>3</sup>See LMC Chapter 15-4-9 Child Care Regulations

<sup>4</sup>See LMC Chapter 15-4-14, Supplemental Regulations for Telecommunication Facilities

<sup>5</sup>See LMC Chapter 15-4-13, Supplemental Regulations for Satellite Receiving Antennas

<sup>6</sup>See Section 2-18-6 for Drive-Up Window review

<sup>7</sup>Requires an administrative Conditional Use permit

<sup>8</sup>See Section 2-17-8 for additional criteria.

<sup>9</sup>Subject to provisions of LMC Chapter 15-6, Master Planned Development

<sup>10</sup> The Planning Director, or his designee shall, upon finding a Food Truck Location in compliance with LMC Chapters 15-1-8 and 15-1-9, issue the property owner a Food Truck Location administrative approval letter.

*Adopted by Ord. 00-51 on 9/21/2000*

*Amended by Ord. 04-39 on 9/23/2004*

*Amended by Ord. 06-76 on 11/9/2006*

*Amended by Ord. 14-57 on 11/20/2014*

## Exhibit I – LMC § 15-2.19-2 Uses in Light Industrial (LI) District

### 15-2.19-2 USES IN LIGHT INDUSTRIAL (LI) DISTRICT

Uses in the LI District are limited to the following:

#### A. ALLOWED USES.

Secondary Living Quarters

1. Accessory Apartment<sup>1</sup>
2. Nightly Rental
3. Home Occupation
4. Child Care, In-Home Babysitting<sup>2</sup>
5. Child Care, Family<sup>2</sup>
6. Child Care, Family Group<sup>2</sup>
7. Child Care Center<sup>2</sup>
8. Agriculture
9. Plant and Nursery Stock
10. Office, General
11. Office, Moderate Intensive
12. Office, Intensive
13. Financial Institution without drive-up window
14. Retail and Service Commercial, Minor
15. Retail and Service Commercial, Personal Improvement
16. Retail and Service Commercial, Major
17. Commercial, Resort Support
18. Hospital, Limited Care
19. Parking Area or Structure with four (4) or fewer spaces
20. Recreation Facility, Private
21. Food Truck Location<sup>8</sup>

#### B. CONDITIONAL USES.

1. Multi-Unit Dwelling
2. Group Care Facility
3. Child Care Center<sup>2</sup>
4. Public and Quasi-Public Institution, Church, and School
5. Essential Municipal Public Utility Use, Facility, Service, and Structure
6. Telecommunication Antenna<sup>3</sup>
7. Satellite Dish Antenna, greater than thirty-nine inches (39") in diameter<sup>4</sup>
8. Accessory Building and Use
9. Raising, grazing of horses
10. Bed and Breakfast Inn
11. Boarding House, Hostel
12. Hotel, Minor
13. Private Residence Club Project and Conversion<sup>6</sup>
14. Office and Clinic, Medical and Veterinary Clinic
15. Financial Institutions with Drive-Up Window<sup>5</sup>
16. Retail and Service Commercial with Outdoor Storage
17. Retail and Service Commercial, Auto-Related

18. Transportation Services
19. Retail Drive-Up Window<sup>5</sup>
20. Gasoline Service Station
21. Café or Deli
22. Restaurant, General
23. Restaurant, Outdoor Dining
24. Restaurant, Drive-Up Window<sup>5</sup>
25. Outdoor Event<sup>6</sup>
26. Bar
27. Hospital, General
28. Light Industrial Manufacturing and Assembly Facility
29. Parking Area or Structure with five (5) or more spaces
30. Temporary Improvement<sup>6</sup>
31. Passenger Tramway Station and Ski Base Facility
32. Ski Tow Rope, Ski Lift, Ski Run, and Ski Bridge
33. Recreation Facility, Public
34. Recreation Facility, Commercial
35. Entertainment Facility, Indoor
36. Commercial Stables, Riding Academy
37. Master Planned Developments<sup>7</sup>
38. Heliports
39. Commercial Parking Lot or Structure
40. Temporary Sales Office, in conjunction with an active Building permit.
41. Fences and Walls greater than six feet (6') in height from Final Grade<sup>6</sup>
42. Household Pet, Boarding<sup>6</sup>
43. Household Pet, Daycare<sup>6</sup>
44. Household Pet, Grooming<sup>6</sup>

C. **PROHIBITED USES.** Any Use not listed above as an Allowed or Conditional Use is a prohibited Use.

<sup>1</sup>See LMC Chapter 15-4, Supplemental Regulations for Accessory Apartments

<sup>2</sup>See LMC Chapter 15-4-9 Child Care Regulations

<sup>3</sup>See LMC Chapter 15-4-14, Supplemental Regulations for Telecommunication Facilities

<sup>4</sup>See LMC Chapter 15-4-13, Supplemental Regulations for Satellite Receiving Antennas

<sup>5</sup>See Section 2.19-8 for Drive-Up Window review criteria

<sup>6</sup>Subject to an administrative Conditional Use permit.

<sup>7</sup>Subject to provisions of LMC Chapter 15-6, Master Planned Development.

<sup>8</sup>The Planning Director, or his designee shall, upon finding a Food Truck Location in compliance with LMC Chapters 15-1-8 and 15-1-9, issue the property owner a Food Truck Location administrative approval letter.

*Adopted by Ord. 00-51 on 9/21/2000*

*Amended by Ord. 04-39 on 9/23/2004*

*Amended by Ord. 06-76 on 11/9/2006*

*Amended by Ord. 14-57 on 11/20/2014*

## Exhibit J – LMC § 15-2.22-2 Uses in Public Use Transition (PUT) District

### 15-2.22-2 USES IN PUBLIC USE TRANSITION (PUT) DISTRICT

Uses in the Public Use Transition District are limited to the following:

#### A. ALLOWED USES.

1. Municipal/Institutional Accessory Building and Use 600 sf or less
2. Conservation Activity
3. Parking Lot, Public or Private with four (4) or fewer spaces
4. Public Utility or Essential Services
5. Public Assembly Uses
6. Outdoor Events
7. Food Truck Location<sup>5</sup>

#### B. CONDITIONAL USES.

1. Public and Quasi-Public Institution, Church, School, Post Office
2. Entertainment Facility, Outdoor
3. Essential Municipal Public Utility Use, Facility, or Service Structure
4. Parking Area or Structure for five (5) or more cars
5. Liquor Store
6. Commercial Retail and Service, Minor
7. Outdoor Recreation Equipment
8. Outdoor Grills/Beverage Service Stations
9. Restaurant, Outdoor Dining<sup>1</sup>
10. Restaurant, Café or Deli
11. Accessory Building or Use greater than 600 sf
12. Telecommunication Antenna<sup>2</sup>
13. Satellite Dish, greater than thirty-nine inches (39”) in diameter<sup>3</sup>
14. Temporary Improvement/Outdoor Use
15. Salt Lake City 2002 Winter Olympic Legacy Displays<sup>4</sup>
16. Master Planned Developments
17. Passenger Tramways, ski towers, and ski lift facilities.

C. PROHIBITED USES. Any Use not listed above as an Allowed or Conditional Use is a prohibited Use.

<sup>1</sup>Required Administrative Conditional Use permit

<sup>2</sup>See LMC Chapter 15-4-14, Supplemental Regulations for Telecommunication Facilities

<sup>3</sup>See LMC Chapter 15-4-13, Supplemental Regulations for Satellite Receiving Antennas

<sup>4</sup>Olympic Legacy Displays limited to those specific Structures approved under the SLOC/Park City Municipal Corporation Olympic Services Agreement and/or Olympic Master Festival License and placed in an Area other than the original location set forth in the services agreement and/or Master Festival License.

<sup>5</sup>The Planning Director, or his designee shall, upon finding a Food Truck Location in compliance with LMC Chapters 15-1-8 and 15-1-9, issue the property owner a Food Truck Location administrative approval letter.

*Adopted by Ord. 05-12 on 3/3/2005*

## Exhibit K – LMC § 15-2.23-2 Uses in Community Transition (CT) District

### 15-2.23-2 USES IN COMMUNITY TRANSITION (CT) DISTRICT

Uses in the Community Transition District are limited to the following:

#### A. ALLOWED USES.

1. Conservation Activities
2. Home Occupation
3. In-home Babysitting
4. Family Child Care
5. Secondary Living Quarters
6. Agriculture
7. Food Truck Location<sup>2</sup>

#### B. ADMINISTRATIVE CONDITIONAL USES.

1. Trails and Trailhead Improvements
2. Outdoor Recreation Equipment
3. Essential Public Utility Use, Service or Structure less than 600 sf
4. Accessory Buildings less than 600 sf
5. Parking Areas with 4 or fewer spaces
6. Outdoor Events and Outdoor Music, see Section 15-4
7. Temporary Improvement
8. Outdoor Dining and support retail associated with support Uses with an MPD
9. Special Events
10. Fences and Walls, see Section 15-4
11. Anemometer and Anemometer Tower

#### C. CONDITIONAL USES.

1. Master Planned Developments (MPDs)
2. Public, Quasi-Public, Civic, Municipal Uses
3. General Acute Hospital
4. Alternative Professional Health-related Services
5. Athletic Training and Testing Offices and Facilities
6. Athletic Program Administrative Offices
7. Support Short-Term Athlete Housing or lodging associated with an approved recreation facility (within an approved MPD)
8. Accredited Physician Office Space
9. Accredited Medical & Dental Clinics
10. Medical Heliport
11. Group Care Facility
12. Ancillary Support Commercial (within an approved MPD)
  - a. Gift Shop
  - b. Dispensing pharmacy
  - c. Medical supply
  - d. Restaurant
  - e. Deli
  - f. Outdoor Grills/ Beverage Service Stations

- g. Child Care Center
- 13. Recreation Facility, Public and Private
- 14. Recreation Facility, Commercial
- 15. Park and Ride Lot
- 16. Municipal/Institutional Accessory Building and Use
- 17. Parking Lot, Public or
- 18. Public Utility or Essential Services
- 19. Single Family Dwelling (with an approved MPD<sup>1</sup>)
- 20. Duplex Dwelling (with an approved MPD<sup>1</sup>)
- 21. Multi-Unit Dwelling (with an approved MPD<sup>1</sup>)
- 22. Telecommunication Antenna
- 23. Transit Facilities
- 24. Parking Areas, Lots, and Structures with more than five (5) Parking Spaces
- 25. Raising and Grazing of Horses
- 26. Commercial Riding Stables
- 27. Small Energy Wind Systems

D. **PROHIBITED USES**. Any Use not listed above as an Allowed or Conditional Use is a prohibited Use.

<sup>1</sup>Residential Uses cannot exceed 1 unit/acre

<sup>2</sup>The Planning Director, or his designee shall, upon finding a Food Truck Location in compliance with LMC Chapters 15-1-8 and 15-1-9, issue the property owner a Food Truck Location administrative approval letter.

*Adopted by Ord. 06-48 on 6/29/2006*

*Amended by Ord. 07-25 on 4/19/2007*

*Amended by Ord. 09-10 on 3/5/2009*

## Exhibit L – LMC § 15-15 Defined Terms

### 15-15 DEFINED TERMS

#### **FOOD TRUCK.**

- (a) “Food Truck” means a fully encased food service establishment:
  - (i) on a motor vehicle or on a trailer that a motor vehicle pulls to transport; and
  - (ii) from which a food truck vendor, standing within the frame of the vehicle, prepares, cooks, sells, or serves food or beverages for immediate human consumption; and
  - (iii) does not include the sale of any products other than food and beverages for human consumption.
- (b) “Food truck” does not include a food cart or an ice cream truck.
- (c) “Food cart” means a cart:
  - (i) that is not motorized; and
  - (ii) that a vendor, standing outside the frame of the cart, uses to prepare, sell, or serve food or beverages for immediate human consumption.
- (d) “Ice cream truck” means a fully encased food service establishment:
  - (i) on a motor vehicle or on a trailer that a motor vehicle pulls to transport;
  - (ii) from which a vendor, from within the frame of the vehicle, serves ice cream;
  - (iii) that attracts patrons by traveling through a residential area and signaling the truck’s presence in the area, including by playing music; and
  - (iv) that may stop to serve ice cream at the signal of a patron.

**FOOD TRUCK LOCATION.** The location on private property where one or more Food Trucks may park and sell product for ten (10) hours or more a week. Food Truck Locations may not occupy code required parking for previously approved Development Activity.

## Planning Commission Staff Report

**Subject:** 638 Park Avenue (Kimball Garage)  
**Author:** Anya Grahn, Senior Historic District Planner  
**Project Number:** PL-16-03412  
**Date:** October 10, 2018  
**Type of Item:** Administrative – City Council Remand of an appeal of Planning Commission’s Approval of a Conditional Use Permit (CUP) for a Private Event Facility

### Summary Recommendations

Staff recommends that the Planning Commission discuss the remand of the appeal of the Conditional Use Permit (CUP) for a Private Event Facility at the Historic Kimball Garage at 638 Park Avenue, hold a public hearing, and consider approving the CUP for the Private Event Facility pursuant to the findings of fact, conclusions of law, and conditions of approval as stated in this report.

### Topic

**Applicant:** CPP Kimball LLC represented by Tony Tyler and Architect Craig Elliot  
**Location:** Historic Kimball Garage at 638 Park Avenue  
**Zoning:** Historic Recreation Commercial (HRC), Heber Avenue Subzone  
**Adjacent Land Use:** Residential single-family and multi-family; commercial  
**Reason for review:** Appeals of Planning Commission’s decisions are reviewed by the City Council; City Council remanded this CUP back to the Planning Commission on March 30, 2017.

### Summary of Proposal

On September 19, 2016, the Planning Department received an application for a Conditional Use Permit (CUP) for a Private Event Facility at 638 Park Avenue. The applicant is rehabilitating the existing historic building for Retail and other Commercial uses and is constructing an approximately 22,800 square foot addition to the east, adjacent to Main Street. The upper level of the addition is proposed to be used as a 3,695 square foot Private Event Facility, attached to a 2,179 square foot rooftop terrace. The CUP application is required to allow Private Event Facility uses at this location. The building is currently under construction and is not subject to the CUP. Only the proposed use of the Private Event Space in the new addition and on the rooftop deck is subject to the CUP review. This item is an appeal of the Planning Commission’s December 14, 2016 approval that was appealed to City Council and then remanded back to the Commission for further review.

## **Background**

### **Recent History of Applications**

Below is a timeline overview of this application:

March 20, 2016	The Planning Director found that the Kimball Art Center was current in their assessment to the Main Street Parking Special Improvement District as of January 1, 1984, for parking requirements up to a Floor Area Ratio (FAR) of 1.5.
May 19, 2016	The Park City Council approved the Kimball on Main plat amendment for this property at 638 Park Avenue on (See <a href="#">Ordinance 2016-21</a> ). The plat was recorded on February 3, 2017.
June 20, 2016	Historic District Design Review (HDDR) for the rehabilitation of the historic Kimball Garage and construction of a new addition was approved.
June 30, 2016	Park City Museum and Historical Society submits an appeal to the HDDR approval, objecting to a number of issues, including the removal of one (1) of the two (2) bow-string arches forming the roof of the building.
October 18, 2016	The Board of Adjustment (BOA) met and denied the appeal, and upheld staff's HDDR approval [ <a href="#">Staff Report (page 23)</a> and <a href="#">Minutes</a> (page 1)].
September 19, 2016	The Planning Department received an application for a Conditional Use Permit (CUP) for a Private Event Facility at 638 Park Avenue.
November 9, 2016	Planning Commission reviews CUP for Private Event Facility [see <a href="#">Staff Report</a> (starting page 23) and <a href="#">Minutes</a> (starting page 28)]. Planning Commission continues the item to December for further discussion.
December 14, 2016	Planning Commission reviews CUP [see <a href="#">Staff Report</a> (starting page 95) and <a href="#">Minutes</a> (starting page 60)]. They voted unanimously (6-0) to approve the CUP for Private Event Facility with various conditions of approval.
December 22, 2016	An appeal of the Planning Commission approval of the CUP filed by Sanford Melville.
February 16, 2017	Building permit was issued.
March 30, 2017	Park City Council heard the appeal [ <a href="#">Staff Report</a> (page 151), <a href="#">Minutes</a> (page 9), and <a href="#">Audio</a> ]. The Park City Council was overall not in favor of the CUP as they found there were reasonably anticipated detrimental effects of the proposed CUP that could not be substantially mitigated. City Council remanded the appeal back to the Planning Commission for

	further review.
September 27, 2017	Staff held a work session with the Planning Commission to receive additional direction [ <a href="#">Staff Report</a> (starting page 202) and <a href="#">Minutes</a> (starting page 3)].
June 13, 2018	Planning Commission reviewed the CUP with updated recommendations for Conditions of Approval [ <a href="#">Staff Report</a> (starting page 17) and <a href="#">Minutes</a> (starting page 3)].
August 8, 2018	Planning Commission has a work session that includes a site visit to the rooftop deck area [ <a href="#">Staff Report</a> (starting page 16) and <a href="#">Minutes</a> (starting page 1)].

### **Process**

The Park City Council has remanded this appeal back to the Planning Commission for additional review of the CUP. The Planning Commission will review the scope of the remand on the CUP and make a determination on the CUP. The scope of the Planning Commission review is limited to the remand. See Exhibit A Council Remand.

Any appeals of the Planning Commission’s determination on the remand may be appealed within 30 days to City Council.

### **Analysis**

On March 30, 2017, the City Council remanded this item back to the Planning Commission for further review (Exhibit A). The Planning Commission then reviewed the CUP during their work session on September 27, 2017; regular session on June 13, 2018; and their site visit on August 8, 2018. During the June 2018 Planning Commission meeting, the applicant requested that this item be continued in order to allow them additional time to propose additional draft Conditions of Approval that would further mitigate impacts of the Private Event Space.

Pursuant to [LMC 15-1-10 Conditional Use Review Process](#), “There are certain Uses that, because of unique characteristics or potential impacts on the municipality, surrounding neighbors, or adjacent land Uses, may not be Compatible in some Areas or may be Compatible only if certain conditions are required that mitigate or eliminate the detrimental impacts. The Planning Department will evaluate all proposed Conditional Uses and may recommend conditions of approval to preserve the character of the zone, and to mitigate potential adverse effects of the Conditional Use. A Conditional Use shall be approved if reasonable conditions are proposed, or can be imposed, to mitigate the reasonably anticipated detrimental effects of the proposed Use in accordance with applicable standards. If the reasonable anticipated detrimental effects of a proposed Conditional Use cannot be substantially mitigated by the proposal or imposition of reasonable conditions to achieve compliance with applicable standards, the Conditional Use may be denied.” The Conditional Use review items are outlined in [LMC 15-1-10\(E\)](#).

In the June 2018 Planning Commission [Staff Report](#) (starting page 17), staff had presented City Council’s and Planning Commission’s concerns and then explained how

the applicant intended to mitigate these concerns. Staff heard from Planning Commissioners in June that there were two main issues they believed the applicant had not yet resolved—(1) Noise and (2) Traffic, Loading/Unloading, and Parking.

Beginning in June 2018, staff has been meeting with the applicant to draft additional Conditions of Approval to mitigate the concerns brought up by the public and the Planning Commission.

The Planning Commissioners agreed that other issues such as the tent had been mitigated by its removal from the CUP request. Some Commissioners believed that the basement storage space intended to mitigate the need for loading/unloading supplies and equipment was unrealistic. They also wanted to see a more robust parking management plan that included ways of utilizing off-site parking areas for large numbers of people. One commissioner asked that the threshold of 141 people on the rooftop terrace be reduced further to help mitigate noise. The Commissioners directed staff to complete third party reviews for acoustics and traffic.

Staff provided a more robust analysis in the June 2018 Planning Commission [Staff Report](#) (starting page 17) of previous City Council and Planning Commission discussions. The outline below is a brief summary on the two remaining topics that needed to be addressed.

1. **NOISE**

***City Council Direction***

During the appeal in March 2017, City Council determined this site had a geographical problem as it faced uphill residential neighborhoods. They worried that this use would exceed the allowance of the noise ordinance and adversely impact the residential neighborhood, forcing the neighbors to bear an unreasonable enforcement role on weekends and after-hours. City Council also did not agree that the glass railings and walls would absorb sound as intended; rather they would amplify sound. City Council also recommended more restrictive event uses, more limited hours, and additional methods limiting operations and preventing the use from becoming a nuisance.

***Planning Commission Feedback***

During the September 2017 Work Session, the Planning Commission echoed City Council's concerns about the geographic location of the site and the nuisance of noise generated by the event space on the surrounding residential neighborhood. The Planning Commission also questioned the designed solutions to mitigate noise as they believe additional analysis would be needed to determine whether the glass railings and wall would amplify or buffer the noise. They found the noise mitigation plan to be technically advanced, but recognized that the Commissioners needed a better understanding of how the noise mitigation tools functioned. Most importantly, the Planning Commission requested time limitations on the use of the outdoor event space.

In June 2018, the Planning Commission reiterated many of these sentiments. They asked that the occupancy of 141 people on the deck be reduced further to help mitigate the noise. They also requested a third party acoustical review of the applicant's proposal as there were concerns about the Henderson Study. They did not believe the noise had been substantially mitigated.

***Applicant's Response (as outlined in the June 2018 Planning Commission packet)***

The applicant had commissioned Henderson Engineers to conduct a third-party noise study, and this was presented to the Planning Commission in June. The Henderson report found that 150 guests with 2 acoustic musicians on the rooftop terrace and 75 people talking simultaneously would generate 72 dBA for "loud talking." The applicant argued that the Henderson study demonstrated that any event at maximum capacity on the terrace would not exceed the Maximum Permissible Sound Levels for the Commercial District, which vary from 60 dBA to 65 dBA depending on the time of the day. They argued the proposed use would comply with the City's [Noise Ordinance](#).

Additionally, design features have been incorporated throughout the Private Event Facility to further mitigate any noise. Sound traps in the soffit, acoustical baffles in the ventilation outlets, insulated glass, and automatic closing devices on the exterior doors have been installed to reduce sound reflectivity and reduce noise. The applicant has further argued that the proposed landscape buffers surrounding the south and west sides of the rooftop terrace, the glass railings, and the barrel vault to the west of the rooftop terrace will all further help absorb and mitigate noise from traveling into the residential neighborhood. The applicant has also proposed sound limiting and monitoring equipment, training procedures for event staff, and robust complaint procedures as part of a Noise Management Plan to further ensure compliance with the City's Noise Ordinance.

The hours of operation for the CUP will be 8am to midnight for the interior event space and 11am to 10pm for the outdoor space, also consistent with the City's Noise Ordinance.

***Staff's Response***

Third Party Review of Acoustical Study:

Staff contracted Acoustical Engineer Joe Morris of BNA Consulting to conduct an acoustical study from the rooftop deck of the Kimball (See Exhibit C). The acoustical study found that the sound levels from traffic and construction noise largely masked any sounds made by people on the rooftop deck. The acoustical engineer confirmed the findings of the Henderson Report in that the amount of noise generated by guests and musicians on the rooftop deck would not exceed the City's Noise Ordinance. He further found that the noise would dissipate over the distance from the terrace to the residential property lines, scattering over the barrel-vaulted roof of the Kimball. It would be further masked by existing traffic and environmental noise.

He did find, however, that noise levels could exceed the City's Noise Ordinance on cold nights when there is snow on the ground. The cold air and snow would carry the sound more quickly over longer distances during the winter than during warmer seasons. He recommended limiting how frequently the doors of the Kimball would be open during events on the second floor on cold nights. He also recommended further mitigation when heavy, low end music or music with lower frequencies or bass are played.

#### Staff's Acoustical Study:

The Planning, Building, and Police Departments also conducted a sound study on Tuesday, September 18<sup>th</sup> at 9pm (see Exhibit D). The purpose of staff's acoustical analysis was to create conditions reflective of an average event activity (music playing during the evening at cooler temperatures). Staff recognized that while many factors can affect how sound travels over a distance, the amount of sound dissipation over distance created a situation within which activities could be hosted and maintained on the terrace in compliance with the noise ordinance. Staff also found that the installation of the guardrail and landscaping bordering the rooftop terrace may further mitigate the amount of sound migrating away from the rooftop terrace. Staff concluded that sound pressure levels on the terrace of 90 dBA, which is permitted under [Municipal Code 6-3-11](#) Relief from Restrictions, would likely be inappropriate; 90dBA is typically the exception that is granted for Special Events such as Silly Sunday Market.

Staffers are concerned about the private event facility use creating a situation where noise violations are possible. Additionally, regardless of noise violations, the proximity of the site in relationship to residential properties creates a high probability for long term noise fatigue which staff will not have an ability to enforce against.

#### Consistency with other CUPs for similar uses:

Staff has also researched the CUP approvals for similar spaces that regularly hold events and has found the following:

- The CUPs for both Park Meadows Country Club (PMCC) and Town Lift require that the entertainment cease *prior to* 10pm.
- Harry O's (now Park City Live) CUP requires that an Event Management Plan be prepared and reviewed by the Planning Department; it required that the plan include provisions for ticket sales and arriving and departing guests for those times when the establishment was operating over and above normal night club use and occupancy levels.
- Both the PMCC and Town Lift CUPs requires advance written notification to the Planning Department prior to each event with details to ensure consistency with the CUP approval. The Entertainment Facility at the Yard requires a detailed submittal be provided two (2) weeks (ten business days) before any event for review and approval by the Chief Building Official and the Planning Department.

Recommended Conditions of Approval:

Based on these findings, staff has worked with the applicant to create the following Conditions of Approval for the CUP for the Private Event Space:

*#8. The rooftop terrace shall not be used for activities that may create dust or odor, such as but not limited to cooking.*

*#9. Programmed activity and occupancy of all outdoor spaces shall cease at 10pm. The hours of operation of the rooftop terrace shall be limited to 11am to 10pm.*

*#10. The owner shall orient the activities so as to minimize sound impacts to the neighborhoods and the applicant shall monitor the following:*

- a. The owner, or his/her designee, shall provide on-site management for each aspect of the event.*
- b. The owner shall be responsible to ensure that the sound system maintains level adjustments not to exceed provisions of the Park City Noise Ordinance for the outdoor use.*
- c. The owner shall install noise limiting equipment in all areas where events will take place. This equipment is linked into the electrical supply which feeds the music systems and will cut the supply if a dBA reading exceeds the threshold levels of music noise with the City noise ordinance. The equipment works on a traffic light sequence and will be visible to performers, guests and event staff. The red banding will only be tolerated for a three seconds before the system shuts down automatically.*
- d. Owner shall not allow the use of music on the outdoor balcony after 10 pm, shall limit occupancy on the outdoor balcony to no more than 141 occupants, and shall operate the facility in accordance with the Noise Management Plan.*
- e. For events ending after 9 pm, loading of off-site equipment and trash on Heber Avenue shall occur the next morning, not the night of the event. Clean-up for the rooftop terrace shall remain subject to the Noise Ordinance following the programmed event.*
- f. The operator shall be required to maintain a copy of the Conditions of Approval of this CUP onsite should the Police Department request them.*

*#11. The owner shall not permit or provide either live or recorded amplified music within the interior of the space without first having closed all exterior doors and windows of the licensed premise. Doors may be opened to provide ingress and egress, but shall not be blocked in the open position to provide ventilation. Doors shall be equipped with automatic closing devices to keep them in the closed position except to permit ingress and egress of patrons.*

*#12. No elevated stages or elevated free-standing speakers exceeding the height of the glass railing for performances shall be allowed on the outdoor spaces of the event center.*

*#13. Outdoor speakers shall not cause to exist any loud speaker or sound amplification equipment on the outdoor balcony or rooftop terrace associated*

*with the licensed premises other than speaker systems or sound amplification equipment in conjunction with approved outdoor dining. Music is limited from 11 am to 10 pm and may not carry beyond the boundaries of the rooftop terrace or balcony as regulated by the Noise Ordinance.*

*#14. In accordance with Park City Municipal Code 6-3-9, as may be amended, any violation shall be measured at a distance of at least twenty-five feet (25') from the source of the device upon public property or within the public right-of-way or twenty-five feet (25') from the property line if upon private property, and shall be measured on a decibel or sound level meter of standard design and quality operated on the "A" weighting scale. A measurement of 65 decibels shall be considered to be excessive and unusually loud.*

*#15. The operator shall provide advanced written notification to the Park City Planning Department of each event they plan to hold with an occupancy load of 250 or more. The operational description shall be submitted at least two (2) weeks (ten business days) before any event for review and approval of mitigation strategies, not to be unreasonably withheld, by the Chief Building Official, Transportation, Engineering, and Planning Departments. Event operator contact information shall be provided to the Park City Police Department for contact in case of violations. Additionally, the applicant should provide:*

- a. An Event Management Plan shall be prepared and reviewed by the Planning, Building, Engineering, and Police Departments for each event with an occupancy load of 250 or more. The Event Management Plan shall include provisions for ticket sales (if applicable); health and safety; participant behavior and control; security; parking; transportation; and traffic. Security shall be provided for events over 250 occupants, on a ratio of 1 security personnel per 50 guests unless otherwise approved by the Park City Police Department.*
- b. A Traffic Management Plan shall be prepared to identify traffic flow, traffic control (if applicable), as well as parking activities and alternatives to parking for all events with occupancy loads of 250 or greater. The plan shall address private shuttle service, enforcement of drop-off and loading zones, stewards directing parking patrons to correct locations, and other mitigation strategies.*
- c. The City reserves the right to request additional mitigation strategies for events exceeding 250 occupants should the City find that the applicant has not adequately mitigated the impacts of said event.*

After further staff analysis, it was determined that it was unlikely that the Chief of Police and Building Official would approve a permit for relief of the noise restrictions, in accordance with [Municipal Code 6-3-11](#) due the location of the Private Event Facility and its proximity to residential neighborhoods. Special consideration may be taken for Special Event permits and/or Master Festival licenses.

## 2. LOADING, TRAFFIC, AND PARKING

### ***City Council Direction***

The City Council did not find that traffic, loading, and parking demands were sufficiently mitigated. They feared that this use would only exasperate the already congested intersections of Main Street and Heber Avenue as well as Park Avenue and Heber Avenue. They did not want to see overflow parking on Park Avenue that would create additional duress for the residential neighborhood.

### ***Planning Commission Direction***

During the September 2017 work session, the Planning Commission found that traffic mitigation needed to be reviewed more closely, with special consideration of the proximity of congested intersections along Park Avenue, Heber Avenue, and Main Street. They worried that added traffic generated by the Private Event Facility would block bus traffic, and they requested a viable plan for mitigating the traffic. They worried that loading/unloading areas would block sidewalk traffic, create large crowds that would contribute to increased noise levels, and they wanted to see a designated loading/unloading zone for Transportation Network Companies (TNC) to pull off the street altogether. There was also concerns about mitigating the parking generated by the event as they did not believe it was appropriate for the applicant to perpetually rely on purchasing parking spaces from the City for its events. They were also not supportive of the applicant's proposal to reduce parking or permanently convert parking along Heber into a 15-minute loading/unloading zone.

During the June 2018 meeting, the Planning Commission once again reiterated that they did not believe the loading/unloading, traffic, and parking issues had been resolved. They wanted to see a parking mitigation plan that included ways of using off-site parking areas for larger parties. They requested a third party traffic study.

### ***Applicant's Response (as outlined in the June 2018 Planning Commission packet)***

The applicant continues to refer to the March 20, 2016, Planning Director determination that found that parking had been provided up to a Floor Area Ratio (FAR) of 1.5 and no additional parking is required. The applicant believes that no load-in and load-out zones are required for the Private Event Facility, and the applicant has taken steps to minimizing the need for this with a 1,180 square foot on-site storage room. The applicant has argued that they intend to comply with the regulations for deliveries along Main Street, as provided in [Municipal Code 9-8-3](#). Finally, they argue that sufficient emergency vehicle access has been provided.

### ***Staff's Response***

Staff contracted with Hales Engineering to conduct a Traffic Study on the proposed Private Event Facility with data provided from the Park City Public Works Department (see Exhibit F). Their recommendation included creating a 15-minute loading/unloading zone in front of the Kimball along Heber Avenue to be shared by TNCs delivering visitors to Main Street (and not specifically reserved for the Kimball). They also recommended extending the red curb to ensure sufficient space

for emergency vehicles. Hales Engineering found that China Bridge would be able to support the parking generated by a 480-person event about 72% of the time, recognizing that the highest traffic volumes occur during January and July and that the lowest traffic volumes occur in April and May. They recommended limiting the size of events at the Private Event Facility based on the time of year due to seasonal traffic volumes and available parking. They also suggested that Event Center Staff create a plan to clearly instruct guests of the location of the venue, where to park, and how to use the loading zone.

Staff does not believe that the applicant can or should rely solely on parking in China Bridge to meet the parking demands of all their events. Further, staff finds that while the additional traffic may not impact existing traffic demands on Highway 224 or Kearns Boulevard, it will likely impact traffic in the downtown core, specifically along Park Avenue, Heber Avenue, and Main Street. For these reasons, staff has proposed the Conditions of Approval outlined below.

Consistency with other CUPs for similar uses:

Staff has also researched the CUP approvals for similar spaces that regularly hold events. Harry O's CUP for the Private Club required a parking management plan to "identify parking activities and alternatives to parking." The other uses did not include Conditions of Approval to address parking.

Based on the Hales Engineering Traffic Study and further research, staff is recommending the following additional Conditions of Approval. The applicant has consented to these conditions:

*#16. Guests and patrons using the Private Event Facility shall abide by the same parking and access restrictions as other visitors to Main Street.*

*#17. Prior to the activity, notification must be given to guests, event workers, and any additional persons that will be in attendance that additional parking may not be available within the Main Street Core.*

*#18. No aspect of the activity may cause an obstruction of the pedestrian flow on the sidewalks.*

*#19. No aspect of the activity may cause an obstruction of the vehicular traffic. This includes, but is not limited to having pick-ups or drop-offs for people, furniture, or any other supplies.*

*#20. The applicant shall be responsible for the painting of the striped loading zone in front of the Kimball; however, the City will be responsible for its maintenance. A sign shall be installed by the City permitting this loading zone to be shared parking for all Main Street businesses; it will not be for the exclusive use of the Kimball.*

### 3. OPERATIONS MANAGEMENT

As staff met to discuss this proposed use with other City Departments, other concerns arose regarding safety and emergency management. To address these, staff has worked with the applicant to develop the following Conditions of Approval:

*#21. No tents, including temporary winter balcony enclosures, shall be permitted on the rooftop terrace at any time. except through the Special Event license, Master Festival License, or as approved by an Administrative CUP.*

*#22. The use of umbrellas, portable heaters, and similar improvements may be used during an event; however, they shall not be permanently stored on the rooftop terrace or visible from the public right-of-way except when in use during the private event.*

*#23. The applicant, at its cost, shall incorporate such measures to ensure that any safety, health, or sanitation equipment, and services or facilities reasonably necessary to ensure that the events will be conducted with due regard for safety are provided and paid for by the applicant.*

*#24. The applicant shall develop an Emergency Management Plan to be reviewed by the Fire Marshall and/or Emergency Manager. Special emphasis should be given to events occurring at the same time as community-wide events along Main Street.*

### 4. ADDITIONAL REVIEWS

Additionally, staff recognizes that there may be unforeseen issues that will require further mitigation once the Private Event Space is in use. In the past, CUPs have been approved for similar uses with the Condition of Approval that the Planning Department and/or the Planning Commission re-review the CUP one year after the CUP has been issued or if the City receives more than three (3) complaints about the use. Staff recommends the following Conditions of Approval, which the applicant has consented to, in order to ensure that this CUP functions similarly:

*#25. In the event that sustained complaints are registered with the City regarding this use, including complaints of glare, noise, smoke, odor, grease, or traffic, the applicant will be required to provide mitigation of the complaint within 30 days. The Planning Department shall investigate these complaints and take measures necessary to ensure that the property owner complies with the requirements of this permit. Additionally, the Planning Department may bring forward these complaints to the Planning Commission, as deemed necessary by the Planning Director, in order to further mitigate the nuisance. Should the nuisance not be mitigated, the Planning Commission may revoke the conditional use permit.*

*#26. Any time within a 12-month period after the first annual review, should the City receive more than three (3) sustained violations, the CUP shall come back to the Planning Commission to determine whether the CUP shall be revoked or additional conditions of approval should be added.*

*#27. Any violation of any city ordinance or pertinent code may result in criminal action and/or a civil action in accordance with the Park City Administrative Code Enforcement Program. (This process may include a revocation of any business license, CUP, or other city approval, after a hearing in accordance with the applicable ordinance or if none is provided, a show cause hearing before the Planning Commission.)*

*#28. Following the first 6 months of operations, Staff shall meet with the applicant to discuss the operations and report to the Planning Commission at a regular meeting.*

*#29. Following the first 1 year of operations, Staff shall meet with the applicant to discuss the operations and report to the Planning Commission at a regular meeting.*

### **Department Review**

This project has gone through an interdepartmental review. Specifically, this staff report has been reviewed by the Planning, Engineering, Building, Police, Public Works, Emergency Management, and Legal Departments. No further issues were brought up that have not been addressed by this report.

### **Notice**

Legal notice was published in the Park Record on September 26, 2018, according to requirements of the Land Management Code. A property notice and mailing was also completed on September 22, 2018.

### **Public Input**

All public comment provided prior to the publishing of this report has been posted [online](#). Past public comment has been provided as exhibits to previous staff reports.

### **Recommendation**

Staff recommends that the Planning Commission discuss the remand of the appeal of the Conditional Use Permit (CUP) for a Private Event Facility at the Historic Kimball Garage at 638 Park Avenue, hold a public hearing, and consider approving the CUP for the Private Event Facility.

### **Exhibits**

Exhibit A – City Council Remand Letter, 4.14.17  
Exhibit B – Planning Commission Action Letter, 12.16.16  
Exhibit C – BNA Consulting Acoustical Study  
Exhibit D – Staff’s Acoustical Study, conducted 9.19.2018  
Exhibit E– Staff’s analysis of CUPs for similar uses  
Exhibit F – Hales Engineering Traffic Study  
Exhibit G – [Public Comment](#)

### **Finding of Fact:**

1. The subject property is located 638 Park Avenue. It is also Lot 1 of the Kimball on Main plat amendment that was recorded on February 3, 2017.
2. The property is located in the Historic Recreation Commercial (HRC) District.
3. Per 15-2.5-10, the property is also located in the Heber Avenue Subzone; the allowed uses within the sub-zone are identical to the allowed uses of the Historic Commercial Business (HCB) District, and the conditional uses within the sub-zone are identical to the conditional uses in the HCB District. A private event facility is a conditional use in the HCB zoning district.
4. The property is bound by Main Street to the east, Heber Avenue to the south, and Park Avenue to the west. These are all public streets.
5. The Park City Council approved the Kimball on Main Plat Amendment for this property at 638 Park Avenue on May 19, 2016. The plat was recorded on February 2, 2017 with the Summit County Recorder.
6. The site is designated as Landmark on the City's Historic Sites Inventory (HSI).
7. The Historic District Design Review (HDDR) for the new development was approved on June 20, 2016. Based on this approval, the applicant rehabilitated the historic Kimball Garage and constructed a new addition to the east, fronting Main Street.
8. The Park City Museum and Historical Society submitted an appeal of the HDDR on June 30, 2016. The Board of Adjustment met on October 18, 2016, denied the appeal, and upheld staff's determination. The BOA recommended that the Planning Department and the applicant propose rules to regulate the rooftop deck and prevent umbrellas, tents, and other temporary structures from detracting from the invisibility of the deck.
9. The BOA found that the rooftop deck addition above the historic Kimball Garage was appropriate as the Design Guidelines permit construction of rooftop additions and the addition would remove one of the two barrel-vaulted roof forms. The addition was permissible because it was generally not visible from the primary public right-of-way along Heber Avenue.
10. In 1984, the Kimball Art Center had a Gross Floor Area of approximately 13,477 square feet, which generates an FAR of 0.7. The 0.7 FAR is less than the 1.5 FAR that they paid for as part of the Main Street Parking Special Improvement District.
11. Gross Commercial Floor Area includes all enclosed Areas of the building, but excludes parking areas. Unenclosed porches, Balconies, patios and decks, vent shafts and courts are not calculated in Gross Commercial Floor Area. Areas below Final Grade used for commercial purposes including, but not limited to, storage, bathrooms, and meeting space, are considered Floor Area.
12. On March 20, 2016, the Planning Director found that the Kimball Art Center was current in their assessment to the Main Street Parking Special Improvement District as of January 1, 1984, for parking requirements up to a Floor Area Ratio (FAR) of 1.5. In 1984, the Kimball Art Center was located in the Historic Commercial Business (HCB) District; however, the zone changed in 2006 to Historic Recreation Commercial (HRC). The proposed FAR of the proposed project with the new addition is 1.45.
13. In 1984, the Kimball Art Center had a Gross Floor Area of approximately 13,477 square feet, or an FAR of 0.7. The 0.7 FAR is less than the 1.5 FAR that the

applicant's predecessor in title paid for as part of the Main Street Parking Special Improvement District.

14. There is no vehicular access proposed. Delivery, loading, and unloading zones for the Private Event Facility will be limited to Heber Avenue, or as may otherwise be provided in a special event permit issued by the City in accordance with applicable rules.
15. Because 638 Park Avenue is located in the Heber Avenue Subzone, the FAR limitation of the HRC District does not apply to gross commercial floor area; however, the parking exception is only for an FAR up to 1.5.
16. The Conditional Use Permit (CUP) for the Private Event Facility requires that all developments are subject to the conditions and requirements of the conditional use review of LMC chapter 15-1-10.
17. The Planning Commission held public hearings for the CUP application on November 9, 2016, and December 14, 2016. On December 14, 2016, the Planning Commission reviewed the CUP application and approved the Private Event Facility as a conditional use subject to the conditions proposed by the Planning Commission and staff. The Planning Commission unanimously approved the CUP application with a 6-0 vote.
18. The Planning Commission approval of the CUP was appealed to the City Council on December 22, 2016.
19. On March 30, 2017, the Park City Council reviewed the appeal and concluded that certain mitigation elements were not sufficient. The City Council remanded the appeal back to the Planning Commission for further review. The City Council was overall not in favor of the proposed CUP as they believed that there were reasonably anticipated detrimental effects of the proposed CUP that could not be substantially mitigated. These impacts included:
  - a. The location of the site faced uphill residential neighborhoods and additional Conditions of Approval would be needed to adequately address noise associated with the outdoor event space. There were concerns that the geographic location of the site prevented the mitigation of noise impacts altogether.
  - b. The glass railings and walls would be sound reflectors and amplify the noise.
  - c. Concerns that event uses, hours, and operations would become a nuisance to the surrounding residential neighborhood.
  - d. Fears that the Private Event Facility use would exasperate the already congested intersections of Main Street and Heber Avenue as well as Park Avenue and Heber Avenue due to increased traffic, loading/unloading, and additional parking demands generated by the use. They did not want to see overflow parking on Park Avenue that would create additional duress for the residential neighborhood.
  - e. Found that the use was compatible with some, but not all of the neighbors, specifically the surrounding and adjacent residential areas that abut the Heber Avenue Subzone.
  - f. Believed allowing tents on the outdoor terrace was counterintuitive to the BOA's finds that outdoor furnishings, heaters, and other visual obstructions be limited on the deck space.

20. On September 27, 2017, the Planning Commission reviewed the applicant's proposed mitigation strategies during work session. The Planning Commission expressed concerns about:
- a. Wanted to limit the use of the outdoor terrace to daylight hours only and refrain from heating the space after dark.
  - b. Found the proposed vestibule between the indoor and outdoor event spaces would mitigate sound, but wanted additional analysis to ensure that the glass railings would not act as a speaker and amplify noise.
  - c. Requested further demonstration on how amplified noises would be regulated by the proposed technology. There were also concerns about the noise monitoring equipment not being able to mitigate the sound of guests having a conversation on the deck.
  - d. The additional traffic generated by this use would block bus traffic and requested the applicant provide a viable plan for mitigating the traffic.
  - e. The applicant had not adequately addressed loading/unloading areas. In addition to blocking sidewalk traffic, there were concerns that large crowds departing the event space at the same time would increase noise levels.
  - f. The additional parking generated by this use would rely on China Bridge, which was designed for shared parking not intensive private events.
  - g. It was not appropriate for the applicant to perpetually rely on purchasing parking spaces from the City to address parking generated by the events. The Planning Commission was also not supportive of reducing parking or permanently converting parking along Heber Avenue into a 15-minute loading/unloading zone.
  - h. The outdoor dining associated with neighboring restaurants had a much lower occupancy load than the proposed outdoor terrace of the Private Event Facility. Planning Commission requested the applicant to provide occupancy loads for the interior and exterior spaces.
  - i. Believed there would be fewer concerns with the use if the applicant was willing to limit the types of events, hours of operation, and duration of events on the site.
  - j. Requested that Conditions of Approval defining the location and duration of any tents on the outdoor event space be maintained.
21. On May 11, 2018, the applicant submitted a narrative describing the ways in which they believed they have mitigated the impacts of the Private Event Facility by:
- a. Commissioning Henderson Engineers to conduct a third-party study of noise. The consultants found that ambient noise averaged about 52.5 dBA. Based on an analysis of 150 guests with 2 acoustic musicians on the terrace and 75 people talking simultaneously, the study found the maximum noise level would be 72 dBA for "loud talking". Applicant believes that the average sound levels will vary between 60 dBA to 65 dBA depending on the time of day for outdoor events, which complies with the City's Noise Ordinance standards of 60 dBA from 10pm to 6am and 65 dBA from 6am to 10pm.
  - b. Introducing design features such as a sound trap in the soffit of the west elevation, acoustic baffles in the ventilation outlets, insulated glass doors and windows, a vestibule between the interior and exterior event spaces,

- automatic closing devices on the exterior doors, and landscape buffers on the south and west sides of the terrace to mitigate noise. The applicant also argues that the glass railings will actually reflect the noise back into the terrace and not outwards towards the uphill residential neighborhoods.
- c. Proposing a Noise Mitigation Plan as part of their operations management that provide for sound limiting and monitoring equipment, training procedures for event staff, and robust complaint procedures. Additional procedures will disallow the removal of containers (garbage) and emptying of bottles to external areas after 9pm.
  - d. Providing parking up to an FAR of 1.5, thus no additional parking is required.
  - e. Providing on-site storage to further mitigate the need for loading/unloading of deliveries associated with the Private Event Facility. Applicant has stated they will follow the regulations for delivery along Main Street as provided in Municipal Code 9-8-3.
  - f. Applicant believes the use is consistent with the General Plan, which encourages the use of Old Town as a backdrop for events. Applicant further argues that the HRC Heber Avenue Subzone is intended to provide a transition in scale and land Uses between the HR-1 and HCB zoning district. Applicant contests that they have mitigated the impacts of the use by locating the entrance to the space along Heber Avenue, addressing noise, and mitigating impacts of parking, loading/unloading, and traffic.
  - g. Applicant has committed to requesting an Administrative Conditional Use Permit for any proposed tents to be temporarily installed on the rooftop terrace.
22. On June 13, 2018, the Planning Commission reviewed the CUP remand once more, continued the item to a date uncertain, and directed the applicant to continue to work with staff on developing Conditions of Approval. The Planning Commission also directed staff to commission a third party review of the Henderson Noise Study as well as a traffic study.
  23. On August 8, 2018, the Planning Commission conducted a site visit to the proposed Private Event Space at 638 Park Avenue.
  24. The applicant has modified and supplemented its application, submitted information and data from experts, including acoustical professionals, and cooperated with the City staff to verify the results of the applicant's studies.
  25. The additional City Council and Planning Commission meetings and input have resulted in modifications to the proposed conditions and requirements for the operation of the facility.
  26. The City contracted BNA Consulting to conduct an acoustical study that was completed in September 2018. The sound levels from traffic and construction noise largely masked any sounds made by people on the rooftop deck. The acoustical engineer confirmed the findings of the Henderson Report in that the amount of noise generated by guests and musicians on the rooftop deck would not exceed the City's Noise Ordinance. He found that noise levels could exceed the City's Noise Ordinance on cold nights when there was snow on the ground as these conditions would carry the sound more quickly over longer distances.

27. The Planning, Building, and Police Departments also conducted a sound study on Tuesday, September 18<sup>th</sup> at 9pm. The purpose of staff's acoustical analysis was to create conditions reflective of an average event activity (music playing during the evening at cooler temperatures). Staff found that the amount of sound dissipation over distance created a situation within which activities could be hosted and maintained on the terrace and could comply with the noise ordinance. Staff concluded that sound pressure levels on the terrace of 90dBA, which is permitted under Municipal Code 6-3-11 Relief from Restrictions, would likely be inappropriate; 90dBA is typically the exception that is granted for Special Events such as Silly Sunday Market.
28. The City contracted with Hales Engineering to conduct a Traffic Study for this use, utilizing parking data provided by the Park City Public Works Department. They recommended creating a 15-minute loading/unloading zone in front of the Kimball along Heber Avenue, as well as extending the red curb to ensure sufficient space for emergency vehicles. Hales Engineering found that China Bridge would be able to support the parking generated by a 480-person event about 72% of the time, recognizing that the highest traffic volumes occur during January and July and that the lowest traffic volumes occur in April and May. They recommended limiting the size of events at the Private Event Facility based on the time of year due to seasonal traffic volumes and available parking. They also suggested that Event Center Staff create a plan to clearly instruct guests and employees of the location of the venue, where to park, and how to use the loading zone.
29. The event space is intended to be privately owned and professionally managed. The applicant anticipates that the number of employees will vary from 4 to 40 based on the type of event. The applicant anticipates events no larger than an occupancy load of 480.
30. Use of the outdoor rooftop terrace is permitted by this Conditional Use Permit and all such use shall comply with all conditions and regulations included herein.
31. The Applicant has agreed not to locate or use tents on the balcony, unless authorized by a Special Event Permit separately issued by the City.
32. The applicant anticipates that hours of use will vary depending on the event; however, typical operating hours will be between 8am and Midnight for the interior space. Programmed outdoor events will be limited to 11am to 10pm and all uses must comply with the City's Noise Ordinance.
33. The applicant has prepared a Noise Management Plan. At each event, the applicant shall have on site staff trained to enforce the Noise Management Plan. If there is a noise ordinance complaint associated with the use of the outdoor balcony, City staff can require a meeting to review compliance with ordinances and to review potential revisions to the Noise Management Plan.
34. The applicant has commissioned a professional noise study of the activities contemplated for the site. The noise study confirms that normal operations and use of the outdoor balcony will not violate the City's noise ordinance. In particular, the noise study shows that 150 guests with musicians on the terrace with each guest engaged in "loud talking" would not violate the noise ordinance. To provide additional security that the noise ordinance will not be violated, applicant has proposed conditions for the use of the outdoor balcony which are detailed below.

35. The outdoor balcony has a maximum occupant load of 141 occupants. Applicant shall monitor the occupant load at each event for fire code compliance and also to facilitate further mitigation of the risk of a noise ordinance violation.
36. The applicant has committed that for events ending after 9 pm, loading of equipment and refuse on Heber Avenue will occur the next morning, and not after the event, in order to further mitigate any noise associated with an event.
37. Based on information from the noise study, applicant has also added design features into the building, its windows and doors, and outdoor balcony to minimize noise transfer and to create a “sound trap” in the outdoor soffit. Applicant has voluntarily incorporated these design elements even though no code or zoning regulation requires these elements.
38. The proposal **complies** with LMC 15-1-10(D) in that the Planning Commission found that the CUP complies with all of the requirements of the LMC; that the use is compatible with surrounding Structures in Use, scale, mass and circulation; and that the effects of any differences in Use or scale have been mitigated through careful planning. The applicant’s occupancy loads are 480 occupants for the entire space, with the outdoor event space limited to 141 occupants, based on un-concentrated assembly use on the outdoor event space; this is a 27.8% reduction in the allowable occupancy based on building codes. The occupancy of the proposed rooftop terrace is significantly larger than similar outdoor dining space in the HCB and HRC zoning district. The applicant has sufficiently addressed limiting the types of events, hours of operation, and duration of events at the site. The applicant has adequately addressed traffic mitigation, off-site parking, and loading/unloading. Emergency management has not been addressed.
39. The proposal **complies** with LMC 15-1-10(E)(12) in that noise, vibration, odors, steam, and other mechanical factors that might affect people and Property Off-Site have been mitigated through the Conditions of Approval of the CUP approved on December 14, 2016. The applicant has mitigated the impacts for potential amplified music and sound on the balcony through the use of design elements and technology. The applicant has also provided a means of controlling the non-amplified noise that is caused by a talking crowd through design elements. Further, the applicant has reduced the hours of operation and occupancy load on the rooftop terrace in order to further limited noise.
40. The proposal complies with LMC 15-1-10(E)(10) in that exterior lighting has been mitigated through the Conditions of Approval of the CUP approved on December 14, 2016. All exterior lighting will be in compliance with the Park City codes and the Design Guidelines for Historic Districts and Historic Sites, which requires that lighting fixtures be downward directed and shielded.
41. The proposal **complies** with LMC 15-1-10(E)(2) in that traffic considerations including capacity of the existing streets in the area; LMC 15-1-10(E)(4) Emergency Vehicle Access; and LMC 15-1-10(E)(13) control of delivery and service vehicles, loading and unloading zones, and screening of trash and recycling pick-up Areas. The Planning Commission has found that the current owner will be reducing the overall size of the event space and the new event space will generate new and additional traffic to the site. Guests and patrons of the Private Event Space will have to abide by the same parking and access restrictions as other visitors to Main Street.

The applicant has met the minimum requirements for parking and loading/unloading as outlined in the Municipal Code and LMC. The applicant will provide traffic and parking mitigation and emergency management plans for when the proposed private events coincide with large-scale community events.

42. The proposal **complies** with LMC 15-1-10(E)(5) Location and amount of off-street parking. The Planning Director found that the Kimball Art Center was current in their assessment to the Main Street Parking Improvement District as of January 1, 1984, for a parking requirement up to an FAR of 1.5. The applicant is proposing a total FAR of 1.45 following completion of the new addition, and is not required to provide on-site parking. Exterior spaces, such as the rooftop terrace, are not included in the FAR calculation. The applicant has sufficiently addressed the impacts of spikes in traffic and parking demands generated by the private event space, and they have demonstrated that any loading/unloading of guests attending private events will not add to the already congested intersections of Park Avenue-Heber Avenue and Main Street-Heber Avenue. They have also demonstrated that loading/unloading will not impede bus traffic and circulation.
43. The proposal complies with LMC 15-1-10(D)(1) in that the application complies with all requirements of the LMC, including the Design Guidelines. The BOA reviewed the Park City Museum's appeal of the HDDR and upheld staff's determination that the HDDR complied with the Design Guidelines.
44. The applicant has consented to applying for separate Administrative Conditional Use Permits (Admin-CUPs) for any temporary tent(s) installed on the rooftop terrace.
45. The rooftop outdoor event space **complies** with LMC 15-1-10(E)(16) Goals and Objectives of the Park City General Plan. The proposal contributes to maintaining the Historic Main Street District as the heart of the City for residents and encourages tourism in the district for visitors.
46. The proposed rooftop terrace is consistent with the Design Guidelines, as determined by the BOA during the October 18, 2016 appeal hearing.
47. The proposed Rooftop outdoor event facility is consistent with the Design Guidelines as determined by the BOA during the October 18, 2016 hearing.
48. The applicant has agreed to these Conditions of Approval.

### **Conclusions of Law**

1. The application is consistent with the Park City Land Management Code, particularly section 15-1-10, Conditional Use Permits.
2. There are changes in circumstance that result in mitigated impacts and result in findings of compliance with the Park City General Plan or Land Management Code.

### **Conditions of Approval**

1. All standard conditions of approval apply to this Conditional Use Permit.
2. Should the applicant propose to host an event in the Private Event Facility that goes beyond the Private Event Facility Use and the Conditions of Approval outlined in this CUP, a Special Event permit may be required.
3. This CUP does not include any events programmed for the site that may be reviewed on a case-by-case basis through the City Special Events licensing or Master Festival Special Event permitting or master festival license process.

4. All exterior mechanical equipment shall be painted and/or otherwise screened and shielded from public streets. All wall and roof top vents and protruding mechanical shall be painted to match the adjacent wall or roof and/or screened from public view.
5. A condominium plat must be recorded prior to the sale of any of the individual units.
6. All exterior lighting, including any existing lighting and lighting on the balcony and terrace, shall comply with the Lighting Requirements of LMC 15-5-5(I). The lighting shall be downward directed and fully shielded. Exterior lighting shall be approved by the Planning Department prior to installation.
7. The typical hours of operation of the interior portion of the space shall be limited to 8 am to midnight.
8. The rooftop terrace shall not be used for activities that may create dust or odor, such as but not limited to cooking.
9. Programmed activity and occupancy of all outdoor spaces shall cease at 10pm. The hours of operation of the rooftop terrace shall be limited to 11am to 10pm.
10. The owner shall orient the activities so as to minimize sound impacts to the neighborhoods and the applicant shall monitor the following:
  - a. The owner, or his/her designee, shall provide on-site management for each aspect of the event.
  - b. The owner shall be responsible to ensure that the sound system maintains level adjustments not to exceed provisions of the Park City Noise Ordinance for the outdoor use.
  - c. The owner shall install noise limiting equipment in all areas where events will take place. This equipment is linked into the electrical supply which feeds the music systems and will cut the supply if a dBA reading exceeds the threshold levels of music noise with the City noise ordinance. The equipment works on a traffic light sequence and will be visible to performers, guests and event staff. The red banding will only be tolerated for a three seconds before the system shuts down automatically.
  - d. Owner shall not allow the use of music on the outdoor balcony after 10 pm, shall limit occupancy on the outdoor balcony to no more than 141 occupants, and shall operate the facility in accordance with the Noise Management Plan.
  - e. For events ending after 9 pm, loading of off-site equipment and trash on Heber Avenue shall occur the next morning, not the night of the event. Clean-up for the rooftop terrace shall remain subject to the Noise Ordinance following the programmed event.
  - f. The operator shall be required to maintain a copy of the Conditions of Approval of this CUP onsite should the Police Department request them.
11. The owner shall not permit or provide either live or recorded amplified music within the interior of the space without first having closed all exterior doors and windows of the licensed premise. Doors may be opened to provide ingress and egress, but shall not be blocked in the open position to provide ventilation. Doors shall be equipped with automatic closing devices to keep them in the closed position except to permit ingress and egress of patrons.
12. No elevated stages or elevated free-standing speakers exceeding the height of the glass railing for performances shall be allowed on the outdoor spaces of the event center.

13. Outdoor speakers shall not cause to exist any loud speaker or sound amplification equipment on the outdoor balcony or rooftop terrace associated with the licensed premises other than speaker systems or sound amplification equipment in conjunction with approved outdoor dining. Music is limited from 11 am to 10 pm and may not carry beyond the boundaries of the rooftop terrace or balcony as regulated by the Noise Ordinance.
14. In accordance with Park City Municipal Code 6-3-9, as may be amended, any violation shall be measured at a distance of at least twenty-five feet (25') from the source of the device upon public property or within the public right-of-way or twenty-five feet (25') from the property line if upon private property, and shall be measured on a decibel or sound level meter of standard design and quality operated on the "A" weighting scale. A measurement of 65 decibels shall be considered to be excessive and unusually loud.
15. The operator shall provide advanced written notification to the Park City Planning Department of each event they plan to hold with an occupancy load of 250 or more. The operational description shall be submitted at least two (2) weeks (ten business days) before any event for review and approval of mitigation strategies, not to be unreasonably withheld, by the Chief Building Official, Transportation, Engineering, and Planning Departments. Event operator contact information shall be provided to the Park City Police Department for contact in case of violations. Additionally, the applicant should provide:
  - a. An Event Management Plan shall be prepared and reviewed by the Planning, Building, Engineering, and Police Departments for each event with an occupancy load of 250 or more. The Event Management Plan shall include provisions for ticket sales (if applicable); health and safety; participant behavior and control; security; parking; transportation; and traffic. Security shall be provided for events over 250 occupants, on a ratio of 1 security personnel per 50 guests unless otherwise approved by the Park City Police Department.
  - b. A Traffic Management Plan shall be prepared to identify traffic flow, traffic control (if applicable), as well as parking activities and alternatives to parking for all events with occupancy loads of 250 or greater. The plan shall address private shuttle service, enforcement of drop-off and loading zones, stewards directing parking patrons to correct locations, and other mitigation strategies.
  - c. The City reserves the right to request additional mitigation strategies for events exceeding 250 occupants should the City find that the applicant has not adequately mitigated the impacts of said event.
16. Guests and patrons using the Private Event Facility shall abide by the same parking and access restrictions as other visitors to Main Street.
17. Prior to the activity, notification must be given to guests, event workers, and any additional persons that will be in attendance that additional parking may not be available within the Main Street Core.
18. No aspect of the activity may cause an obstruction of the pedestrian flow on the sidewalks.

19. No aspect of the activity may cause an obstruction of the vehicular traffic. This includes, but is not limited to having pick-ups or drop-offs for people, furniture, or any other supplies.
20. The applicant shall be responsible for the painting of the stripped loading zone in front of the Kimball; however, the City will be responsible for its maintenance. A sign shall be installed by the City permitting this loading zone to be shared parking for all Main Street businesses; it will not be for the exclusive use of the Kimball.
21. No tents, including temporary winter balcony enclosures, shall be permitted on the rooftop terrace at any time. except through the Special Event license, Master Festival License, or as approved by an Administrative CUP.
22. The use of umbrellas, portable heaters, and similar improvements may be used during an event; however, they shall not be permanently stored on the rooftop terrace or visible from the public right-of-way except when in use during the private event.
23. The applicant, at its cost, shall incorporate such measures to ensure that any safety, health, or sanitation equipment, and services or facilities reasonably necessary to ensure that the events will be conducted with due regard for safety are provided and paid for by the applicant.
24. The applicant shall develop an Emergency Management Plan to be reviewed by the Fire Marshall and/or Emergency Manager. Special emphasis should be given to events occurring at the same time as community-wide events along Main Street.
25. In the event that sustained complaints are registered with the City regarding this use, including complaints of glare, noise, smoke, odor, grease, or traffic, the applicant will be required to provide mitigation of the complaint within 30 days. The Planning Department shall investigate these complaints and take measures necessary to ensure that the property owner complies with the requirements of this permit. Additionally, the Planning Department may bring forward these complaints to the Planning Commission, as deemed necessary by the Planning Director, in order to further mitigate the nuisance. Should the nuisance not be mitigated, the Planning Commission may revoke the conditional use permit.
26. Any time within 12 month period after the first annual review, should the City receive more than three (3) sustained violations, the CUP shall come back to the Planning Commission to determine whether the CUP shall be revoked or additional conditions of approval should be added.
27. Any violation of any city ordinance or pertinent code may result in criminal action and/or a civil action in accordance with the Park City Administrative Code Enforcement Program. (This process may include a revocation of any business license, CUP, or other city approval, after a hearing in accordance with the applicable ordinance or if none is provided, a show cause hearing before the Planning Commission.)
28. Following the first 6 months of operations, Staff shall meet with the applicant to discuss the operations and report to the Planning Commission at a regular meeting.
29. Following the first 1 year of operations, Staff shall meet with the applicant to discuss the operations and report to the Planning Commission at a regular meeting.

**ACTION LETTER**

**Subject:** Remand from City Council to the Planning Commission on the Appeal of a Private Events Facility at 638 Park Avenue (Historic Kimball Garage)

**Project#:** PL-16-03412

**Date:** April 14, 2017

**Type of Item:** Remand of a Quasi-Judicial Appeal of Planning Commission's approval of a Conditional Use Permit (CUP) for a Private Events Facility

On March 30, 2017, the City Council held a public hearing and considered a Quasi-Judicial Appeal of Planning Commission's approval of a Conditional Use Permit (CUP) for a Private Events Facility at 638 Park Avenue and hereby REMANDS the CUP and the use as proposed/configured back to the Planning Commission with specific direction as outlined below:

1. The Conditional Use Permit (CUP) for the Private Event Facility requires that the use is subject to the conditions and requirements of the conditional use review of LMC chapter 15-1-10.
2. The City Council reviewed the appeal of the CUP for a Private Events Facility at 638 Park Avenue (historic Kimball Garage) on March 30, 2017.
3. During the City Council review of the appeal of the proposed use, Council found that impacts from the noise from the outdoor terrace on the second level of the historic Kimball building was not mitigated.
4. Council found that the impacts of the proposed use as configured related to amplified outdoor music and human chatter could violate the City's Noise Ordinance.
5. Council found that the glass railings and open space on the deck would amplify the noise and create noise impacts on the roof deck which cannot be mitigated.
6. City Council found that impacts from the proposed use as configured related to traffic had not been mitigated. They found it impacts included likely bottlenecking on the corners of Heber Avenue and Main Street as well as Heber Avenue and Park Avenue, particularly during peak load-in and load-out times.
7. Council found that the impacts of the use would increase parking demand which has not been mitigated.
8. City Council found that unmitigated impacts included the lack of a load-in and load-out zone or a clear traffic mitigation plan for events.
9. City Council found that the use of the second level roof deck as Private Event Space as proposed was not mitigated to be compatible with the surrounding residential uses to the north and west of the site.
10. City Council found that the use of the proposed roof deck on the second level was too unrestricted and not compatible in use to neighboring structures as currently proposed. They found it was very visible due to its geographic location at the bottom of the street and it was too public and too impactful to the surrounding neighborhood as currently proposed.

11. City Council found that the proposed tent to be located on the northwest corner of the roof deck conflicted with the BOA's findings that activities on the deck should be visually minimized. Council found that a mitigation could be to require any tents to be reviewed and approved through a special events permit.
12. At a minimum, Council suggested the impacts could be mitigated by a limitation on the number of days and times the roof deck and tent would be in use.
13. City Council found that a mitigation of the impacts could include on going monitoring with the Planning Commission to ensure the applicant was complying with the conditions of approval of the CUP.
14. City Council found that mitigations of the impacts included reducing the visibility of the roof deck which was required by the Board of Adjustment.
15. The City Council found the proposed use and configuration failed to mitigate the impacts in reviewing the criteria listed in LMC § 15-1-10(E)(2), (4), (5), (6), (7), (10) (11), (12), (13) and (16) by failing to mitigate the traffic considerations including capacity of the existing streets in the Area; emergency vehicle Access; location and amount of off-street parking; internal vehicular circulation system; Fencing, Screening, and landscaping to separate the Use from adjoining Uses; signs and lighting; physical design and Compatibility with surrounding Structures in mass, scale, style, design, and architectural detailing, noise vibration, odors, steam, or other mechanical factors that might affect people and Property Off-Site; control of delivery and service vehicles, loading and unloading zones, and pickup areas and within and adjoining the Site, Environmentally Sensitive Lands, Physical Mine Hazards, Historic Mine Waste and Park City Soils Ordinance, Steep Slopes, and appropriateness of the proposed Structure to the existing topography of the Site;.
16. Council remanded the appeal for further review of the Indoor use related to the private event facility and required additional mitigation evaluation by the Planning Commission on loading areas, traffic and parking
17. Council remanded the CUP for further review by the Planning Commission to mitigate the impacts of the Outdoor deck use. As proposed the impacts are not adequately mitigated. Review of the impacts and their mitigation should include at a minimum a strong re-evaluation of the design, and conditions of approval which reflect the requirements of the Board of Adjustment decision including minimum visual impacts on the roof.
18. Council remanded the CUP for further review by the Planning Commission to mitigate the impacts specific to the overall use purposed of traffic from deliveries including loading and unloading for deliveries and load in/load out areas
19. Council remanded the CUP for further review by the Planning Commission to mitigate the impacts specific to the overall use purposed of traffic patron use including loading and unloading and pick up and load in/load out areas
20. Council remanded the CUP for further review by the Planning Commission to mitigate the impacts of Sound and Noise created by the use of the outdoor space The impacts of the sound needs to be mitigated by keeping the sound inside of the space so it doesn't unduly impact neighbors.
21. Council remanded the CUP for further review by the Planning Commission to mitigate the impacts of the Outdoor space on the compatibility of the

neighborhood. Such mitigation may include denial of use of the deck beyond which is already permitted, limit number of people on the deck, limiting the use of the deck for the conditional use. Council asked Planning Commission to focus on implementing strong mitigation for impacts of use of outdoor deck including compatibility, noise mitigation concerns and impacts beyond ancillary deck use which is permitted. Mitigation should limit any noise any mitigation use beyond permitted use on the deck and consider mitigation including design changes, limitation or reduction of use by hours per days or number of days, direction of deck/event space, remove speakers, require sound insulation between indoor use and outdoor use (i.e don't permit glass separation)

- 22. Council asked Planning commission to review impacts related to criteria 2, 5, 6, 12, and 13 closely.
- 23. Council remanded the CUP for the Planning Commission to consider mitigating impacts by having an affirmative review by the City incrementally by the use, more frequently than just once a year.
- 24. Council asked Planning commission to review impacts related to criteria 3 and 4 address loading traffic and parking. More specific conditions are needed to mitigate current impacts.
- 25. Council asked Planning commission to review impacts related to Noise. Council is unable to find a way to mitigation for noise and asked Planning Commission to revisit criteria 2,5,6,12,13 and 15 to find a better way to mitigate or to restrict the use to limit the noise through more restrictive event usage or limited hours.
- 26. Council asked Planning commission to review impacts related to the visual impacts and found Condition of Approval 11 of the Planning Commission determination contradicts Board of Adjustment findings and impacts need to be mitigated related to tents and other rooftop visual impacts
- 27. Council asked Planning commission to review impacts of Condition of Approval 15 of the Planning Commission determination and consider an additional review component.

Remanded March 30, 2017

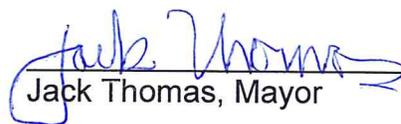
  
 Jack Thomas, Mayor

Attest:

  
 City Recorder's Office

Approved as to form:

  
 City Attorney's Office



# Exhibit B



December 16, 2016

Tony Tyler  
CPP Kimball LLC  
C/O: Columbus Pacific Properties  
429 Santa Monica Blvd. Ste. 600  
Santa Monica, CA 90401

## NOTICE OF PLANNING COMMISSION ACTION

<u>Application #</u>	PL-16-03313
<u>Subject</u>	638 Park Avenue/Historic Kimball Garage
<u>Address</u>	638 Park Avenue
<u>Description</u>	Conditional Use Permit for Private Event Facility and Tent
<u>Action Taken</u>	Approved
<u>Date of Action</u>	December 14, 2016

On December 14, 2016, the Planning Commission called a meeting to order, a quorum was established, a public meeting was held, and the Planning Commission approved the proposed Private Event Facility and Tent at 638 Park Avenue based on the following:

### **Findings of Fact**

1. The Condition Use Permit is for a private event facility at 638 Park Avenue .
2. The property is located in the Historic Recreation Commercial (HRC) District).
3. Per 15-2.5-10he property is located in the Heber Avenue Subzone; the allowed uses within the sub-zone are identical to the allowed uses of the Historic Commercial Business (HCB) District, and the Conditional Uses within the sub-zone are identical to the Conditional Uses in the HCB District.
4. The property is bound by Main Street to the east, Heber Avenue to the south, and Park Avenue to the west. These are all public streets.
5. The Park City Council also approved a Kimball on Main plat amendment for this property at 638 Park Avenue on May 19, 2016. The plat has not yet been recorded.
6. The site is designated as Landmark on the City's Historic Sites Inventory (HSI).
7. The Historic District Design Review (HDDR) for the new development was originally approved on June 20, 2016. The applicant is proposing to rehabilitate the historic Kimball Garage and construct a new addition to the east, fronting Main Street.

8. An appeal of the HDDR was submitted by the Park City Museum and Historical Society on June 30, 2016. The Board of Adjustment met on October 18, 2016, denied the appeal and upheld staff's determination. The BOA recommended that the Planning Department and the applicant propose rules to regulate the rooftop deck and prevent umbrellas, tents, and other temporary structures from detracting from the invisibility of the deck.
9. The BOA found that the rooftop deck addition above the historic Kimball Garage was appropriate as the Design Guidelines permit construction of rooftop additions and the addition would remove one of the two barrel-vaulted roof forms. The addition was permissible because it was generally not visible from the primary public right-of-way along Heber Avenue.
10. On March 20, 2016, the Planning Director found that the Kimball Art Center was current in their assessment to the Main Street Parking Special Improvement District as of January 1, 1984, for parking requirements up to a Floor Area Ratio (FAR) of 1.5. In 1984, the Kimball Art Center was located in the Historic Commercial Business (HCB) District; however, the zone changed in 2006 to Historic Recreation Commercial (HRC). The proposed FAR of the proposed project with the new addition is 1.45.
11. In 1984, the Kimball Art Center had a Gross Floor Area of approximately 13,477 square feet, which generates an FAR of 0.7. The 0.7 FAR is less than the 1.5 FAR that they paid for as part of the Main Street Parking Special Improvement District.
12. The minimum front/rear yard setbacks are ten feet (10'). The historic structure has a 1-foot front yard setback along Park Avenue and the new addition will have a 12-foot rear yard setback along Main Street.
13. Gross Commercial Floor Area includes all enclosed Areas of the building, but excludes parking areas. Unenclosed porches, Balconies, patios and decks, vent shafts and courts are not calculated in Gross Commercial Floor Area. Areas below Final Grade used for commercial purposes including, but not limited to, storage, bathrooms, and meeting space, are considered Floor Area.
14. Because 638 Park Avenue is located in the Heber Avenue Subzone, the FAR limitation of the HRC District does not apply to gross commercial floor area; however, the parking exception is only for an FAR up to 1.5.
15. The minimum side yard setbacks are five feet (5'); the historic structure currently has a side yard setback of 6 feet along the north property line. The new addition will have a 5-foot setback from the north property line.
16. On corner lots, such as this, the side yard setback that faces a street is ten feet (10'). The historic structure has a 1-foot side yard setback along Heber Avenue; the new addition will have a 10-foot setback along Heber Avenue.
17. Per LMC 15-2.5-4, a project may have only one vehicular Access from Park Avenue, Main Street, Heber Avenue, Swede Alley, or Deer Valley Drive, unless

an additional Access is approved by the Planning Commission. The applicant has provided vehicular access along Heber Avenue.

18. Per LMC 15-2.5-5, no structure, including a tent, shall be erected to a height greater than 32 feet from Existing Grade; the height of the roof on the new addition is a maximum of 30.5 feet.
19. Per LMC 15-2.5-5(A)(3), mechanical equipment and associated Screening, when enclosed or Screened, may extend up to five feet (5') above the height of the Building; the applicant is proposing parapets incorporated into the design of the street front facades in order to reduce the visibility of rooftop mechanical equipment. These parapets do not exceed 4.5 feet in height, for a maximum height of 35 feet above existing grade.
20. Per LMC 15-2.5-5(A)(5), an Elevator Penthouse may extend up to eight feet (8') above the Zone Height. The applicant has proposed an elevator penthouse on the northwest corner of the new addition. The height of the Elevator Penthouse does not exceed 38 feet in height from Existing Grade.
21. Per LMC 15-2.5-6, Historic Structures that do not comply with Building Setbacks, Off-Street parking, and driveway location standards are valid Non-Complying Structures.
22. Per LMC 15-2.5-8, all exterior mechanical equipment must be screened to minimize noise infiltration to adjoining Properties and to eliminate visual impacts on nearby Properties, including those Properties located above the roof tops of Structures in the HRC District. The applicant has proposed to locate mechanical equipment on the rooftop of the new addition, screening it with parapets and other rooftop screening.
23. Per LMC 15-2.5-9, all Development must provide an on-Site refuse collection and loading Area. Refuse and service Areas must be properly Screened and ventilated. Refuse collection Areas may not be located in the required Yards. The applicant has proposed an acceptable refuse storage area along the north property line, adjacent to Main Street.
24. On the third level of the new addition, the applicant is proposing a Private Event Facility. The Private Event Facility will include 3,785 square feet of interior space on the top floor above the street level commercial spaces as well as a 477 square foot outdoor balcony and 2,530 square foot rooftop terrace.
25. The LMC defines this as a facility where the primary Use is for staging, conducting, and holding Private Events. Private Events are events, gathering, party, or activity that is closed to the general public or that requires an invitation and/or fee to attend. A Private Event Facility is a Conditional Use in the Heber Avenue Sub-zone and is not permitted in storefronts along Heber, Park, and Main Street.
26. The Private Event Facility will be accessible from a street-level lobby along Heber Avenue. Access, circulation, and lobby areas are permitted within Storefront property.

27. In 2015, the Kimball hosted an event with an occupant load of 697 people. The applicant finds that the proposed Private Event Facility will have an occupancy load of 480 people, a 32% reduction from past event occupancy loads.
28. Special Events, as defined by the LMC, are those events, public or private, with either public or private venues, requiring City licensing beyond the scope of normal Business and/or liquor regulations or creates public impacts through any of the following: (A) Use of City personnel; (B) Impacts via disturbance to adjacent residents; (C) Traffic/parking; (D) Disruption of the normal routine of the community or affected neighborhood; or (E) Necessitates Special Event temporary beer or liquor licensing in conjunction with the public impacts, neighborhood block parties or other events requiring Street closure of any residential Street that is not necessary for the safe and efficient flow of traffic in Park City for a duration of less than one (1) day shall be considered a Special Event.
29. There is no vehicular access proposed. Delivery, loading, and unloading zones for the private event facility will be limited to Heber Avenue.
30. Outdoor use of the terraces and balconies are permitted by this CUP, and shall comply with all conditions and regulations included herein.
31. Any temporary structures, such as tents, are permitted by this CUP, and shall comply with all conditions and regulations included herein.
32. The Building Department will require a fire permit for the installation of any tent in excess of 400 square feet, measured from the outside dimensions.
33. The applicant anticipates that hours of use will vary depending on the event; however, typical operating hours will be between 8am and midnight. Outdoor speakers and music will be limited to 11am to 10pm in accordance with the City's Noise Ordinance.
34. There are no open space requirements specified for this development.
35. The design complies with the Park City Design Guidelines for Historic Districts and Sites and complements the mass, scale, style, design, and architectural detailing of its neighbors.
36. The applicant has proposed an acceptable screened refuse storage area along the north property line, adjacent to Main Street. Delivery, loading, and unloading zones for the private event facility will be limited to Heber Avenue.
37. The event space is intended to be privately owned and professionally managed. The applicant anticipates that the number of employees will vary from 4 to 40 based on the event; as previously noted, the applicant anticipates events no larger than an occupant load of 480.
38. The site is located within the Park City Soils Ordinance boundary and FEMA flood Zone A.
39. The site is located in a FEMA flood Zone A.
40. The CUP application was deemed complete on September 28, 2016 upon receipt of additional materials.

41. The proposed conditional use meets the criteria set forth in LMC 15-1-10(E).
42. The staff findings in the Analysis section of this report are incorporated herein.

### **Conclusions of Law**

1. The CUP, as conditioned, is consistent with the Park City Land Management Code.
2. The proposed use, as conditioned, will be compatible with the surrounding structures in use, scale, mass and circulation.
3. The effects of any differences in use or scale have been mitigated through careful planning.

### **Conditions of Approval**

1. All standard conditions of approval apply to this Conditional Use Permit for a Private Event Facility as well as a temporary tent.
2. Should the owner host an event in the Private Event Facility that goes beyond the Private Event Facility Use and the Conditions of Approval outlined in this CUP, a Special Event permit may be required.
3. Guests and patrons using the Private Event Facility shall abide by the same parking and access restrictions as other visitors to Main Street.
4. The applicant, at its cost, shall incorporate such measures to ensure that any safety, health, or sanitation equipment, and services or facilities reasonably necessary to ensure that the events will be conducted with due regard for safety are provided and paid for by the applicant.
5. The owner shall orient the activities so as to minimize sound impacts to the neighborhoods and the applicant shall monitor the following:
  - a. The owner, or his/her designee, shall provide on-site management for each aspect of the event.
  - b. The owner shall be responsible to ensure that the sound system maintains level adjustments not to exceed provisions of the Park City Noise Ordinance for the outdoor use.
6. All exterior signs require a separate sign permit reviewed by the Planning and Building Departments and multi-tenant buildings require a Master Sign Plan.
7. The final building plans and construction details for the project shall meet substantial compliance with the HDDR approved on June 20, 2016 and the drawings reviewed by the Planning Commission on November 9, 2016.
8. Utility and grading plans, including storm water drainage plans, must be approved by the City Engineer prior to Building Permit issuance.
9. A Utility Plan must be provided at the time of the building permit application showing the location of dry facilities on the property to ensure that the location of transformers and other utility infrastructure on the property can be adequately screened and written approval from the utility company is provided indicating that are satisfying this condition

10. All exterior mechanical equipment shall be painted and/or otherwise screened and shielded from public streets. All wall and roof top vents and protruding mechanical shall be painted to match the adjacent wall or roof and/or screened from public view.
11. The use of umbrellas, portable heaters, and similar improvements may be used during an event; however, they shall not be permanently stored on the rooftop terrace or visible from the public right-of-way except when in use during the private event.
12. Any proposed tent shall comply with the following regulations:
  - a. The tent shall not increase the occupancy of the existing building.
  - b. The tent shall be setback from the parapet along Heber Avenue and the south edge of the roof terrace in order to limit its visibility and mass from the street.
  - c. The tent shall be solid in color; however, it may have some clear openings such as windows or doors. The colors and materials of the tent shall complement the building and shall not contain reflective material.
  - d. The tent shall be no more than fifteen feet (15') in height.
  - e. The tent's installation and/or disassembly shall not require the use of any machinery such as cranes, compressors, or generators. Hand portable air compressors may be used to operate power tools as necessary.
  - f. The tent shall not be erected for more than four (4) consecutive days up to fifteen (15) times per year (including setup and removal), except for the once a year in which the tent shall be allowed to be erected for ten (10) days (including setup and removal). The number of days the tent is up shall not exceed 70 days, as required by LMC 15-4-16.
  - g. The applicant is responsible for coordinating the necessary building permits with the Building Department for all plans for tents.
  - h. The size of the tent shall be limited to 780 square feet.
  - i. The rooftop terrace shall be limited to one (1) tent.
  - j. The applicant shall provide an exhibit showing the location of the tent and dimensioned in feet and inches.
13. The hours of operation within the interior shall be limited to 8am to midnight.
14. The rooftop terrace shall not be used for activities that may create dust or odor, such as but not limited to cooking.
15. The owner shall not permit or provide either live or recorded amplified music within the interior of the space without first having closed all exterior doors and windows of the licensed premise. Doors may be opened to provide ingress and egress, but shall not be blocked in the open position to provide ventilation. Doors shall be equipped with automatic closing devices to keep them in the closed position except to permit ingress and egress of patrons.
16. Outdoor speakers will only be allowed between the hours of 11am to 10pm.
17. The applicant agrees to abide by all current and future Park City municipal

codes.

18. The applicant must submit a condo plat in order to sell any of the individual retail/commercial units.
19. A final Construction Mitigation Plan must be approved by the Planning and Building Departments prior to issuance of a building permit.
20. All projects within the Soils Ordinance Boundary require a Soil Mitigation Plan to be submitted and approved by the Building and Planning Departments prior to issuance of a Building Permit.
21. Property is located in a FEMA flood Zone A. The lowest occupied floor shall be at or above the base flood elevation. Additionally, an H and H study must be completed showing the impacts to the flood plain. Any changes to the flood plain by 12 inches or more will require the filing of a LOMR.
22. All exterior lighting, including any existing lighting and lighting on the balcony and terrace, shall comply with the Lighting Requirements of LMC 15-5-5(I). The lighting shall be downward directed and fully shielded. Exterior lighting shall be approved by the Planning Department prior to installation.
23. In the event that sustained code violations are registered with the City regarding this use, including complaints of glare, noise, smoke, odor, grease, or traffic, the applicant will be required to address the code violation within 30 days. The Planning Department shall investigate these complaints and take measures necessary to ensure that the property owner complies with the requirements of this permit. Additionally, the Planning Department may bring forward these complaints to the Planning Commission, as deemed necessary by the Planning Director, in order to further mitigate the nuisance. Should these code violations not be mitigated, the Planning Commission may revoke this CUP.

If you have questions regarding your project or the action taken please don't hesitate to contact me at 435-615-5067 or [anya.grahn@parkcity.org](mailto:anya.grahn@parkcity.org).

Sincerely,



Anya Grahn  
Historic Preservation Planner

# Acoustical Report

To: Nestor Gallo  
Park City

CC: Anya Grahn  
Park City

From: Joe Morris

Date: 11 September 2018

Re: Park City Kimball Building - Environmental Acoustic Review

---

## OVERVIEW

On 06 September 2018, a site visit was made to the Kimball building (638 Park Ave.) in Park City, UT to assess the existing environmental acoustical conditions and discuss further necessary actions. In attendance were multiple personnel including the architect, Craig Elliott, John Maxfield from Columbus Pacific Development, Jay Randall from the Park City Police Department, and other Park City officials.

The initial acoustical report from Henderson Engineers, "Henderson Report", was discussed as to the procedures and results of the measurements, and I took ambient acoustical measurements from the same location as the Henderson Report to view some of the major noise, which are shown in the report below. While I was taking these measurements on the roof of the southwest corner of the building, discussions were occurring on the main terrace between approximately five people (see *Appendix A, Figure 1*). Not all were talking at once and at different points there were multiple conversations occurring at the same time, but it was difficult to distinguish their conversation or that there were discussions even occurring. I had to focus my senses to hear the conversation because of the noise displayed from construction, automobile traffic including busses, and the general ambiance masking those conversations.

Please find the following brief analysis of the measurements taken and the Henderson Report. Measurements were taken using a Type 2 microphone and analyzed with the AudioTools Software. The figures and graph can be found in *Appendix A*.

## ANALYSIS

Measurements were taken at the Kimball Building rooftop on the southwest corner (as shown in *Figure 2* and *Figure 3*), similar to where measurements were taken in the Henderson Report. *Graph 1* represents the measurements taken at this location during the September 6<sup>th</sup> site visit. The conversation locations are shown in *Figure 1* and *Figure 2*: (1) on the south side of the terrace in direct line-of-sight of the measurement location and (2) on the northern side of the terrace with the dome between the people and measurement location 1.

The maximum Sound Pressure Level (Lp) obtained was ~61 dBA (A-weighted decibel level). A loud motorcycle and a bus passed through during these measurements, providing these peaks in sound. The motorcycle is a temporary sound contributor, but the busses run

regularly. The sound levels from the traffic and construction noise masked the sound coming from the people on the terrace.

A sound masking system works to help isolate the sound from a single or multiple sources from one or multiple receivers. For example, a sound masking loudspeaker playing white noise may be used outside the door of an office or conference room to add more isolation and privacy. This is what I believe is happening between the Kimball building (source) and the residential area (receiver).

Also shown in *Graph 1*, the lowest  $L_p$  in the mid-frequencies (speech) ranged from 38-42 dBA (+/- 2 dBA), which shows that in order for the  $L_p$  to elevate past the 50-60 dBA would require an increase of at least 10 dBA greater than what is presently produced in the overall ambiance. The Henderson Report proves that this is not likely for speech and music due to the distances the sound would have to travel, and the level to which the sound would have to increase to overpower the existing noise conditions, particularly the regular occurrences of busses.

## CONCLUSION

Based upon the site-investigation and the analysis of the Henderson Report, it is my opinion that the sounds from the events held within the Kimball Building and on the Terrace would not exceed the noise limits determined by the Park City Municipal Code Section 6-3-9. The levels generated by the people per conversations or through music would dissipate over the distance from the terrace to the residential property line, scatter because of the construct of the dome, and become masked over the existing traffic and other environmental noise.

The only occurrence when the noise level could exceed the city standards is during the hours between 10:00 pm – 6:00 am on cold nights with snow on the ground. The cold air and snow typically carry sound more quickly over longer distances than during warm nights, because the air molecules are closer together in cold air and can vibrate more rapidly one to another. I would recommend limiting how frequently the doors of the Kimball building are opened during events on the second floor on frigid nights, not necessarily for, nor limited to, speech noise but for music as well. If heavy low end music (music with lots of lower frequencies or bass like drums or subwoofers) is played in these areas, then further treatment could be required.

Please feel free to contact me with any questions or concerns regarding this report.



Joe Morris  
BS-Applied Physics, M-ASA, CTS

## Appendix A



Figure 1: Collaboration of Kimball Building team from measurement location 1 (refer to Figure 2 for measurements locations)

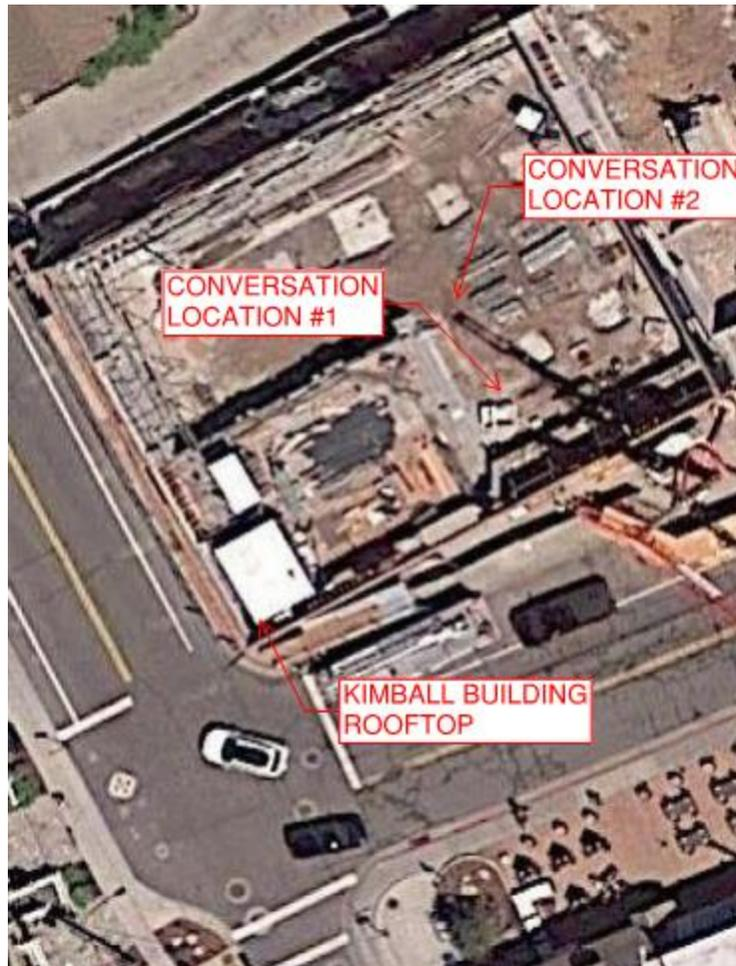
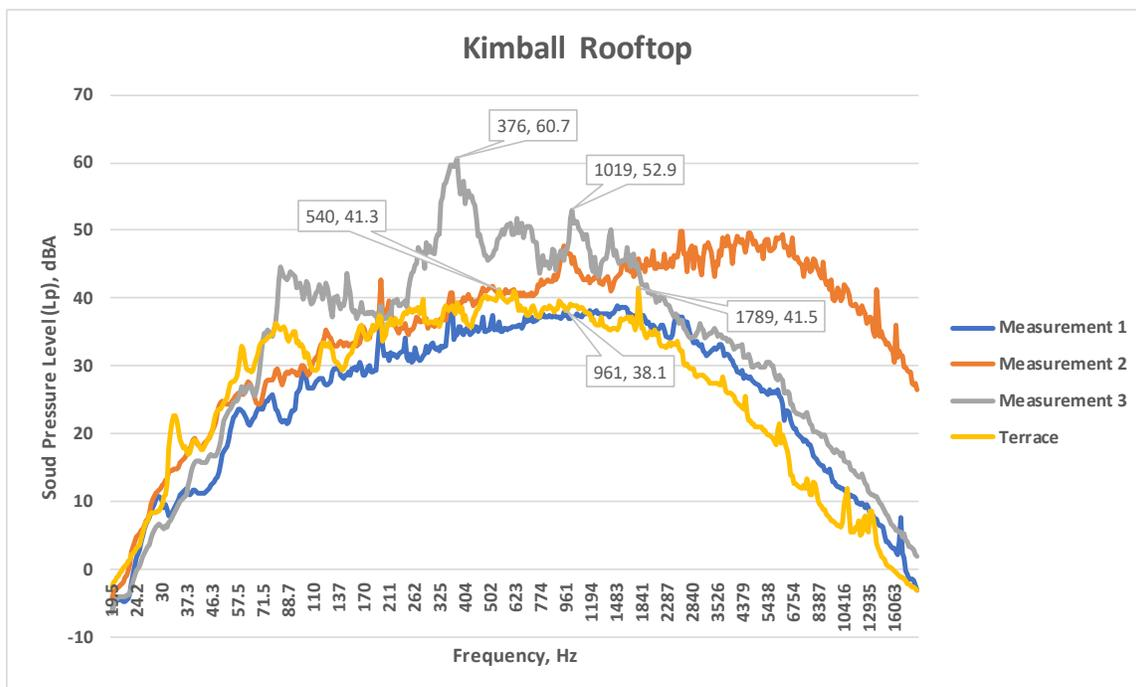

Figure 2: Measurement and Conversation Locations



Figure 3: Measurement Location on Kimball Building Rooftop



Graph 1: Measurements 1-4 of the rooftop location on the southwest corner of the Kimball Building including the Terrace.

## Memo

**Subject:** Kimball Private Event Space- Rooftop Terrace  
**Address:** 638 Park Avenue  
**Project#:** PL-16-03412  
**Date:** September 19, 2018

On Tuesday, September 18, 2018, Chief Building Official Dave Thacker, Deputy Chief Building Official Michelle Downward, Sargent Jay Randall, and Historic Preservation Planner Anya Grain met with John Maxfield of Columbus Pacific Development to conduct an acoustical analysis. The purpose was to conduct an analysis with conditions reflective of an average event activity (music playing and evening temperatures). With these findings, and consideration of previous public input and studies, staff established the following recommendation regarding the special event use conditional use permit application. Staff's priority is to ensure that enforcement staff is prepared and equipped with the best management practices and enforcement tools necessary to affectively enforce any violations which may occur.

The group met on-site at the rooftop terrace of the Kimball at 638 Park Avenue at 9pm. The acoustical analysis was conducted from 9pm to 10:30pm. The temperature during this time was reported to be 71.1°F at 8:56pm, 68.0°F at 9:56pm, and 60.1°F at 10:56pm. The wind speed varied between 9.2 to 6.9 miles per hour. Conditions were clear.

At the time of the analysis, the Kimball building was still under construction. No glass railings or landscaping had yet been installed surrounding the rooftop terrace.

Prior to playing the music as part of the acoustical analysis, staff noted that Old Town was especially quiet, with the exception of occasional traffic turning from Park Avenue onto Heber Avenue. The loudest audible sound was from exhaust vents south of the Kimball site. Ambient noise of 52 dBA was measured on the terrace.

A baseline ambient reading of 47 dBA was taken at 631 Park Avenue and 44 dBA on both 621 Park Avenue and the intersection of Heber Ave & Park Avenue. These measurements were taken without outside interference such as automobile or pedestrian traffic, and were static over a few minutes. These measurements were taken on the porches of each residence, at or above the same elevation as the Kimball rooftop terrace.

Sound level meters Class 1 Type 1 meter, which satisfy ANSI S1.4-1983, were utilized to measure the sound pressure levels of the music from the speakers on the terrace (with the speakers on terrace floor level) and then staff took sound pressure measurements in several surrounding locations. The following table shows staff's measurements at various sound pressure levels on the terrace.

		Session 1	Session 2	Session 3
Source Sound Level Created On The Kimball Terrace From Test Source		80 dBA	85 dBA	90-93 dBA
<b>RECEPTOR LOCATION AND SOUND LEVEL READING</b>	631 Park Avenue	53	61	66
	Park Ave. & Heber Ave.	51	60	66
	631 Park Avenue	53	59	65
	Main Street & Heber Avenue (southwest corner)	52	55	63
	Park & Heber Avenue (at Stop Sign)	49	54	57
	High West at 703 Park Avenue	52		51
	Crescent Tramway & Woodside Avenue	43-45	50	48
	Crescent Tramway & Town Lift (near Norfolk Avenue)	48		52
	Town Lift Bridge (Standing in the Middle)	49		54
	Bahnhof Sport at 693 Main Street (Standing on 7 <sup>th</sup> Street, facing Parking Garage entrance)	Not audible	Not audible	58

Using two large (about 3 foot tall) portable speakers connected to a phone, Staff conducted the initial measurements with music measuring at a sound pressure level of 80 dBA. This was measured next to the speaker, no more than 5 feet away. In order to have a sound pressure analysis comparable to what an event may be permitted to host in the future, staff increased the sound pressure level to 85 and 90 dBA on the terrace.

On the corner of Woodside and Park Avenues, we found that the chatter emitting from guests inside High West was louder than the music on the Kimball's rooftop patio. We then asked the occupants on the terrace to speak loudly to simulate occupants on the terrace of the Kimball, and we took measurements from 639 Park Avenue; we measured the dBA to be 63 with loud talking above the music.

At 85 dBA, we determined that the results were not significantly different than at 80 dBA. Staff anticipates that the typical sound level on the deck during an event will be much less than 80 dBA as the applicant has committed that their sound measuring device will turn off any speakers that exceed 65 dBA; however, staff found that the any sound exceeding 85 dBA would likely violate the City's Noise Ordinance.

With music playing at 90 to 93 dBA and we found that the sound was clearly audible and potentially disruptive to neighboring properties. Song lyrics were audible from several streets over, including Woodside Avenue, Norfolk Avenue, and Seventh Street. Staff in these surrounding areas had to raise their voice above the sound pressure level of the music in order to hold a conversation. It was equally difficult to converse standing

on the street below on the west side of Park Avenue. On the terrace, it was impossible to hold a conversation.

While many factors can affect how sound travels over distance, including temperature, wind, weather conditions, speaker orientation and the installation of the railing and landscaping, staff has come to the following conclusions:

- The site conditions result in sound traveling to other properties comparable in elevation and above.
- The amount of sound dissipation over distance creates a situation within which activities could be hosted and maintained on the terrace in compliance with the noise ordinance.
- The installation of a guardrail and landscaping will likely mitigate the amount of sound that escaped the boundary of the terrace.
- Sound pressure levels on the terrace of 90 dBA, consistent with other event approvals, would likely result in violations of the noise ordinance and be disturbing to neighboring properties.

Staff concludes that the responsible management of the terrace space will determine the compatibility of the special event use. As a result, it is recommended that the Planning Commission provide enforcement staff with the best management practices and tools necessary to affectively enforce any violations which may occur. These tools and safeguards are reflected within the staff report as conditions of approval.

## Summary of Past CUPs of Similar Uses

Date of CUP Approval by Planning Commission	Type of Use	Time Limit on Operations	Noise Study Requirements	Event Management Plan	Parking Mitigation	Review Period
1.13.1999	Private Club		<p>C#3. A study shall be conducted by the applicant for noise proofing and vibration proofing. All windows, roofs, ducts, vents, and other areas that allow noise at levels exceeding those allowed by the Park City Municipal Code to projects outside of the building, in particular towards Park Avenue, shall be soundproofed to a reasonable degree, with the inspection and final approval by the Building Department. This sound proofing and vibration proofing shall occur prior to issuance of a final certificate of occupancy.</p>	<p>C#8. An Event Management Plan shall be prepared and reviewed by the Planning Department. The Event Management Plan shall include provisions for ticket sales and arriving and department guests for those times when the establishment is operating over and above normal night club use and occupancy levels....</p>	<p>C#8. ...A Parking Management Plan shall be prepared to identify parking activities and alternatives to parking for above normal operation levels of the club and potential extraordinary operation levels of the club.</p>	<p>C#7. A Conditional Use Permit shall be reviewed by the Community Development Department at six months and one year from the date of the CUP approval. If complaints are received or violations of the Conditional Use Permit or any City Code occur (including Sign Code, Lighting Ordinance, and Building Department recommendations on sound proofing), the Community Development Department shall schedule the Conditional Use Permit for the Planning Commission at the time of the complaint to determine whether the Conditional Use Permit should be revoked or additional conditions of approval should be added.</p>
9.1.2004	Outdoor Events	F. #13. This entertainment will cease prior to 10:00pm.		<p>C#4. It is expected that PMCC shall continue to hold private, Outdoor Events. PMCC shall provide advance written notification to the Park City Planning Department of each event they plan to hold. Individual specifics and details for each event shall be required to ensure consistency with this approval. In the case PMCC wishes to erect a tent or other equipment, a building permit and review for consistency with this Conditional Use Permit as well as current Municipal, and Building Codes shall be required.</p>	<p>C#5. The erection of any tents or other equipment shall not displace available, private parking to the level of impacting emergency access or causing circulation or parking issues on any of the adjacent public streets.</p>	<p>C#3. A one-year review of this permit shall be conducted prior to the summer '06 outdoor event season. If at that time staff finds that PMCC has conducted their summer events in compliance with this approval and all other requisite City Codes, this approval shall be extended indefinitely.</p>
8.11.2006	Outdoor Events	<p>F. #6. These private may have outside (live) entertainment. This entertainment will cease prior to 10:00pm.</p> <p>C. #2. Should the Brother III request Relief from the noise ordinance through Section 6-3-11 of the Municipal Code, written approval, specific to the event, from the Building Official, Police Department, and Special Events Department is required. Additional specific conditions of approval may be considered as part of this relief and any conditions agreed upon shall be compiled by the applicant and failure to do so will cause the relief agreement to be suspended.</p>	<p>C. #5. Brothers III, LLC shall provide advance written notification (e-mail is acceptable) to the Park City Planning Department of each event they plan to hold. Individual specifics and details for each event shall be required to ensure consistency with this approval. In the case Brother's III, LLC wishes to erect a tent or any other equipment, a building permit and review for consistency with the Conditional Use Permit as well as current Municipal, and Building Codes shall be required. The Planning Staff will provide this information to the Police Department dispatch to alert them of the event.</p>	<p>C. #4. A one-year review of this permit shall be conducted prior to the summer '07 outdoor event season. If at that time staff finds that Brother's III, LLC has conducted their summer events in compliance with this approval and all other requisite City Codes, this approval shall be extended indefinitely.</p>		

**The Yard** 12.22.10 Indoor Entertainment Facility and Commercial Parking Lot

C.#3. All uses must comply with the Park City Noise Ordinance.

C.#4. The detailed submittal must be submitted to the Park City Planning Department at least two (2) weeks (ten business days) before any event for review and approval by the Chief Building Official and the Planning Department. The detailed submittal includes without limitation, a traffic mitigation plan that includes consideration of safety concerns for access to parking off of Homestead Road.

C.#8. If the City receives more than three complaints from residents, the CUP would come back to the Planning Commission for modifications to the CUP.



October 5, 1999

Doug Illman  
Harry O's  
P O Box 3118  
Park City UT 84060

Department of Community Development  
Engineering • Building Inspection • Planning

NOTICE OF PLANNING COMMISSION ACTION

Project Name Harry O's  
Project Description CUP for private club  
Date of Meeting January 13, 1999

Action Taken By Planning Commission Approved in accordance with the findings of fact and conclusions of law as outlined in the staff report except that finding #6 as written shall be replaced with the following wording: "Given the size and scope of the request and the potential for noise and vibration impacts on adjacent properties, a sound study is needed". The conditions of approval for the project are listed below.

Conditions of Approval

1. All standard project conditions of approval shall apply.
2. Rear and side exit doors providing access to Park Avenue shall not be used as an entrance or exit to the club by club patrons except in times of emergency.
3. A study shall be conducted by the applicant for noise proofing and vibration proofing. All windows, roofs, ducts, vents, and other areas that allow noise at levels exceeding those allowed by the Park City Municipal Code to projects outside of the building, in particular towards Park Avneue, shall be soundproofed to a reasonable degree, with the inspection and final approval by the Building Department. This sound proofing and vibration proofing shall occur prior to issuance of a final certificate of occupancy.
4. As a condition p[recedent to issuance of a final certificatr of occupancy, all exterior lighting shall be brought into compliance with applicable City ordinances asnd codes. Any and all new lighting shall comply with City ordinances and codes.
5. A Master Sign Plan meeting requirements for Master Sign Plans as stated in the Sign Code for the existing building shall be submitted by the applicant for approval by the Historic District Commission and Community Development Department within three months of the Conditional Use Permit approval.
6. Pursuant to the Z-Place Parking License and Stairway Maintenance Agreement Book No. 550, Page 263, recorded January 8, 19909, with the Summit Countyt Recorder's Office, the property owner shall assume all responsibility, liability, and maintenance of the public walkway on the south side of the building.
7. A Conditional Use Permit shall be reviewed by the Community Development Department at six months and one year from the date of CUP approval. If complaints are received or violations of

Park City Municipal Corporation • 445 Marsac Avenue • P.O. Box 1480 • Park City, UT 84060-1480  
Community Development (435) 615-5055 • Engineering (435) 615-5055 • Building (435) 615-5100  
Planning (435) 615-5060 • FAX (435) 615-4906



September 1, 2004

Park Meadows Country Club  
Leah Jackson  
PO Box 680430  
Park City, UT 84068

**RE: Outdoor Event Administrative CUP Approval: Park Meadows Country Club**

Dear Applicant,

The Planning Department has reviewed and approved your application to modify your existing Conditional Use Permit approval based on the information found below. Per your written request on August 19, 2004 (attached) regarding the sound system at your outdoor pool. As with your existing CUP, this approval runs with the land and will not expire at the end of the summer season. This letter acts as the official notice of approval.

According to the Park City Municipal Land Management Code: Outdoor Events and Music may be permitted in the Recreation Open Space (ROS) District subject to all requirements of this code, including Section 15-1-10, Conditional Use Review, and the following criteria:

- a. Notification of adjacent property owners (300');
- b. No violation of the City Noise Ordinance, Title 6 (see portions of the Park City Municipal Code as they relate to noise attached);
- c. Impacts on adjacent residential uses;
- d. Proposed plans for music, lighting, structures, electrical signs, etc.;
- e. Parking demand and impacts on neighboring properties;
- f. Duration and hours of operation;
- g. Impacts on emergency access and circulation.

**FINDINGS OF FACT:**

Upon review of your application, staff finds that:

- 1. This application has been reviewed under Section 15-1-10 of the Land Management Code and criteria a-g as found above.
- 2. The application, as conditioned, complies with all requirements of the Land Management Code, Section 15-1-10.
- 3. Coalition Title Company conducted a title search on May 26, 2004 and determined there are no residents within 300' of the Park Meadows Club House.
- 4. The dates of the requested event(s) at Park Meadows Country Club (PMCC) that require the use of an additional tent will be August 4 – 14, 2004.
- 5. These events include the PMCC's annual golf tournament (The Kemosabi) from August 4-7, as well as a wedding on August 14, 2004.
- 6. To facilitate the events a tent will be located on private property in an existing overflow parking lot (see attached exhibit A). The dimensions of the tent will be 60' x 100', and

- be used to expand the floor space of the Clubhouse.
7. The use of the space will be used as a reserve in case of inclement weather, in which case only the wedding ceremony and cocktail party will occur in this location.
  8. All of the events are private.
  9. During the Kemosabi, live entertainment will be provided from inside the clubhouse. It will cease at 10:00 pm.
  10. The applicant has also requested permission to have additional private events serving their private members on the following dates:
    - a. May 30, 2004 (Memorial Day)
    - b. July 4, 2004 (4<sup>th</sup> of July)
    - c. August 13 (End of Summer BBQ)
    - d. September 5 (Labor Day)
  11. PMCC has not requested the use of tents for these events.
  12. These private member events, a-d, as listed in FOF # 10, will have outside (live) entertainment, located underneath the awning found at the rear (west elevation) of the clubhouse.
  13. This entertainment will cease prior to 10:00 pm.
  14. No additional signs or lighting have been proposed with this application.
  15. PMCC has an outdoor pool. An outdoor sound system exists at the pool. The hours of operation for the pool are 8:00 am – 7:00 pm.

**CONDITIONS OF APPROVAL:**

1. Nothing herein shall allow any violation to the International Fire Code, International Building Code, or Park City Municipal Code, including any violation of the Municipal Noise Ordinance. Please find specifics as they pertain to this approval attached (Sections 6-3-8 and 6-3-9 attached).
2. If a tent is being erected, a tent permit shall be secured from the City's Building Department. All equipment for lighting, heating, power, etc., specifications for wind and snow loads, as well as exiting, and occupancy requirements must be reviewed and approved prior to installation of the tent.
3. A one-year review of this permit shall be conducted prior to the summer '06 outdoor event season. If at that time staff finds PMCC has conducted their summer events in compliance with this approval and all other requisite City Codes, this approval shall be extended indefinitely.
4. It is expected that PMCC shall continue to hold private, Outdoor Events. PMCC shall provide advanced written notification to the Park City Planning Department of each event they plan to hold. Individual specifics and details for each event shall be required to ensure consistency with this approval. In the case PMCC's wishes to erect a tent or any other equipment, a building permit and review for consistency with this Conditional Use Permit as well as current Municipal, and Building Codes shall be required.
5. The erection of any tents or other equipment shall not displace available, private parking to the level of impacting emergency access or causing circulation or parking issues on any of the adjacent, public streets.

Thank you for your cooperation in this matter. Please feel free to call me at 615-5069, if you have any questions.

Sincerely,

Jonathan Weidenhamer  
Planner



**Department of Community Development**  
Engineering • Building Inspection • Planning

June 23, 2004

Park Meadows Country Club  
Leah Jackson - Food and Beverage Manager  
2000 Meadows Drive  
PO Box 680430  
Park City, UT 84068

**RE: Outdoor Event Administrative CUP Approval: Park Meadows Country Club**

Dear Applicant,

The Planning Department has reviewed and approved your application based on the information found below. This letter acts as the official notice of approval.

According to the Park City Municipal Land Management Code: Outdoor Events may be permitted in the Recreation Open Space (ROS) District subject to all requirements of this code, including Section 15-1-10, Conditional Use Review, and the following criteria:

- a. Notification of adjacent property owners (300');
- b. No violation of the City Noise Ordinance, Title 6 (see portions of the Park City Municipal Code as they relate to noise attached);
- c. Impacts on adjacent residential uses;
- d. Proposed plans for music, lighting, structures, electrical signs, etc.;
- e. Parking demand and impacts on neighboring properties;
- f. Duration and hours of operation;
- g. Impacts on emergency access and circulation.

**FINDINGS OF FACT:**

Upon review of your application, staff finds that:

1. This application has been reviewed under Section 15-1-10 of the Land Management Code and criteria a-g as found above.
2. The application, as conditioned, complies with all requirements of the Land Management Code, Section 15-1-10.
3. Coalition Title Company conducted a title search on May 26, 2004 and determined there are no residents within 300' of the Park Meadows Club House.
4. The dates of the requested event(s) at Park Meadows Country Club (PMCC) that require the use of an additional tent will be August 4 – 14, 2004.

Park City Municipal Corporation • 445 Marsac Avenue • P.O. Box 1480 • Park City, Utah 84060-1480  
Community Development (435) 615-5055 • Engineering (435) 615-5055 • Building (435) 615-5100  
Planning (435) 615-5060 • FAX (435) 615-4906

5. These events include the PMCC's annual golf tournament (The Kemosabi) from August 4-7, as well as a wedding on August 14, 2004.
6. To facilitate the events a tent will be located on private property in an existing overflow parking lot (see attached exhibit A). The dimensions of the tent will be 60' x 100', and be used to expand the floor space of the Clubhouse.
7. The use of the space will be used as a reserve in case of inclement weather, in which case only the wedding ceremony and cocktail party will occur in this location.
8. All of the events are private.
9. During the Kemosabi, live entertainment will be provided from inside the clubhouse. It will cease at 10:00 pm.
10. The applicant has also requested permission to have additional private events serving their private members on the following dates:
  - a. May 30, 2004 (Memorial Day)
  - b. July 4, 2004 (4<sup>th</sup> of July)
  - c. August 13 (End of Summer BBQ)
  - d. September 5 (Labor Day)
11. PMCC has not requested the use of tents for these events.
12. These private member events, a-d, as listed in FOF # 10, will have outside (live) entertainment, located underneath the awning found at the rear (west elevation) of the clubhouse.
13. This entertainment will cease prior to 10:00 pm.
14. No additional signs or lighting have been proposed with this application.

**CONDITIONS OF APPROVAL:**

1. Nothing herein shall allow any violation to the International Fire Code, International Building Code, or Park City Municipal Code, including any violation of the Municipal Noise Ordinance. Please find specifics as they pertain to this approval attached (Sections 6-3-8 and 6-3-9 attached).
2. If a tent is being erected, a tent permit shall be secured from the City's Building Department. All equipment for lighting, heating, power, etc., specifications for wind and snow loads, as well as exiting, and occupancy requirements must be reviewed and approved prior to installation of the tent.
3. A one-year review of this permit shall be conducted prior to the summer '06~~5~~ outdoor event season. If at that time staff finds PMCC has conducted their summer events in compliance with this approval and all other requisite City Codes, this approval shall be extended indefinitely.
4. It is expected that PMCC shall continue to hold private, Outdoor Events. PMCC shall provide advanced written notification to the Park City Planning Department of each event they plan to hold. Individual specifics and details for each event shall be required to ensure consistency with this approval. In the case PMCC's wishes to erect a tent or any other equipment, a building permit and review for consistency with this Conditional Use Permit as well as current Municipal, and Building Codes shall be required.
5. The erection of any tents or other equipment shall not displace available, private

parking to the level of impacting emergency access or causing circulation or parking issues on any of the adjacent, public streets.

Thank you for your cooperation in this matter. Please feel free to call me at 615-5069, if you have any questions.

Sincerely,

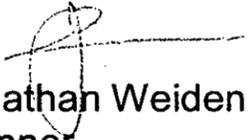

Jonathan Weidenhamer  
Planner



August 11, 2006 **Building Department • City Engineer • Planning and Zoning**

Brothers III, LLC  
PO Box 2429  
Park City, UT 84060

**RE: Outdoor Event Administrative CUP Approval: 825 Main St- Town Lift Plaza**

Dear Applicant,

The Planning Department has reviewed and approved your application to approve your administrative Conditional Use Permit based on the information found below. The types of uses and activities, as outlined in your written request of July 28, 2006 (attached) are permitted, with the exception of any events associated with a Master Festival License or a Special Event Permit. Those uses shall continue to be reviewed under the Master Festival and Special Event Permitting processes. This approval runs with the land and will not expire at the end of the summer season. This letter acts as the official notice of approval.

According to the Park City Municipal Land Management Code: Outdoor Events and Music may be permitted in the Historic Business Commercial (HCB) and Historic Recreation Commercial (HRC) Districts subject to all requirements of this code, including Section 15-1-10, Conditional Use Review, and the following criteria:

- a. Notification of adjacent property owners (300');
- b. No violation of the City Noise Ordinance, Title 6 (see portions of the Park City Municipal Code as they relate to noise attached);
- c. Impacts on adjacent residential uses;
- d. Proposed plans for music, lighting, structures, electrical signs, etc.;
- e. Parking demand and impacts on neighboring properties;
- f. Duration and hours of operation;
- g. Impacts on emergency access and circulation.

**FINDINGS OF FACT:**

Upon review of your application, staff finds that:

1. This application has been reviewed under Section 15-1-10 of the Land Management Code and criteria a-g as found above.
2. The application, as conditioned, complies with all requirements of the Land Management Code, Section 15-1-10.
3. On August, 2006, the City sent notice letters to all property owners within 300' based on a list provided by your title company.

Park City Municipal Corporation • 445 Marsac Avenue • P.O. Box 1480 • Park City, UT 84060-1480  
Building Department • (435) 615-5100 • FAX (435) 615-4900  
City Engineer • (435) 615-5055 • FAX (435) 615-4906  
Planning and Zoning • (435) 615-5060 • FAX (435) 615-4906

4. Some events may require the use of temporary tents.
5. The events are primarily private events, including parties, weddings, and receptions, however some public events are proposed, such as Santa Claus on the deck, music, art shows, moving screenings, etc. Larger private and public events associated with a Master Festival or a Special Event will continue to be reviewed by the Master Festival and Special Events process.
6. These private may have outside (live) entertainment. This entertainment will cease prior to 10:00 pm.
7. No additional signs or lighting have been proposed with this application.
8. Section 6-3-11 (Relief from Restrictions) of the Park City Municipal Code allows the Police Department to consider temporary relief from the Noise Ordinance. Requests for relief from the noise restrictions may be made by the Building Official as it pertains to building issues and by the Chief of Police as it pertains to special events and community or private functions or events. Upon granting relief, any conditions outlined and agreed upon shall be complied by the applicant and failure to do so will cause the relief agreement to be suspended. This is addressed as condition of approval number 2.

**CONDITIONS OF APPROVAL:**

1. Nothing herein shall allow any violation to the International Fire Code, International Building Code, or Park City Municipal Code, including any violation of Section 6-3-9(B) of the Municipal Noise Ordinance. Please find specifics as they pertain to this approval attached.
2. Should the Brothers III request Relief from the noise ordinance through Section 6-3-11 of the Municipal Code, written approval, specific to the event, from the Building Official, Police Department, and Special Events Department is required. Additional specific conditions of approval may be considered as part of this relief and any conditions agreed upon shall be complied by the applicant and failure to do so will cause the relief agreement to be suspended
3. If a tent is being erected, a tent permit shall be secured from the City's Building Department. All equipment for lighting, heating, power, etc., specifications for wind and snow loads, as well as exiting, and occupancy requirements must be reviewed and approved prior to installation of the tent.
4. A one-year review of this permit shall be conducted prior to the summer '07 outdoor event season. If at that time staff finds that Brother's III, LLC has conducted their summer events in compliance with this approval and all other requisite City Codes, this approval shall be extended indefinitely.
5. Brothers III, LLC shall provide advanced written notification (e-mail is acceptable) to the Park City Planning Department of each event they plan to hold. Individual specifics and details for each event shall be required to ensure consistency with this approval. In the case Brother's III, LLC wishes to erect a tent or any other equipment, a building permit and review for consistency with this Conditional Use Permit as well as current Municipal, and Building Codes shall be required. The Planning Staff will provide this information to the Police Department dispatch to alert them of the event.

6. Special Events and events associated with a Master Festival License shall be reviewed by the City according to the Master Festival License and Special Events permitting process.
7. The erection of any tents or other equipment shall not displace available, private parking to the level of impacting emergency access or causing circulation or parking issues on any of the adjacent, public streets.
8. The Police Department hereby approves relief from the Noise Ordinance consistent with the findings above so that noise will be governed by Section 6-3-9(B) for 2006. This relief must be requested annually. Additional relief may be requested pursuant to condition #2 above.

Thank you for your cooperation in this matter. Please feel free to call me at 615-5066, if you have any questions.

Sincerely,

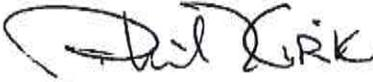
A handwritten signature in black ink that reads "Phil Kirk". The signature is stylized with a large, sweeping initial "P" and "K".

Lt. Phil Kirk  
Park City Police Department

The following are excerpts from the Park City Municipal Code:

**6-3-9. NOISE LEVELS.**

(B) The noise shall be measured at a distance of at least twenty-five feet (25') from the source of the device upon public property or within the public right-of-way or twenty-five feet (25') from the property line if upon private property, and shall be measured on a decibel or sound level meter of standard design and quality operated on the "A" weighing scale. A measurement of sixty-five (65) decibels shall be considered to be excessive and unusually loud.

**6-3-11. RELIEF FROM RESTRICTIONS.**

Requests for relief from the noise restrictions in these rules and regulations may be made by the Building Official as it pertains to building issues and by the Chief of Police as it pertains to special events and community or private functions or events. Upon granting relief, any conditions outlined and agreed upon shall be complied by the applicant and failure to do so will cause the relief agreement to be suspended.



**FILE COPY**

**Building • Engineering • Planning**

December 22, 2010

Michael E. Sweeney  
PO Box 2045  
Park City, UT 84060

**NOTICE OF PLANNING COMMISSION ACTION**

<b><u>Application #</u></b>	<b>PL-08-00481</b>
<b><u>Subject</u></b>	<b>The Yard CUP Extension</b>
<b><u>Address</u></b>	<b>1251 Kearns Boulevard</b>
<b><u>Description</u></b>	<b>Conditional Use Permit extension for Indoor Entertainment Facility and Commercial Parking Lot</b>
<b><u>Action Taken</u></b>	<b>Approved</b>
<b><u>Date of Action</u></b>	<b>October 13, 2010</b>

On October 13, 2010 the Park City Planning Commission called a meeting to order, a quorum was established, a public meeting was held. The Planning Commission approved the Conditional Use Permit Extension for an indoor entertainment facility and a commercial parking lot. located at 1251 Kearns Boulevard, based on the following Findings of Fact, Conclusions of Law, and Conditions of Approval:

**Finding of Fact:**

1. The property is located at 1251 Kearns Boulevard.
2. The zoning is General Commercial (GC) within the Frontage Protection Overlay Zone (FPZ).
3. The site is approximately 4.57 acres.
4. The site is bounded by Kearns Blvd. (Highway 248), Homestead Road, and Woodbine Way.
5. The site has existing sewer, electrical, and water capacity.
6. The parking area has enough room to handle 329 parking spaces.
7. An Indoor Entertainment Facility with the square footage of 14,110 will require seventy-two (72) parking spaces (5 parking spaces per 1,000 sq. ft.).
8. The medical office uses seven (7) parking spaces mandated by the LMC towards the front of the building.
9. The existing buildings on site will not be changed with this application.
10. The site does not contain any usable open space.

Park City Municipal Corporation • 445 Marsac Avenue • P.O. Box 1480 • Park City, Utah 84060-1480  
Building (435) 615-5100 • Engineering (435) 615-5055 • Planning (435) 615-5060  
FAX (435) 615-4906

11. The property owner has worked in the past with the Building Department regarding compliance with the Soils Ordinance. Currently the paved areas are in compliance with such ordinance.
12. The site has a legal non-conforming sign within the Frontage Protection Zone which has recently been updated.
13. The site has not changed since it was a lumber yard. The existing buildings on site will not be changed with this application.
14. The applicant does not expect any issues that might affect people other than what is currently found in a commercial area. The site will need to comply with the Park City Noise Ordinance.
15. The site plans (Exhibit A) shows the drop-off, loading, and (screened) dumpster areas located east of the building. The access to these areas is through the front, off Kearns Blvd.
16. The loading/unloading of the event equipment will take place prior to the actual events making the area free and clear when pedestrians are utilizing the same area for circulation.
17. The ownership is a limited liability company and has no unusual affects on taxing entities.
18. It is on relatively flat land and requires no slope retention and the buildings are pre-existing (no new buildings or remodeling on the outside on the buildings.)
19. The applicant requests to use temporary restroom facilities similar to that which is used for special events to meet this requirement depending on the events going on at the Yard.
20. Conditions of approval have been met by the applicant.

Conclusions of Law:

1. The application complies with all requirements of the LMC;
2. The uses will be compatible with surrounding structures in use, scale, mass and circulation;
3. The uses are consistent with the Park City General Plan, as amended; and
4. The effects of any differences in uses or scale have been mitigated through careful planning.

Conditions of Approval:

1. The internal layout of the parking plan shall be compliant with the applicable codes. The driving lanes shall be twenty-four (24') minimum.
2. The parking lot may be accessed via the entrance on Homestake Road, while the pedestrian circulation system may be located at the entrance to the site directly off Kearns Blvd. As noted on the site plan (Exhibit A).
3. All uses must comply with the Park City Noise Ordinance.
4. The detailed submittal must be submitted to the Park City Planning Department at least two (2) weeks (ten business days) before any event for review and

- approval by the Chief Building Official and the Planning Department. The detailed submittal includes without limitation, a traffic mitigation plan that includes consideration of safety concerns for access to parking off of Homestake Road.
5. All exterior lights must conform to park City lighting regulations for height, type, wattage and shielding.
  6. Permanent use of the property must conform to requirements for landscaping, snow storage, lighting and screening.
  7. This CUP does not include any events programmed for the site that goes through the City Special Events licensing or Master Festival Special Event permitting or master festival license process, i.e. outdoor events, etc.
  8. If the City receives more than three complaints from residents, the CUP would come back to the Planning Commission for modifications to the CUP.

If you have questions regarding your project or the action taken please don't hesitate to contact me at 435-615-5064 or [fastorga@parkcity.org](mailto:fastorga@parkcity.org).

Respectfully,



Francisco Astorga  
City Planner

cc: File  
Mark Fischer

# Event Center

## Traffic Study

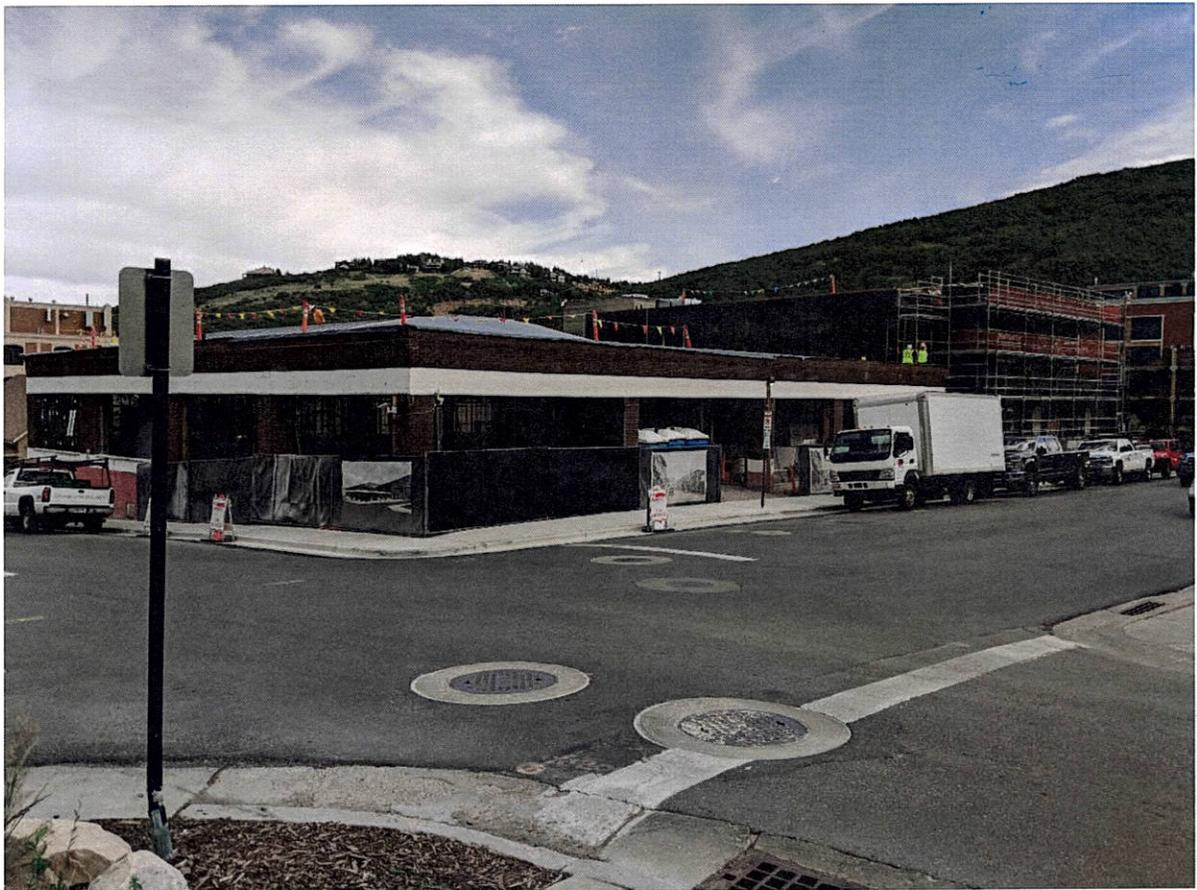

**Park City, Utah**

**September 5, 2018**

**UT18-1279**



## **EXECUTIVE SUMMARY**

This traffic study addresses the proposed Event Center in Park City, Utah. The Event Center will be located on the north side of Heber Avenue between Main Street and Park Avenue.

The purpose of the traffic study is to analyze existing traffic and parking patterns in the area, review the proposed occupancy of the proposed Event Center, and discuss how people will travel to and from the Event Center.

### **SUMMARY OF KEY FINDINGS/RECOMMENDATIONS**

The following is a summary of key findings and recommendations:

- It is anticipated that the maximum occupancy of the Event Center will be 480 people. According to city staff, a permit will be required for events with more than 250 guests.
- Based on historical traffic volumes, the highest volumes are experienced in January and July. The lowest volumes are experienced in April and May.
- Based on parking data collection between February and August 2018, the China Bridge structure alone may be able to support an event with 480 people approximately 72 percent of the time.
- Hales Engineering reviewed the existing parking on the block surrounding the Event Center to determine compliancy with City code. It is recommended that the curb be painted red at the corners of the intersections at least 15 feet from the intersections, at least 20 feet from the crosswalk, and 30 feet from stop signs. It is recommended that the west side of Main Street be red-curbed between Heber Avenue and 7th Street.
- Park City has parking throughout the downtown area in the form of both off-street and on-street parking. Because the proposed Event Center project does not include on-site parking, guests will park in one of the many parking locations in Park City Downtown. The Event Center could also consider entering into agreements with the owners of nearby private lots to have guests park in those lots.
- It is recommended that a loading zone be striped in front of the Event Center for drop-offs and pick-ups. It is recommended that signs that read “No Parking, Loading Zone” be installed on the curb by the loading zone. Concept designs of the loading zone and the loading zone with parking are shown in Figures ES-1 and ES-2, respectively.
- Due to limited parking availability in Downtown Park City during peak days, it is recommended that Park City consider limiting the size of events based on time of year. Hales Engineering determined seasonal guest guideline limits based on seasonal traffic volumes and available parking. As determined in the Downtown and Main Street Parking Management Plan, there are approximately 150 stalls available on a winter peak day. Assuming 2 persons per vehicle, it was determined that the Event Center

could have an event with approximately 300 guests during peak months. Guest limits for other months were determined based off of this and seasonal adjustments. Higher limits were recommended for weekdays due to less traffic demand on weekday evenings. The recommended seasonal guest limits are shown in Table ES-1.

**Table ES-1: Recommended Seasonal Guest Limits**

Month	Day	
	Weekday	Weekend
January	350	300
February	400	350
March	400	350
April	480	480
May	480	480
June	425	400
July	350	300
August	375	325
September	425	400
October	450	450
November	480	480
December	400	350

- A park-and-ride facility has been discussed near Quinn’s junction. It is recommended that this park-and-ride lot be constructed to reduce the traffic and parking demand in Park City, therefore reducing vehicle-miles-traveled (VMT) and emissions.
  - If an additional park-and-ride facility is constructed near Quinn’s Junction and successfully reduces demand in the downtown core, the recommended guidelines shown in Table ES-1 could be adjusted to allow for higher guest limits.
  - The event center could also consider providing a shuttle from the Richardson Flats park-and-ride (or future Quinn’s Junction park-and-ride), or other mitigation methods, to obtain permits for a higher guest limit at larger events.
- It is recommended that Park City continue implementing the Downtown and Main Street Parking Management Plan.
- It is recommended that Event Center staff create a plan to clearly instruct guests regarding the location of the venue, where to park for events, and how to use the loading zone. This could be done with email, a website, fliers, guest invitations, maps, signing, etc., depending on the size and type of event.

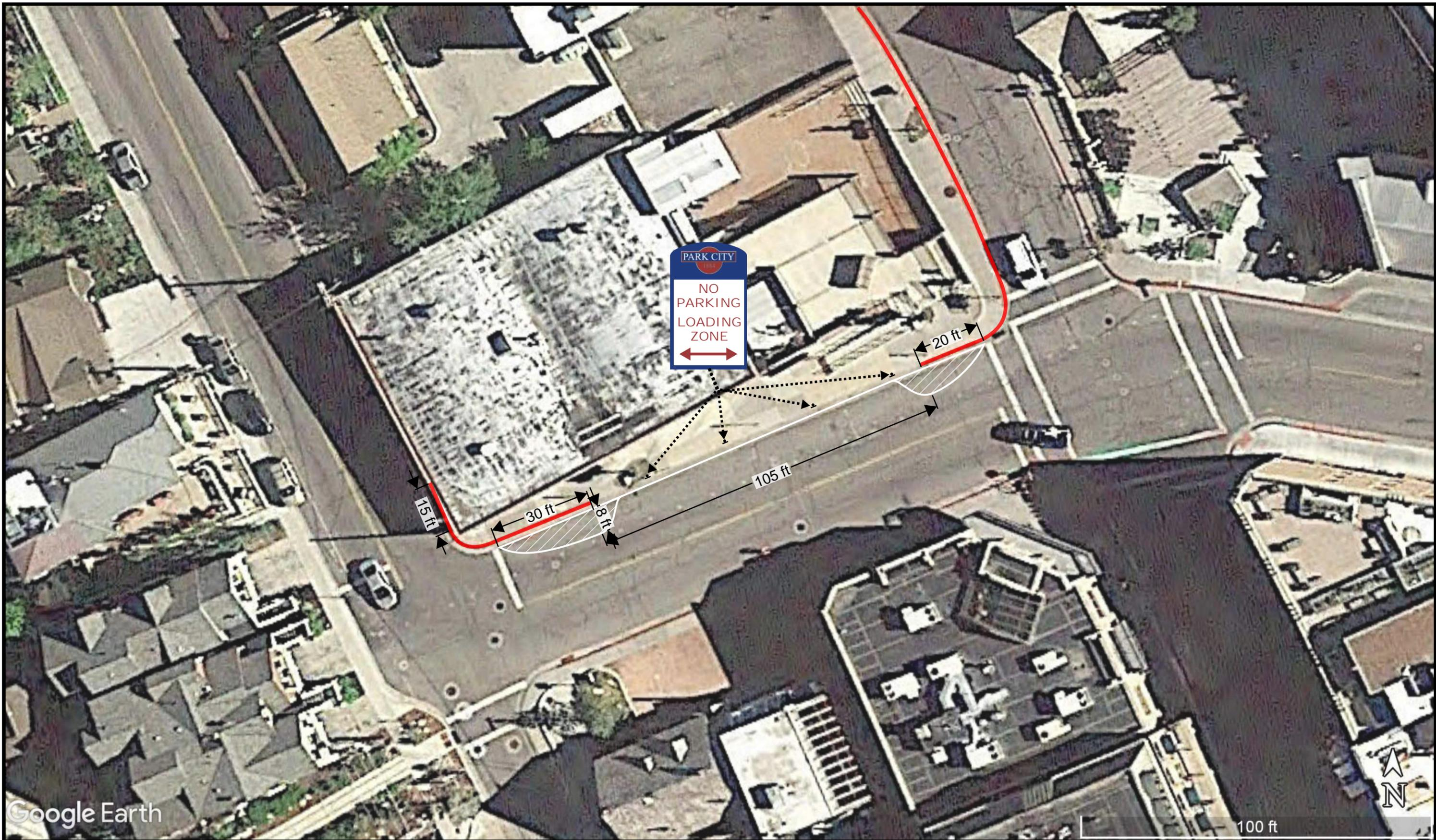

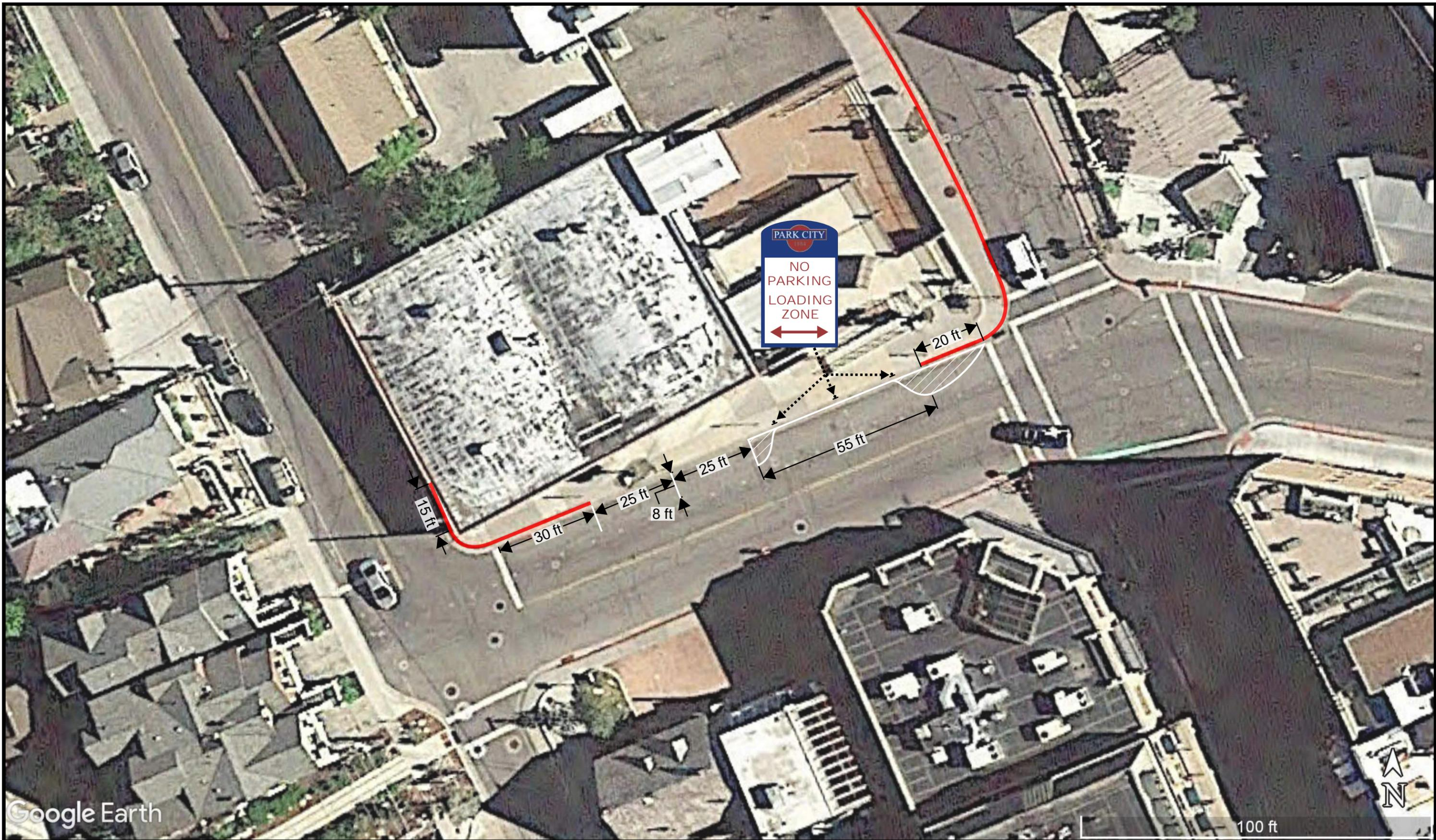

Google Earth

**TABLE OF CONTENTS**

**EXECUTIVE SUMMARY ..... i**

SUMMARY OF KEY FINDINGS/RECOMMENDATIONS..... i

**TABLE OF CONTENTS ..... v**

**LIST OF TABLES ..... vi**

**LIST OF FIGURES ..... vi**

**I. INTRODUCTION..... 1**

A. Purpose ..... 1

B. Project Description ..... 2

**II. EXISTING TRAFFIC AND PARKING ..... 3**

A. Data Collection ..... 3

B. Historical Data ..... 5

C. Parking ..... 7

D. Park City Code – On-street Parking ..... 9

E. Pedestrian Facilities ..... 10

**III. RECOMMENDATIONS ..... 11**

A. Event Center Parking ..... 11

B. Loading Zone ..... 11

C. Venue Capacity Limits ..... 14

D. Other Recommendations ..... 15

**Appendix A: Traffic Volume Counts**

**LIST OF TABLES**

Table 1: Monthly AADT Percentage ..... 5  
 Table 2: China Bridge Average Parking Demand..... 8  
 Table 3: China Bridge Parking Availability..... 9  
 Table 4: Recommended Seasonal Guest Limits ..... 14

**LIST OF FIGURES**

Figure 1: Vicinity map of project located in Park City, Utah..... 1  
 Figure 2: Event Center concept..... 2  
 Figure 3: Tube count locations and daily traffic volumes ..... 3  
 Figure 4: Time-of-day traffic volume distribution ..... 4  
 Figure 5: Peak hour turning movement counts - Sunday, July 22, 2018 ..... 5  
 Figure 6: SR-224 ADT history ..... 6  
 Figure 7: SR-248 ADT history ..... 6  
 Figure 8: Hourly parking occupancy by type of day (1) ..... 7  
 Figure 9: “No Parking, Loading Zone” signs..... 11  
 Figure 10: Recommendations concept design, option A ..... 12  
 Figure 11: Recommendations concept design, option B ..... 13

## I. INTRODUCTION

### A. Purpose

This report discusses the traffic study completed for the new Event Center in Park City, Utah. The Event Center will be located on the north side of Heber Avenue between Main Street and Park Avenue. A vicinity map of the project is shown in Figure 1. The purpose of the traffic study is to analyze existing traffic and parking patterns in the area, review the potential occupancy of the proposed Event Center, and discuss how people will travel to and from the Event Center.

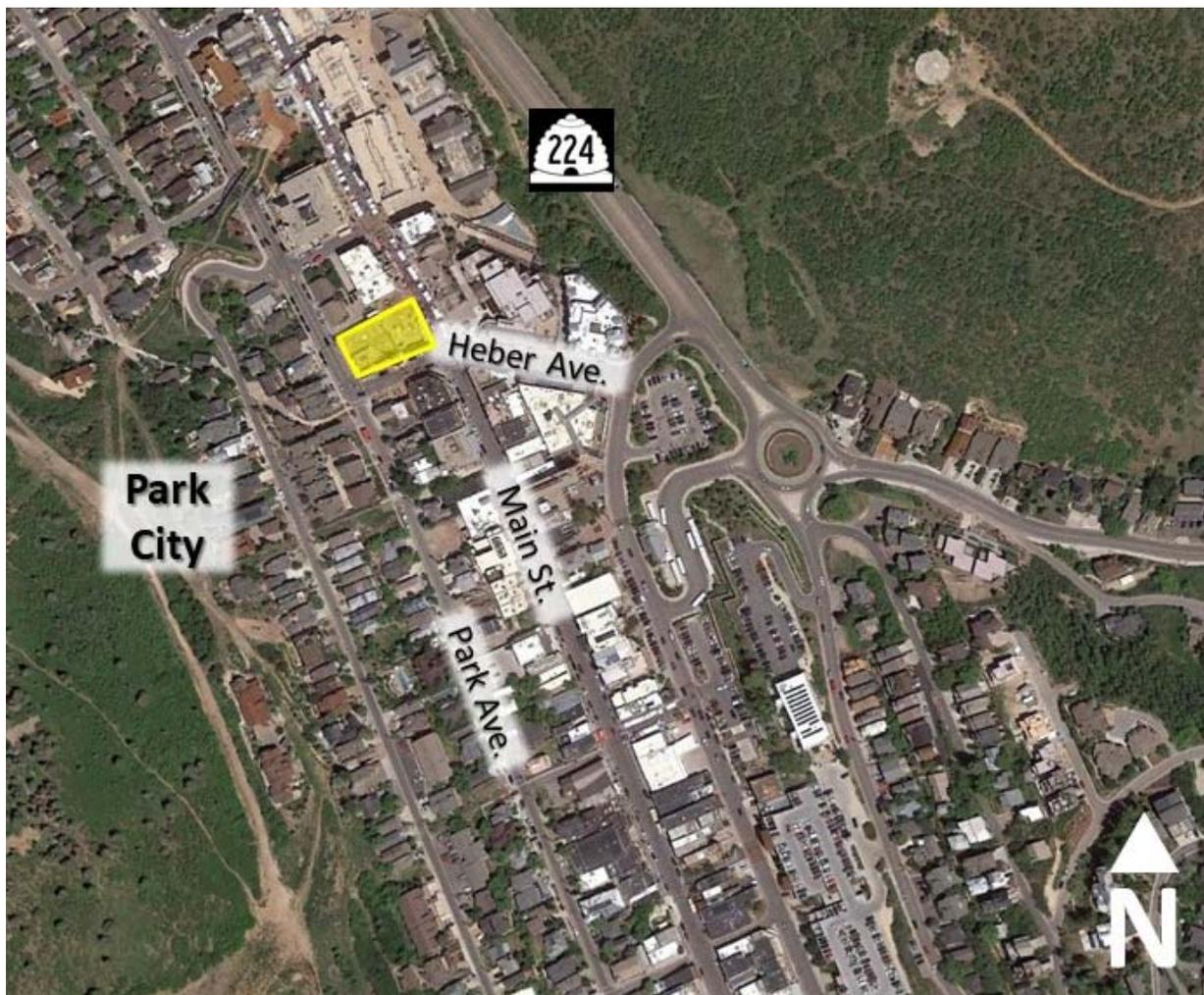

**Figure 1: Vicinity map of project located in Park City, Utah**

## **B. Project Description**

The new Event Center in Park City will be built adjacent to the former Kimball Art Center. A concept of the building is shown in Figure 2. The building will have two stories and will feature rentable space for events. It is anticipated that the maximum occupancy of the event space will be 480 people. According to Park City staff, a permit will be required for events with more than 250 guests. The Event Center will be located in downtown Park City close to shopping and restaurant locations, as well as several parking lots.



**Figure 2: Event Center concept**

## II. EXISTING TRAFFIC AND PARKING

### A. Data Collection

Hales Engineering collected traffic volume data near the project location over a 72-hour period. Roadway volumes were collected using pneumatic tube counters from Thursday, July 12 to Saturday, July 14 at the following four locations:

- Park Avenue, north of Heber Avenue
- Heber Avenue, east of Park Avenue
- Main Street, north of Heber Avenue
- Swede Alley, south of Heber Avenue

A map of these locations and the daily two-way traffic volumes at each is shown in Figure 3. As shown, traffic volumes were highest on Friday, July 13 at all four count locations. Swede Alley experienced the highest traffic volumes with at least 4,500 vehicles each day. The raw tube counts are provided in Appendix A.

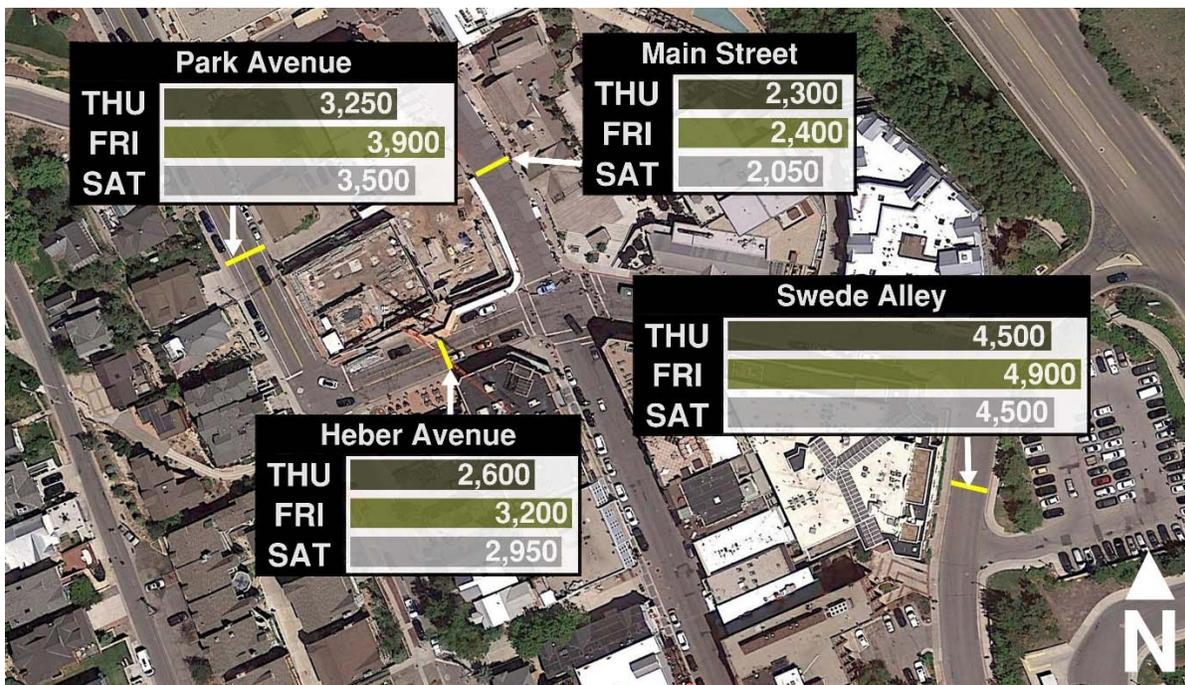
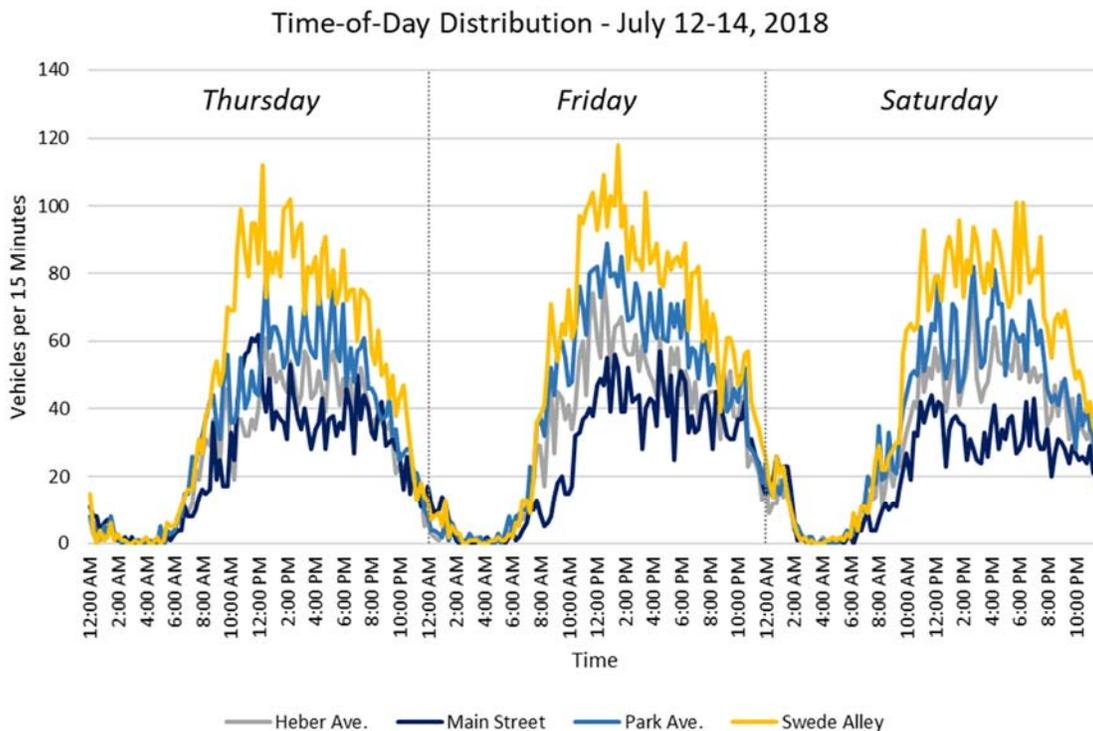

Figure 3: Tube count locations and daily traffic volumes

Hales Engineering analyzed the time-of-day distribution of the traffic volumes in the study area by summing the vehicles counted per 15-minute period at each tube count location. The resulting distribution is shown in Figure 4. As shown, the peak period on Thursday and Friday was observed during the lunch hour, or between 12:00 and 1:00 p.m. The peak period on Saturday was observed in the evening between 4:00 and 5:00 p.m.

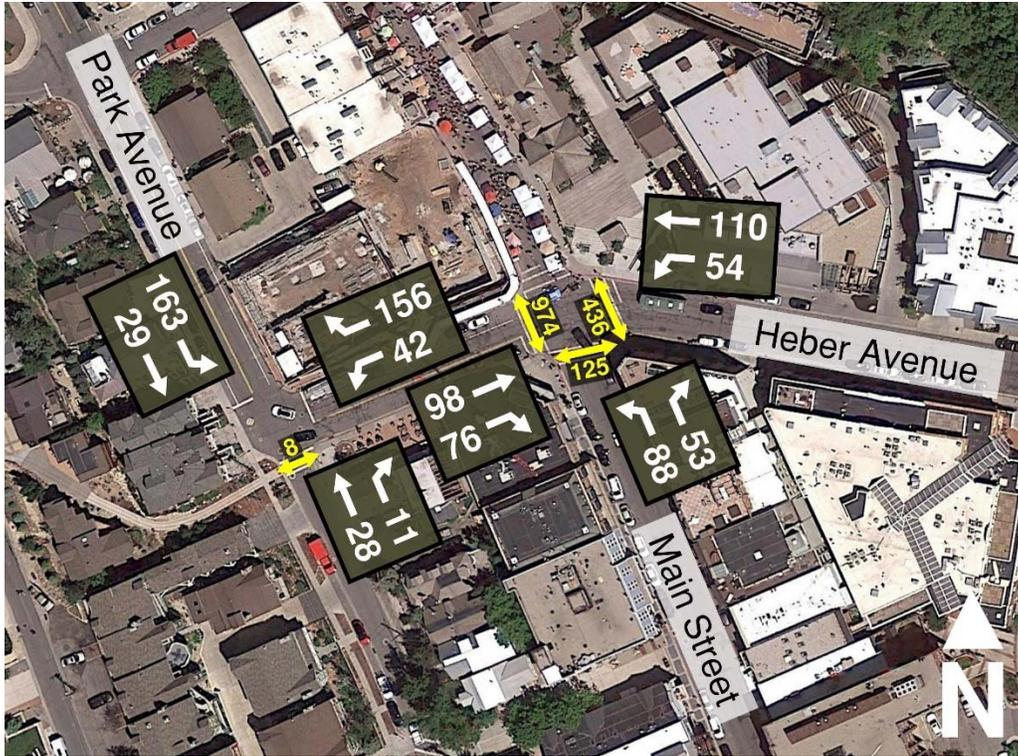

**Figure 4: Time-of-day traffic volume distribution**

Hales Engineering also collected turning movement counts at the following intersections:

- Park Avenue / Heber Avenue
- Main Street / Heber Avenue

These turning movement counts were collected on Sunday, July 22, 2018 from 4:00 to 6:00 p.m. based on the City’s request. The peak hour was determined to be between 5:00 and 6:00 p.m. at these locations. The southbound approach of the Main Street / Heber Avenue intersection was blocked off for the Park Silly Sunday Market, as it is most Sundays during the summer in Park City. A summary of the peak hour turning movement counts is shown in Figure 5 with pedestrian counts shown in yellow. Detailed count data is provided in Appendix A.



**Figure 5: Peak hour turning movement counts - Sunday, July 22, 2018**

**B. Historical Data**

Hales Engineering analyzed historic roadway volumes in the area to determine the seasonal trends in traffic volumes in Park City. This information is helpful to know the potential operation limits of the proposed Event Center. UDOT automatic traffic recorder (ATR) data was pulled from locations on SR-224 (near the Canyons Resort) and SR-248 (near Quinn’s Junction). A summary of the monthly ADT volumes relative to the annual average daily traffic (AADT) is shown in Table 1. As shown, January and July are winter and summer peak months, respectively. The lowest traffic volumes in the area are experienced in April and May.

**Table 1: Monthly AADT Percentage**

Roadway	Monthly Annual Average Daily Traffic (AADT) Percentage											
	Jan	Feb	Mar	Apr	May	Jun	Jul	Aug	Sep	Oct	Nov	Dec
SR-224	119%	113%	111%	82%	80%	97%	110%	107%	96%	90%	86%	109%
SR-248	108%	102%	102%	86%	88%	104%	112%	112%	101%	95%	87%	102%
Average	114%	107%	106%	84%	84%	100%	111%	110%	98%	92%	87%	105%

Visual representations of the average daily traffic (ADT) by month on these roadways between 2015 and 2017 is shown in Figure 6 and Figure 7, respectively. As shown, the recent monthly data reflects the previous findings that January and July are peak months and the lowest volumes are experienced in April and May.

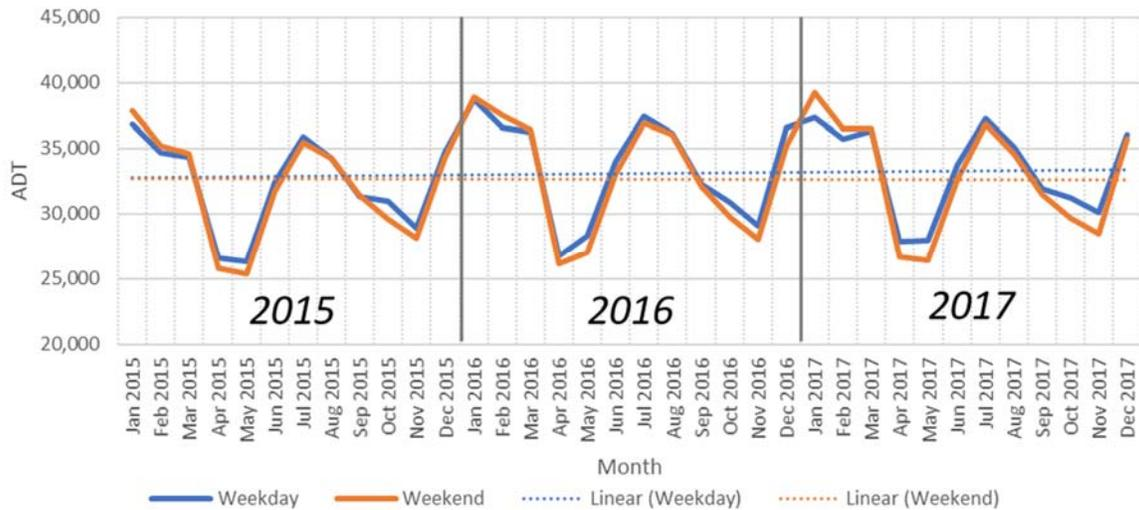

**Figure 6: SR-224 ADT history**

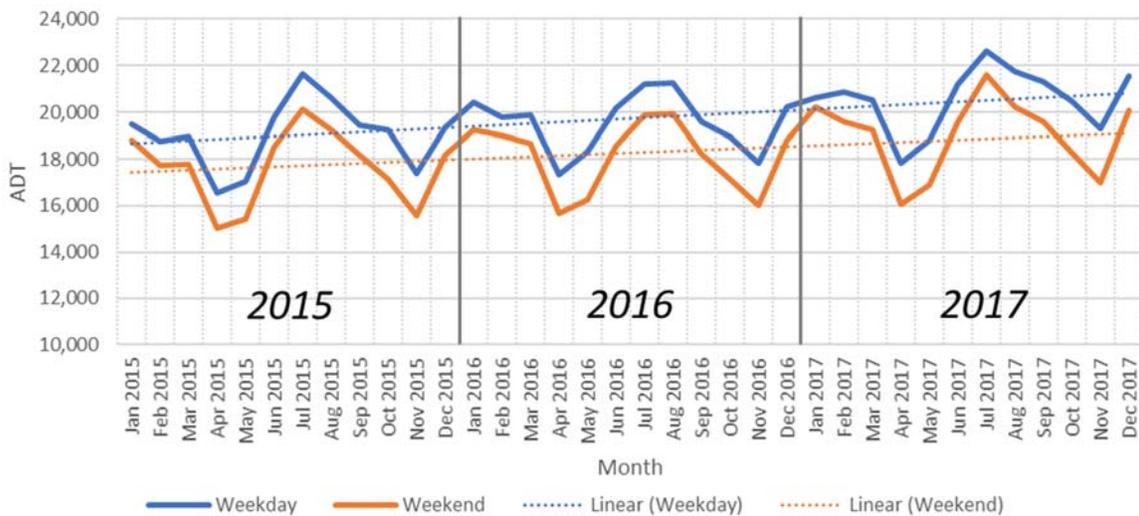

**Figure 7: SR-248 ADT history**

### C. Parking

Park City had a Downtown and Main Street Parking Management Plan completed by Nelson Nygaard in June 2016 (1). The plan reviewed Park City’s existing downtown parking facilities and policies and made recommendations to improve parking downtown and on Main Street. An extensive parking data collection effort was completed as part of the plan. The average hourly parking occupancy in the downtown area by type of day is shown in Figure 8. As shown, there is excess parking throughout the day in the downtown area, even on busy peak days. Parking occupancy generally increases in the evening on all days except for weekdays. In the data collection efforts on peak days, it was observed that most of the available parking in the evening was available on the street, as most of the parking lots were close to or at capacity.

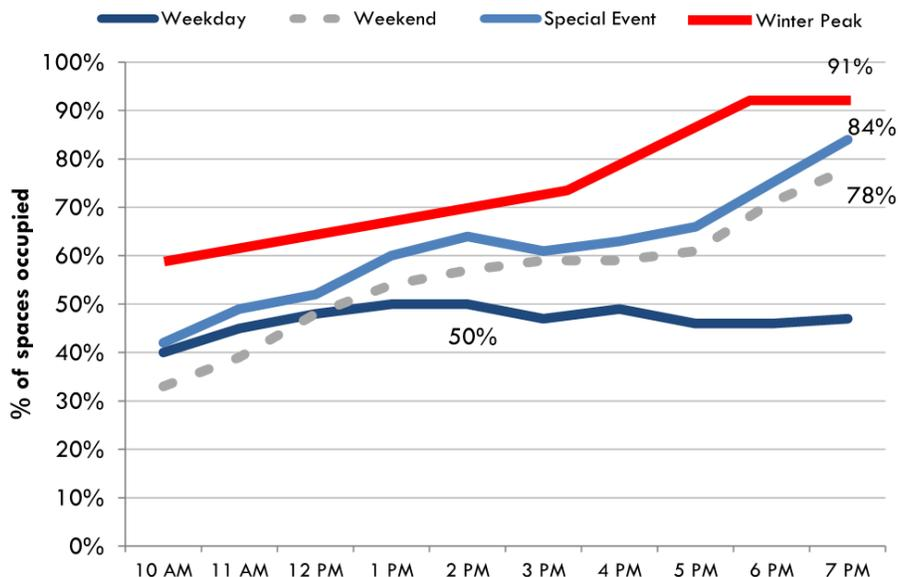

**Figure 8: Hourly parking occupancy by type of day (1)**

Several recommendations were given in the Downtown and Main Street Parking Management Plan to improve parking in the area. These included upgrading parking signage and wayfinding. Other recommendations included upgrading online parking services and information to improve communication with drivers. Hales Engineering echoes the recommendations listed in the parking management plan. It is anticipated that these improvements will help inform the public and satisfy parking demand in the downtown area.

<sup>1</sup> “Downtown and Main Street Parking Management Plan.” Nelson\Nygaard Consulting Associates Inc. June 2016. Park City Municipal Corporation.

Park City provided Hales Engineering with recent parking data from the China Bridge parking structure. The China Bridge parking structure is located between Swede Alley and Marsac Avenue and has 575 parking stalls. China Bridge is a popular parking location due to its proximity to Main Street and because it is free during the daytime. Vehicles parking there after 5:00 p.m. are charged after one hour of being parked. Park City has loop sensors at the entrances and exits of the parking structure that detect vehicles as they enter and exit the parking area.

Park City staff provided parking data from February 1, 2018 to August 21, 2018 at China Bridge between 3:00 and 11:00 p.m. on each day. Data was missing for some hours and some entire days, including Independence Day weekend. Overall, data for 195 days was provided. The data were summarized by season to show the average parking demand by hour on weekdays and Saturdays. A summary of this data is shown in Table 2.

As shown, average parking demand is generally higher on weekends than on weekdays. The parking demands are high in the winter and summer, with winter having higher evening demand. Parking demand is much lower in the spring. These seasonal trends correspond with the observed historical traffic volumes observed on SR-224 and SR-248.

**Table 2: China Bridge Average Parking Demand**

Time	Winter (Feb. - Apr.)		Spring (Apr. - May)		Summer (Jun. - Aug.)	
	Weekday	Weekend*	Weekday	Weekend*	Weekday	Weekend*
3:00 PM	347	362	240	200	298	375
4:00 PM	318	323	220	188	270	311
5:00 PM	280	289	191	165	232	273
6:00 PM	238	322	133	139	176	248
7:00 PM	251	351	89	143	170	295
8:00 PM	275	367	86	152	178	343
9:00 PM	259	363	87	158	151	258
10:00 PM	217	299	60	124	118	201
11:00 PM	200	269	54	64	75	119

Weekend \* = Only Saturday

Hales Engineering analyzed the available China Bridge data to see what size of event could be supported by the China Bridge parking structure. As shown in Table 3, approximately 72 percent of the observed days had a minimum unoccupied stall count of at least 240 stalls. Assuming that there are 2 people per car, the China Bridge structure could support an event with 480 people approximately 72% of the time, based on the observed days. Approximately 28 percent of the days, the China Bridge structure may not be able to support an event of 480 alone. However, parking may be found elsewhere on those days. If not, a smaller event would be necessary.

**Table 3: China Bridge Parking Availability**

Scenario	Days	%
Total Days	195	
Days with > 240 Unoccupied Stalls	140	72%
Days with 125-240 Unoccupied Stalls	41	21%
Days with < 125 Unoccupied Stalls	14	7%

**D. Park City Code – On-street Parking**

Hales Engineering reviewed the existing parking on the block surrounding the Event Center to determine if it is compliant with City standards and code. The Park City Municipal Code states the following requirements in Section 9:

- (9-2-1) “It shall be unlawful and a violation of this Title for any person to park a vehicle, or to permit others to park a vehicle in any of the following places on a street or public parking facility:”
  - “In front of, or within five feet (5') of a public or private driveway or alleyway;”
  - “Within an intersection, or within fifteen feet (15') of an intersection;”
  - “Within twenty feet (20') of a crosswalk;”
  - “Within thirty feet (30') from the approach to any...traffic control device, including stop signs controlling traffic on the same roadway as the approach;”

Hales Engineering visited the study site on June 29, 2018 and observed parking conditions. It was observed that the parking areas surrounding the Event Center block were in compliance with the City code for the most part. It was observed that the curb adjacent to the project site was not red-curbed. However, there were temporary “no parking” signs near the intersections and along the west side of Main Street to prohibit parking. It is recommended that the curb be painted red at the corners of the study intersections at least 15 feet from the intersections, at least 20 feet from the crosswalk, and 30 feet from stop signs. By restricting parking near the intersection corners, sight distance will be improved, and large vehicles will have more room to make turns at the intersection.

It was observed that parking is allowed on the east side of Main Street but not on the west side. Temporary “no parking” signs are currently on the west side while construction continues on the Event Center. Main Street has a width of approximately 30 feet in the study area. A vehicle generally needs between 6 and 8 feet of parking width for on-street parking. With parking on just the east side of the street, there would be between 22 and 24 feet for travel lanes, which is just enough for one lane in each direction. Therefore, it is recommended that the west side of Main Street be red-curbed between Heber Avenue and 7<sup>th</sup> Street.

## **E. Pedestrian Facilities**

Hales Engineering also analyzed the existing pedestrian facilities that would be used by guests at the Event Center. Park City is known for its walkable streets and pedestrian-friendly facilities. Main Street in particular is lined with wide sidewalks for pedestrians. The roadway has features that act as traffic calming measures including on-street parking on both sides of the street, side-street dining locations, and curb bulb-outs at mid-block crosswalks. These features slow vehicles down and create a safe walking environment for pedestrians. Based on these characteristics, it is anticipated that there are adequate pedestrian facilities in the study area that provide a safe option for guests to walk to and from the Event Center.

### III. RECOMMENDATIONS

#### A. Event Center Parking

As was discussed in the Park City Downtown and Main Street Parking Management Plan, Park City has parking throughout the downtown area in the form of both off-street and on-street parking. Because the proposed Event Center project does not include on-site parking, guests will park in one of the many parking locations in Park City Downtown.

It is anticipated that many guests will park in the public parking lots east of Swede Alley such as the North Marsac lot, the Bob Wells lots, the China Bridge lots, or the Sandridge Lots. It is anticipated that these parking lots will meet the needs of Event Center guests. Guests can also choose from other parking areas based on availability. There are a few privately-owned parking lots north of the Event Center site. The Event Center could consider entering into agreements with the owners of these lots to have guests park in those lots.

#### B. Loading Zone

It is recommended that a loading zone be striped in front of the Event Center for drop-offs and pick-ups. With parking being restricted near the intersections, there is approximately 105 feet along the curb for parking and the loading zone. This space could be used for a loading zone and some parking, or all for a loading zone. It is recommended that signs that read “No Parking, Loading Zone” be installed on the curb by the loading zone. Examples of a standard sign of this type and a City-themed sign are shown in Figure 9. Hales Engineering designed concepts of this improvement, one with two parking stalls and one without. These are shown in Figure 10 and Figure 11.



Figure 9: “No Parking, Loading Zone” signs

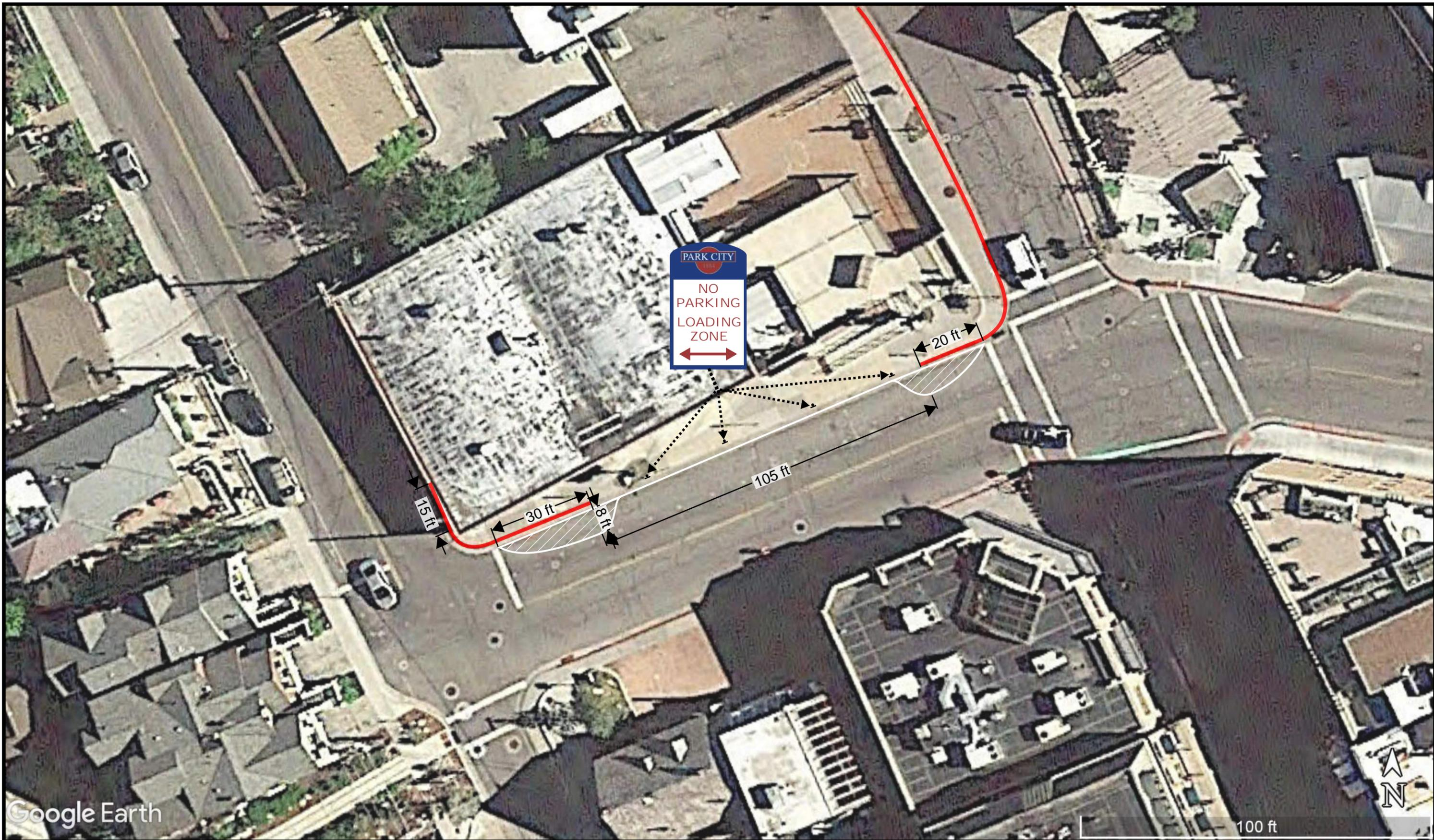

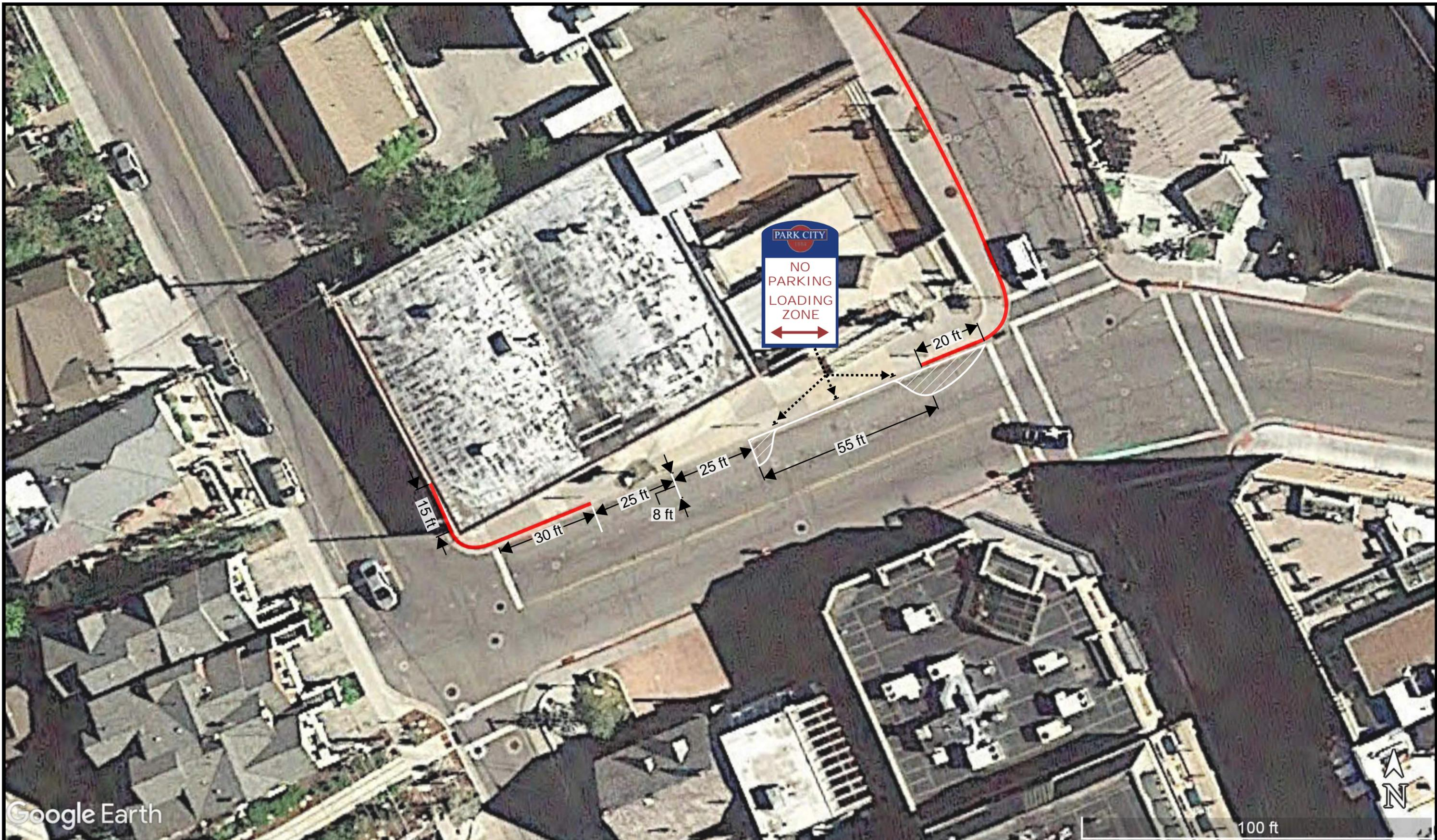

**C. Venue Capacity Limits**

Due to limited parking availability in Downtown Park City during peak days, it is recommended that Park City limit the size of events based on time of year. As discussed, the maximum occupancy of the Event Center is anticipated to be 480 people. According to City staff, it is any event with more than 250 guests will be required to have a permit through the City.

In order to guide the City in reviewing event permit applications, Hales Engineering estimated guest limits based on the historical traffic volumes and China Bridge parking data presented in Chapter II. The limits were based on seasonal and daily traffic volume and parking variations. Busy months were assigned lower limits due to limited parking, and low months were assigned high limits equal to the building occupancy. Weekday event limits were assigned higher values because weekdays have peaks earlier in the day.

Based on the Downtown and Main Street Parking Management Plan, there are approximately 1,690 parking stalls in the downtown area and 91% of those are occupied during the winter peak. This leaves approximately 150 unoccupied stalls that could be used by the Event Center. Assuming vehicles have an occupancy of 2 persons per vehicle, it is anticipated that the remaining parking during peak times could support an event with approximately 300 guests. This was assumed to be the guest limit for a weekend event during peak months and other limits were determined based on this value and seasonal adjustments. The recommended seasonal guest limits are shown in Table 4.

**Table 4: Recommended Seasonal Guest Limits**

Month	Day	
	Weekday	Weekend
January	350	300
February	400	350
March	400	350
April	480	480
May	480	480
June	425	400
July	350	300
August	375	325
September	425	400
October	450	450
November	480	480
December	400	350

Park City staff may use these values as a guide when reviewing permit applications. However, it is anticipated that the approved guest quantity may vary based on other factors or events occurring in Park City on the day of the planned event or other factors that might increase or decrease traffic and parking demand in the area.

#### **D. Other Recommendations**

Park City has made several recent improvements to the City transportation system, making it easier for residents and guests to get around. These improvements include park-and-ride lots, transit facilities, and shared electric bike programs. Another potential transit improvement that is proposed is the construction of a park-and-ride lot near Quinn's Junction and the SR-248 / US-40 interchange for guests in the Park City area. It is recommended that the park-and-ride lot be installed to reduce the traffic and parking demand in Park City, therefore reducing vehicle-miles-traveled (VMT) and emissions.

If an additional park-and-ride facility is constructed near Quinn's Junction and successfully reduces demand in the downtown core, the recommended guidelines shown in Table 4 could be adjusted to allow for higher guest limits.

The event center could also consider providing a shuttle from the Richardson Flats park-and-ride (or future Quinn's Junction park-and-ride), or other mitigation methods, to obtain permits for a higher guest limit at larger events.

As discussed, the Downtown and Main Street Parking Management Plan discusses several recommendations for parking in Park City. It is recommended that Park City continue implementing this plan.

It is also recommended that Event Center staff create a plan to clearly instruct guests regarding the location of the venue, where to park for events, and how to use the loading zone. This could be done with email, a website, fliers, guest invitations, maps, signing, etc., depending on the size and type of event. By instructing guests about this prior to the event, there will be less confusion, and traffic congestion near the venue may be reduced by routing guests directly to parking areas instead of the Event Center. It is also recommended that the Event Center instruct guests to not park in nearby neighborhoods.

# APPENDIX A

## Traffic Volume Counts

## Intersection Turning Movement Summary

Intersection: Main Street / Heber Avenue  
North/South: Main Street  
East/West: Heber Avenue  
Jurisdiction: Park City  
Project Title: Event Center TS  
Project No: 1279  
Weather: Clear

Date: 7-22-18, Sun  
Day of Week Adjustment: 100.0%  
Month of Year Adjustment: 100.0%  
Adjustment Station #: 0  
Growth Rate: 0.0%  
Number of Years: 0

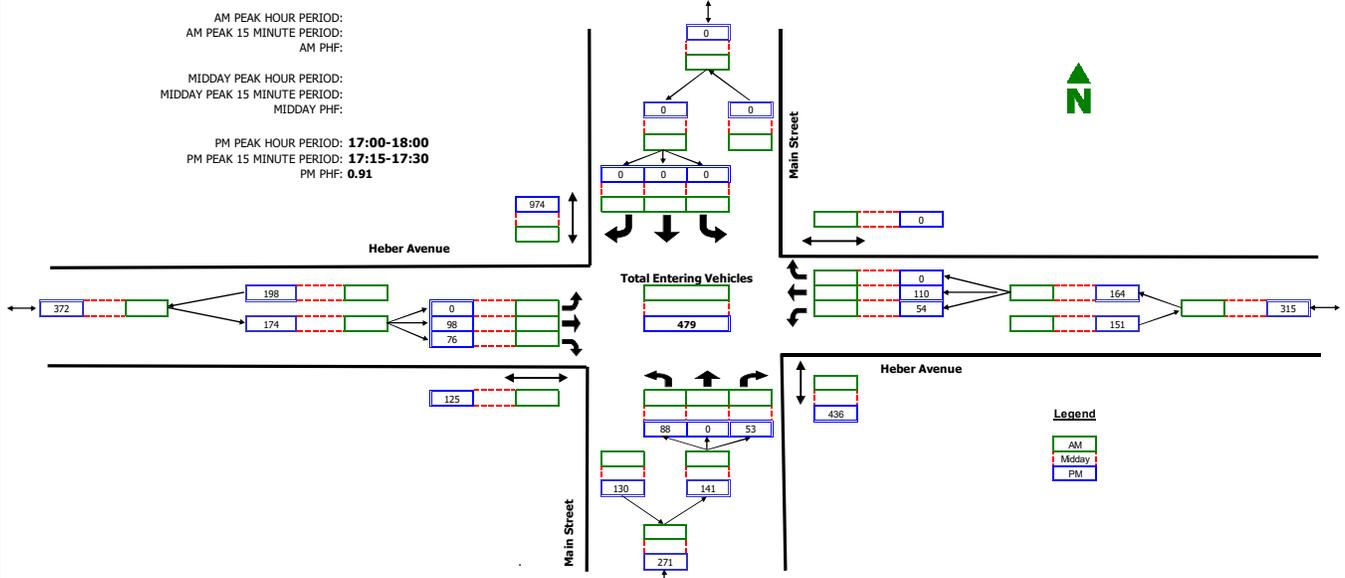

RAW COUNT SUMMARIES	Main Street Northbound				Main Street Southbound				Heber Avenue Eastbound				Heber Avenue Westbound				TOTAL
	A	B	C	D	E	F	G	H	I	J	K	L	M	N	O	P	
<b>AM PERIOD COUNTS</b>																	
Period	A	B	C	D	E	F	G	H	I	J	K	L	M	N	O	P	TOTAL
7:00-7:15	0	0	0	0	0	0	0	0	0	0	0	0	0	0	0	0	0
7:15-7:30	0	0	0	0	0	0	0	0	0	0	0	0	0	0	0	0	0
7:30-7:45	0	0	0	0	0	0	0	0	0	0	0	0	0	0	0	0	0
7:45-8:00	0	0	0	0	0	0	0	0	0	0	0	0	0	0	0	0	0
8:00-8:15	0	0	0	0	0	0	0	0	0	0	0	0	0	0	0	0	0
8:15-8:30	0	0	0	0	0	0	0	0	0	0	0	0	0	0	0	0	0
8:30-8:45	0	0	0	0	0	0	0	0	0	0	0	0	0	0	0	0	0
8:45-9:00	0	0	0	0	0	0	0	0	0	0	0	0	0	0	0	0	0
<b>MIDDAY PERIOD COUNTS</b>																	
Period	A	B	C	D	E	F	G	H	I	J	K	L	M	N	O	P	TOTAL
9:00-9:15	0	0	0	0	0	0	0	0	0	0	0	0	0	0	0	0	0
9:15-9:30	0	0	0	0	0	0	0	0	0	0	0	0	0	0	0	0	0
9:30-9:45	0	0	0	0	0	0	0	0	0	0	0	0	0	0	0	0	0
9:45-10:00	0	0	0	0	0	0	0	0	0	0	0	0	0	0	0	0	0
10:00-10:15	0	0	0	0	0	0	0	0	0	0	0	0	0	0	0	0	0
10:15-10:30	0	0	0	0	0	0	0	0	0	0	0	0	0	0	0	0	0
10:30-10:45	0	0	0	0	0	0	0	0	0	0	0	0	0	0	0	0	0
10:45-11:00	0	0	0	0	0	0	0	0	0	0	0	0	0	0	0	0	0
11:00-11:15	0	0	0	0	0	0	0	0	0	0	0	0	0	0	0	0	0
11:15-11:30	0	0	0	0	0	0	0	0	0	0	0	0	0	0	0	0	0
11:30-11:45	0	0	0	0	0	0	0	0	0	0	0	0	0	0	0	0	0
11:45-12:00	0	0	0	0	0	0	0	0	0	0	0	0	0	0	0	0	0
12:00-12:15	0	0	0	0	0	0	0	0	0	0	0	0	0	0	0	0	0
12:15-12:30	0	0	0	0	0	0	0	0	0	0	0	0	0	0	0	0	0
12:30-12:45	0	0	0	0	0	0	0	0	0	0	0	0	0	0	0	0	0
12:45-13:00	0	0	0	0	0	0	0	0	0	0	0	0	0	0	0	0	0
13:00-13:15	0	0	0	0	0	0	0	0	0	0	0	0	0	0	0	0	0
13:15-13:30	0	0	0	0	0	0	0	0	0	0	0	0	0	0	0	0	0
13:30-13:45	0	0	0	0	0	0	0	0	0	0	0	0	0	0	0	0	0
13:45-14:00	0	0	0	0	0	0	0	0	0	0	0	0	0	0	0	0	0
14:00-14:15	0	0	0	0	0	0	0	0	0	0	0	0	0	0	0	0	0
14:15-14:30	0	0	0	0	0	0	0	0	0	0	0	0	0	0	0	0	0
14:30-14:45	0	0	0	0	0	0	0	0	0	0	0	0	0	0	0	0	0
14:45-15:00	0	0	0	0	0	0	0	0	0	0	0	0	0	0	0	0	0
15:00-15:15	0	0	0	0	0	0	0	0	0	0	0	0	0	0	0	0	0
15:15-15:30	0	0	0	0	0	0	0	0	0	0	0	0	0	0	0	0	0
15:30-15:45	0	0	0	0	0	0	0	0	0	0	0	0	0	0	0	0	0
15:45-16:00	0	0	0	0	0	0	0	0	0	0	0	0	0	0	0	0	0
<b>PM PERIOD COUNTS</b>																	
Period	A	B	C	D	E	F	G	H	I	J	K	L	M	N	O	P	TOTAL
16:00-16:15	15	0	10	299	0	0	0	375	0	24	23	28	9	27	0	0	106
16:15-16:30	16	0	9	319	0	0	0	411	0	31	13	27	11	24	0	0	104
16:30-16:45	13	0	18	145	0	0	0	381	0	11	15	63	17	25	0	0	99
16:45-17:00	18	0	19	167	0	0	0	340	0	19	15	43	6	27	0	0	104
17:00-17:15	26	0	12	155	0	0	0	339	0	30	17	44	4	32	0	0	121
17:15-17:30	24	0	18	147	0	0	0	323	0	23	14	44	25	27	0	0	131
17:30-17:45	22	0	13	104	0	0	0	191	0	21	25	21	9	26	0	0	116
17:45-18:00	16	0	10	30	0	0	0	121	0	24	20	16	16	25	0	0	111

## Intersection Turning Movement Summary

Intersection: Park Avenue / Heber Avenue  
North/South: Park Avenue  
East/West: Heber Avenue  
Jurisdiction: Park City  
Project Title: Event Center TS  
Project No: 1279  
Weather: Clear

Date: 7-22-18, Sun  
Day of Week Adjustment: 100.0%  
Month of Year Adjustment: 100.0%  
Adjustment Station #: 0  
Growth Rate: 0.0%  
Number of Years: 0

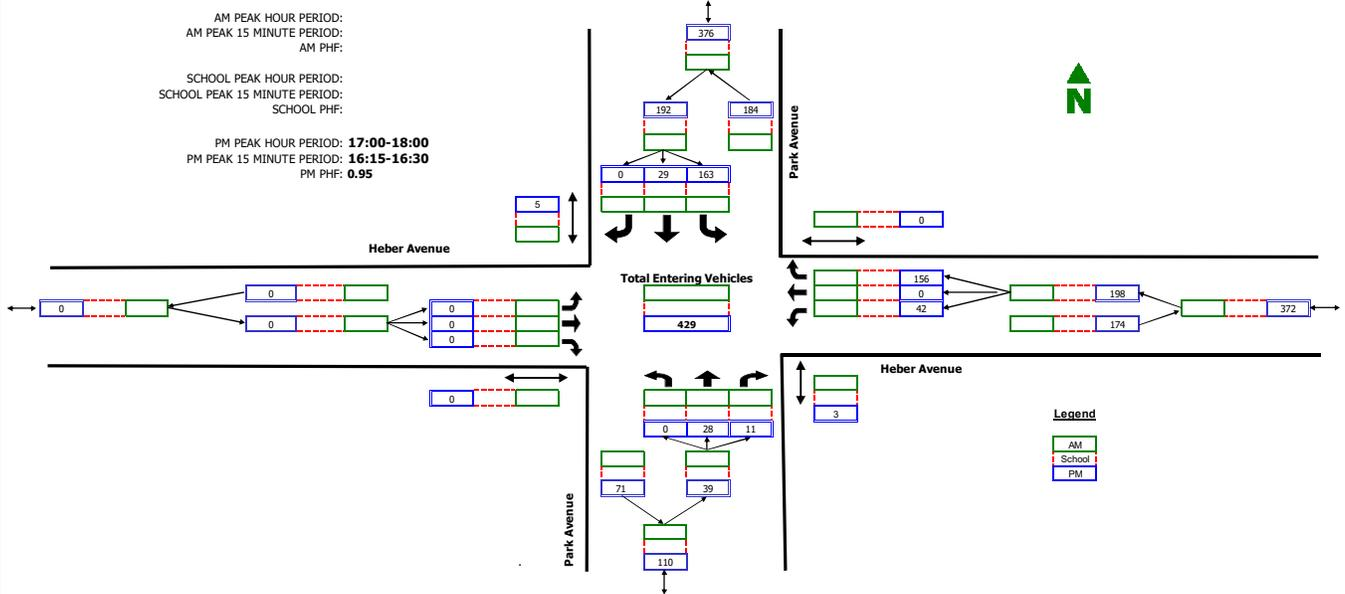

RAW COUNT SUMMARIES	Park Avenue Northbound				Park Avenue Southbound				Heber Avenue Eastbound				Heber Avenue Westbound				TOTAL
	Left	Thru	Right	Peds	Left	Thru	Right	Peds	Left	Thru	Right	Peds	Left	Thru	Right	Peds	
<b>AM PERIOD COUNTS</b>																	
Period	A	B	C	D	E	F	G	H	I	J	K	L	M	N	O	P	TOTAL
7:00-7:15	0	0	0	0	0	0	0	0	0	0	0	0	0	0	0	0	0
7:15-7:30	0	0	0	0	0	0	0	0	0	0	0	0	0	0	0	0	0
7:30-7:45	0	0	0	0	0	0	0	0	0	0	0	0	0	0	0	0	0
7:45-8:00	0	0	0	0	0	0	0	0	0	0	0	0	0	0	0	0	0
8:00-8:15	0	0	0	0	0	0	0	0	0	0	0	0	0	0	0	0	0
8:15-8:30	0	0	0	0	0	0	0	0	0	0	0	0	0	0	0	0	0
8:30-8:45	0	0	0	0	0	0	0	0	0	0	0	0	0	0	0	0	0
8:45-9:00	0	0	0	0	0	0	0	0	0	0	0	0	0	0	0	0	0
<b>MIDDAY PERIOD COUNTS</b>																	
Period	A	B	C	D	E	F	G	H	I	J	K	L	M	N	O	P	TOTAL
9:00-9:15	0	0	0	0	0	0	0	0	0	0	0	0	0	0	0	0	0
9:15-9:30	0	0	0	0	0	0	0	0	0	0	0	0	0	0	0	0	0
9:30-9:45	0	0	0	0	0	0	0	0	0	0	0	0	0	0	0	0	0
9:45-10:00	0	0	0	0	0	0	0	0	0	0	0	0	0	0	0	0	0
10:00-10:15	0	0	0	0	0	0	0	0	0	0	0	0	0	0	0	0	0
10:15-10:30	0	0	0	0	0	0	0	0	0	0	0	0	0	0	0	0	0
10:30-10:45	0	0	0	0	0	0	0	0	0	0	0	0	0	0	0	0	0
10:45-11:00	0	0	0	0	0	0	0	0	0	0	0	0	0	0	0	0	0
11:00-11:15	0	0	0	0	0	0	0	0	0	0	0	0	0	0	0	0	0
11:15-11:30	0	0	0	0	0	0	0	0	0	0	0	0	0	0	0	0	0
11:30-11:45	0	0	0	0	0	0	0	0	0	0	0	0	0	0	0	0	0
11:45-12:00	0	0	0	0	0	0	0	0	0	0	0	0	0	0	0	0	0
12:00-12:15	0	0	0	0	0	0	0	0	0	0	0	0	0	0	0	0	0
12:15-12:30	0	0	0	0	0	0	0	0	0	0	0	0	0	0	0	0	0
12:30-12:45	0	0	0	0	0	0	0	0	0	0	0	0	0	0	0	0	0
12:45-13:00	0	0	0	0	0	0	0	0	0	0	0	0	0	0	0	0	0
13:00-13:15	0	0	0	0	0	0	0	0	0	0	0	0	0	0	0	0	0
13:15-13:30	0	0	0	0	0	0	0	0	0	0	0	0	0	0	0	0	0
13:30-13:45	0	0	0	0	0	0	0	0	0	0	0	0	0	0	0	0	0
13:45-14:00	0	0	0	0	0	0	0	0	0	0	0	0	0	0	0	0	0
14:00-14:15	0	0	0	0	0	0	0	0	0	0	0	0	0	0	0	0	0
14:15-14:30	0	0	0	0	0	0	0	0	0	0	0	0	0	0	0	0	0
14:30-14:45	0	0	0	0	0	0	0	0	0	0	0	0	0	0	0	0	0
14:45-15:00	0	0	0	0	0	0	0	0	0	0	0	0	0	0	0	0	0
15:00-15:15	0	0	0	0	0	0	0	0	0	0	0	0	0	0	0	0	0
15:15-15:30	0	0	0	0	0	0	0	0	0	0	0	0	0	0	0	0	0
15:30-15:45	0	0	0	0	0	0	0	0	0	0	0	0	0	0	0	0	0
15:45-16:00	0	0	0	0	0	0	0	0	0	0	0	0	0	0	0	0	0
<b>PM PERIOD COUNTS</b>																	
Period	A	B	C	D	E	F	G	H	I	J	K	L	M	N	O	P	TOTAL
16:00-16:15	0	7	3	11	52	6	0	0	0	0	0	0	3	0	35	0	106
16:15-16:30	0	11	0	0	52	7	0	5	0	0	0	0	6	0	37	0	113
16:30-16:45	0	8	0	14	39	7	0	2	0	0	0	0	7	0	30	0	91
16:45-17:00	1	3	7	0	28	2	0	1	0	0	0	0	11	0	28	0	80
17:00-17:15	0	8	5	3	37	4	0	2	0	0	0	0	13	0	42	0	109
17:15-17:30	0	11	3	0	34	10	0	3	0	0	0	0	12	0	38	0	108
17:30-17:45	0	1	1	0	46	5	0	0	0	0	0	0	9	0	42	0	104
17:45-18:00	0	8	2	0	46	10	0	0	0	0	0	0	8	0	34	0	108

## Daily Vehicle Volume Report

Study Date: Thursday, 07/12/2018

Unit ID:

Location: Swede Alley

	Northbound olume	Southbound olume	Total olume
00:00 - 00:	19	4	23
01:00 - 01:	8	2	10
02:00 - 02:	4	1	
03:00 - 03:	1	1	2
04:00 - 04:	0	4	4
0 :00 - 0 :	3	9	12
06:00 - 06:	15	23	38
0 :00 - 0 :	31	56	8
08:00 - 08:	51	105	1 6
0 :00 - 0 :	69	153	222
10:00 - 10:	121	204	32
11:00 - 11:	152	203	3
12:00 - 12:	154	200	3 4
13:00 - 13:	140	204	344
14:00 - 14:	184	196	380
1 :00 - 1 :	153	172	32
16:00 - 16:	160	174	334
1 :00 - 1 :	143	157	300
18:00 - 18:	108	201	30
1 :00 - 1 :	111	170	281
20:00 - 20:	126	97	223
21:00 - 21:	116	68	184
22:00 - 22:	107	50	1
23:00 - 23:	45	21	66
<b>Totals</b>	<b>2021</b>	<b>24</b>	<b>44 6</b>
<b>AM Peak Time</b>	<b>10: 8 - 11:</b>	<b>10:38 - 11:3</b>	<b>10:48 - 11:4</b>
<b>AM Peak olume</b>	<b>1 2</b>	<b>221</b>	<b>362</b>
<b>PM Peak Time</b>	<b>14:12 - 1 :11</b>	<b>13:34 - 14:33</b>	<b>13:43 - 14:42</b>
<b>PM Peak olume</b>	<b>1 2</b>	<b>21</b>	<b>38</b>

## Daily Vehicle Volume Report

Study Date: Friday, 07/13/2018

Unit ID:

Location: Swede Alley

	Northbound olume	Southbound olume	Total olume
00:00 - 00:	22	15	3
01:00 - 01:	16	9	2
02:00 - 02:	5	1	6
03:00 - 03:	2	1	3
04:00 - 04:	0	2	2
0 :00 - 0 :	2	5	
06:00 - 06:	4	22	26
0 :00 - 0 :	15	62	
08:00 - 08:	56	148	204
0 :00 - 0 :	73	169	242
10:00 - 10:	104	193	2
11:00 - 11:	142	257	3
12:00 - 12:	140	256	3 6
13:00 - 13:	187	228	41
14:00 - 14:	181	178	3
1 :00 - 1 :	133	219	3 2
16:00 - 16:	163	164	32
1 :00 - 1 :	130	206	336
18:00 - 18:	119	195	314
1 :00 - 1 :	115	179	2 4
20:00 - 20:	96	131	22
21:00 - 21:	129	101	230
22:00 - 22:	115	94	20
23:00 - 23:	97	45	142
<b>Totals</b>	<b>2046</b>	<b>2880</b>	<b>4 26</b>
<b>AM Peak Time</b>	<b>10: 3 - 11: 2</b>	<b>10: - 11: 6</b>	<b>10: 6 - 11:</b>
<b>AM Peak olume</b>	<b>14</b>	<b>262</b>	<b>40</b>
<b>PM Peak Time</b>	<b>13:2 - 14:24</b>	<b>12:01 - 13:00</b>	<b>12: - 13: 8</b>
<b>PM Peak olume</b>	<b>201</b>	<b>2 8</b>	<b>421</b>

## Daily Vehicle Volume Report

Study Date: Saturday, 07/14/2018

Unit ID:

Location: Swede Alley

	Northbound olume	Southbound olume	Total olume
00:00 - 00:	60	25	8
01:00 - 01:	49	19	68
02:00 - 02:	9	3	12
03:00 - 03:	1	0	1
04:00 - 04:	1	3	4
0 :00 - 0 :	5	2	
06:00 - 06:	8	18	26
0 :00 - 0 :	21	38	
08:00 - 08:	34	65	
0 :00 - 0 :	45	99	144
10:00 - 10:	66	189	2
11:00 - 11:	115	202	31
12:00 - 12:	135	182	31
13:00 - 13:	145	203	348
14:00 - 14:	130	201	331
1 :00 - 1 :	131	195	326
16:00 - 16:	135	206	341
1 :00 - 1 :	117	203	320
18:00 - 18:	111	228	33
1 :00 - 1 :	119	200	31
20:00 - 20:	114	139	2 3
21:00 - 21:	148	101	24
22:00 - 22:	115	72	18
23:00 - 23:	75	57	132
<b>Totals</b>	<b>188</b>	<b>26 0</b>	<b>4 3</b>
<b>AM Peak Time</b>	<b>10: - 11: 4</b>	<b>10:22 - 11:21</b>	<b>10: 4 - 11: 3</b>
<b>AM Peak olume</b>	<b>11</b>	<b>212</b>	<b>31</b>
<b>PM Peak Time</b>	<b>20:3 - 21:36</b>	<b>1 :44 - 18:43</b>	<b>1 :41 - 18:40</b>
<b>PM Peak olume</b>	<b>160</b>	<b>2 1</b>	<b>366</b>

## Daily Vehicle Volume Report

Study Date: Thursday, 07/12/2018

Unit ID:

Location: Heber Ave

	Eastbound olume	estbound olume	Total olume
00:00 - 00:	5	7	12
01:00 - 01:	7	8	1
02:00 - 02:	2	2	4
03:00 - 03:	0	1	1
04:00 - 04:	1	0	1
0 :00 - 0 :	5	4	
06:00 - 06:	18	9	2
0 :00 - 0 :	37	25	62
08:00 - 08:	62	61	123
0 :00 - 0 :	79	61	140
10:00 - 10:	85	35	120
11:00 - 11:	92	43	13
12:00 - 12:	118	83	201
13:00 - 13:	96	106	202
14:00 - 14:	95	95	1 0
1 :00 - 1 :	101	98	1
16:00 - 16:	85	95	180
1 :00 - 1 :	102	99	201
18:00 - 18:	106	67	1 3
1 :00 - 1 :	102	77	1
20:00 - 20:	71	74	14
21:00 - 21:	48	73	121
22:00 - 22:	39	57	6
23:00 - 23:	22	31	3
<b>Totals</b>	<b>13 8</b>	<b>1211</b>	<b>2 8</b>
<b>AM Peak Time</b>	<b>10:34 - 11:33</b>	<b>08:23 - 0 :22</b>	<b>10:3 - 11:38</b>
<b>AM Peak olume</b>	<b>106</b>	<b>6</b>	<b>14</b>
<b>PM Peak Time</b>	<b>12:06 - 13:0</b>	<b>16:24 - 1 :23</b>	<b>12:13 - 13:12</b>
<b>PM Peak olume</b>	<b>124</b>	<b>116</b>	<b>222</b>

## Daily Vehicle Volume Report

Study Date: Friday, 07/13/2018

Unit ID:

Location: Heber Ave

	Eastbound olume	estbound olume	Total olume
00:00 - 00:	7	6	13
01:00 - 01:	4	9	13
02:00 - 02:	3	1	4
03:00 - 03:	1	5	6
04:00 - 04:	1	0	1
0 :00 - 0 :	5	3	8
06:00 - 06:	15	10	2
0 :00 - 0 :	42	29	1
08:00 - 08:	64	62	126
0 :00 - 0 :	80	72	1 2
10:00 - 10:	88	83	1 1
11:00 - 11:	140	104	244
12:00 - 12:	152	110	262
13:00 - 13:	132	116	248
14:00 - 14:	107	125	232
1 :00 - 1 :	98	116	214
16:00 - 16:	109	88	1
1 :00 - 1 :	114	97	211
18:00 - 18:	108	75	183
1 :00 - 1 :	96	76	1 2
20:00 - 20:	83	83	166
21:00 - 21:	87	88	1
22:00 - 22:	61	86	14
23:00 - 23:	37	47	84
<b>Totals</b>	<b>1634</b>	<b>14 1</b>	<b>312</b>
<b>AM Peak Time</b>	<b>10: - 11: 6</b>	<b>10: - 11: 4</b>	<b>10: - 11: 4</b>
<b>AM Peak olume</b>	<b>143</b>	<b>10</b>	<b>24</b>
<b>PM Peak Time</b>	<b>12:00 - 12:</b>	<b>13: 3 - 14: 2</b>	<b>12:23 - 13:22</b>
<b>PM Peak olume</b>	<b>1 2</b>	<b>133</b>	<b>26</b>

## Daily Vehicle Volume Report

Study Date: Saturday, 07/14/2018

Unit ID:

Location: Heber Ave

	Eastbound olume	estbound olume	Total olume
00:00 - 00:	29	24	3
01:00 - 01:	36	25	61
02:00 - 02:	3	10	13
03:00 - 03:	2	2	4
04:00 - 04:	0	3	3
0 :00 - 0 :	1	2	3
06:00 - 06:	10	6	16
0 :00 - 0 :	31	18	4
08:00 - 08:	44	38	82
0 :00 - 0 :	51	40	1
10:00 - 10:	98	55	1 3
11:00 - 11:	123	85	208
12:00 - 12:	112	93	20
13:00 - 13:	107	89	1 6
14:00 - 14:	119	119	238
1 :00 - 1 :	82	103	18
16:00 - 16:	122	104	226
1 :00 - 1 :	113	106	21
18:00 - 18:	122	85	20
1 :00 - 1 :	109	91	200
20:00 - 20:	78	80	1 8
21:00 - 21:	64	103	16
22:00 - 22:	54	78	132
23:00 - 23:	57	42	
<b>Totals</b>	<b>1 6</b>	<b>1401</b>	<b>2 68</b>
<b>AM Peak Time</b>	<b>10: - 11: 8</b>	<b>10: 3 - 11: 2</b>	<b>10: 2 - 11: 1</b>
<b>AM Peak olume</b>	<b>124</b>	<b>8</b>	<b>211</b>
<b>PM Peak Time</b>	<b>1 :43 - 18:42</b>	<b>14:24 - 1 :23</b>	<b>14:0 - 1 :06</b>
<b>PM Peak olume</b>	<b>13</b>	<b>12</b>	<b>2 0</b>

## Daily Vehicle Volume Report

Study Date: Thursday, 07/12/2018

Unit ID:

Location: Main Street

	Northbound olume	Southbound olume	Total olume
00:00 - 00:	20	11	31
01:00 - 01:	9	12	21
02:00 - 02:	2	2	4
03:00 - 03:	1	1	2
04:00 - 04:	0	1	1
0 :00 - 0 :	1	3	4
06:00 - 06:	15	7	22
0 :00 - 0 :	26	14	40
08:00 - 08:	48	35	83
0 :00 - 0 :	49	29	8
10:00 - 10:	117	33	1 0
11:00 - 11:	163	71	234
12:00 - 12:	108	87	1
13:00 - 13:	87	59	146
14:00 - 14:	107	58	16
1 :00 - 1 :	87	49	136
16:00 - 16:	95	46	141
1 :00 - 1 :	89	54	143
18:00 - 18:	76	71	14
1 :00 - 1 :	80	91	1 1
20:00 - 20:	79	66	14
21:00 - 21:	58	60	118
22:00 - 22:	54	30	84
23:00 - 23:	39	22	61
<b>Totals</b>	<b>1410</b>	<b>12</b>	<b>2322</b>
AM Peak Time	10: 1 - 11: 0	10: - 11: 8	10: - 11: 8
AM Peak olume	1 2	2	23
PM Peak Time	14:22 - 1 :21	1 :03 - 20:02	12:00 - 12:
PM Peak olume	114		1

## Daily Vehicle Volume Report

Study Date: Friday, 07/13/2018

Unit ID:

Location: Main Street

	Northbound olume	Southbound olume	Total olume
00:00 - 00:	31	17	48
01:00 - 01:	23	15	38
02:00 - 02:	0	2	2
03:00 - 03:	0	1	1
04:00 - 04:	2	2	4
0 :00 - 0 :	2	2	4
06:00 - 06:	9	2	11
0 :00 - 0 :	23	17	40
08:00 - 08:	18	10	28
0 :00 - 0 :	50	17	6
10:00 - 10:	63	34	
11:00 - 11:	96	57	1 3
12:00 - 12:	130	68	1 8
13:00 - 13:	119	67	186
14:00 - 14:	102	74	1 6
1 :00 - 1 :	94	61	1
16:00 - 16:	112	70	182
1 :00 - 1 :	89	70	1
18:00 - 18:	74	96	1 0
1 :00 - 1 :	77	77	1 4
20:00 - 20:	86	67	1 3
21:00 - 21:	76	55	131
22:00 - 22:	93	53	146
23:00 - 23:	59	40	
<b>Totals</b>	<b>1428</b>	<b>4</b>	<b>2402</b>
AM Peak Time	10:46 - 11:4	10: 8 - 11:	10: 8 - 11:
AM Peak olume	8		1
PM Peak Time	12:0 - 13:04	18:0 - 1 :04	12:0 - 13:04
PM Peak olume	13	103	20

## Daily Vehicle Volume Report

Study Date: Saturday, 07/14/2018

Unit ID:

Location: Main Street

	Northbound olume	Southbound olume	Total olume
00:00 - 00:	35	43	8
01:00 - 01:	47	37	84
02:00 - 02:	10	1	11
03:00 - 03:	0	0	0
04:00 - 04:	1	2	3
0 :00 - 0 :	2	1	3
06:00 - 06:	6	5	11
0 :00 - 0 :	15	9	24
08:00 - 08:	26	13	3
0 :00 - 0 :	31	31	62
10:00 - 10:	55	56	111
11:00 - 11:	82	81	163
12:00 - 12:	79	65	144
13:00 - 13:	83	62	14
14:00 - 14:	46	73	11
1 :00 - 1 :	45	63	108
16:00 - 16:	69	69	138
1 :00 - 1 :	66	67	133
18:00 - 18:	50	80	130
1 :00 - 1 :	48	82	130
20:00 - 20:	47	65	112
21:00 - 21:	58	53	111
22:00 - 22:	56	46	102
23:00 - 23:	50	42	2
<b>Totals</b>	<b>100</b>	<b>1046</b>	<b>20 3</b>
<b>AM Peak Time</b>	<b>10: - 11: 6</b>	<b>10: 8 - 11:</b>	<b>10: - 11: 6</b>
<b>AM Peak olume</b>	<b>8</b>	<b>8</b>	<b>168</b>
<b>PM Peak Time</b>	<b>13:16 - 14:1</b>	<b>18:24 - 1 :23</b>	<b>18:24 - 1 :23</b>
<b>PM Peak olume</b>	<b>86</b>	<b>102</b>	<b>1 2</b>

## Daily Vehicle Volume Report

Study Date: Thursday, 07/12/2018

Unit ID:

Location: Park Ave

	Northbound olume	Southbound olume	Total olume
00:00 - 00:	13	6	1
01:00 - 01:	12	7	1
02:00 - 02:	2	1	3
03:00 - 03:	2	0	2
04:00 - 04:	1	0	1
0 :00 - 0 :	4	8	12
06:00 - 06:	9	26	3
0 :00 - 0 :	40	54	4
08:00 - 08:	74	81	1
0 :00 - 0 :	71	99	1 0
10:00 - 10:	49	118	16
11:00 - 11:	57	122	1
12:00 - 12:	92	153	24
13:00 - 13:	122	118	240
14:00 - 14:	113	123	236
1 :00 - 1 :	119	131	2 0
16:00 - 16:	129	115	244
1 :00 - 1 :	123	125	248
18:00 - 18:	99	125	224
1 :00 - 1 :	93	129	222
20:00 - 20:	86	80	166
21:00 - 21:	94	53	14
22:00 - 22:	67	41	108
23:00 - 23:	39	27	66
<b>Totals</b>	<b>1 10</b>	<b>1 42</b>	<b>32 2</b>
<b>AM Peak Time</b> 0 : 6 - 08:	<b>10:33 - 11:32</b>	<b>10:3 - 11:38</b>	
<b>AM Peak olume</b>	<b>8</b>	<b>13</b>	<b>1 4</b>
<b>PM Peak Time</b> 16:26 - 1 :2	<b>12:0 - 13:04</b>	<b>12:13 - 13:12</b>	
<b>PM Peak olume</b>	<b>1 1</b>	<b>160</b>	<b>26</b>

## Daily Vehicle Volume Report

Study Date: Friday, 07/13/2018

Unit ID:

Location: Park Ave

	Northbound olume	Southbound olume	Total olume
00:00 - 00:	10	9	1
01:00 - 01:	12	4	16
02:00 - 02:	1	5	6
03:00 - 03:	5	2	
04:00 - 04:	0	2	2
0 :00 - 0 :	8	6	14
06:00 - 06:	11	19	30
0 :00 - 0 :	34	52	86
08:00 - 08:	90	75	16
0 :00 - 0 :	106	110	216
10:00 - 10:	118	116	234
11:00 - 11:	122	171	2 3
12:00 - 12:	140	184	324
13:00 - 13:	157	163	320
14:00 - 14:	156	128	284
1 :00 - 1 :	142	125	26
16:00 - 16:	125	136	261
1 :00 - 1 :	118	148	266
18:00 - 18:	104	139	243
1 :00 - 1 :	105	121	226
20:00 - 20:	95	100	1
21:00 - 21:	89	88	1
22:00 - 22:	98	75	1 3
23:00 - 23:	54	41	
<b>Totals</b>	<b>1 00</b>	<b>201</b>	<b>3 1</b>
<b>AM Peak Time</b>	<b>10:30 - 11:2</b>	<b>10: 6 - 11:</b>	<b>10: - 11: 4</b>
<b>AM Peak olume</b>	<b>13</b>	<b>1 3</b>	<b>2</b>
<b>PM Peak Time</b>	<b>13: 1 - 14: 0</b>	<b>12:00 - 12:</b>	<b>12:22 - 13:21</b>
<b>PM Peak olume</b>	<b>1 2</b>	<b>184</b>	<b>333</b>

## Daily Vehicle Volume Report

Study Date: Saturday, 07/14/2018

Unit ID:

Location: Park Ave

	Northbound olume	Southbound olume	Total olume
00:00 - 00:	33	38	1
01:00 - 01:	29	31	60
02:00 - 02:	12	3	1
03:00 - 03:	2	2	4
04:00 - 04:	2	0	2
0 :00 - 0 :	4	3	
06:00 - 06:	7	15	22
0 :00 - 0 :	25	42	6
08:00 - 08:	45	62	10
0 :00 - 0 :	50	66	116
10:00 - 10:	74	121	1
11:00 - 11:	96	142	238
12:00 - 12:	96	153	24
13:00 - 13:	112	127	23
14:00 - 14:	117	144	261
1 :00 - 1 :	130	109	23
16:00 - 16:	130	160	2 0
1 :00 - 1 :	105	133	238
18:00 - 18:	92	153	24
1 :00 - 1 :	101	142	243
20:00 - 20:	79	94	1 3
21:00 - 21:	95	76	1 1
22:00 - 22:	85	62	14
23:00 - 23:	50	60	110
<b>Totals</b>	<b>1 1</b>	<b>1 38</b>	<b>3 0</b>
<b>AM Peak Time</b>	<b>10: 3 - 11: 2</b>	<b>11:00 - 11:</b>	<b>10: - 11: 8</b>
<b>AM Peak olume</b>		<b>142</b>	<b>23</b>
<b>PM Peak Time</b>	<b>1 :31 - 16:30</b>	<b>1 :24 - 18:23</b>	<b>1 : - 16: 8</b>
<b>PM Peak olume</b>	<b>143</b>	<b>168</b>	<b>2 3</b>