

Copyright Reserved

The Contractor shall verify and be responsible for all dimensions. DO NOT scale the drawing - any errors or omissions shall be reported to Stantec without delay.  
The Copyrights to all designs and drawings are the property of Stantec. Reproduction or use for any purpose other than that authorized by Stantec is forbidden.

Owner/Project

- NATURAL DRAINAGE CHANNEL
- EXISTING WATERLINE
- NEW WATERLINE
- EXISTING SANITARY SEWER
- NEW SANITARY SEWER
- NEW STORM DRAIN

Legend

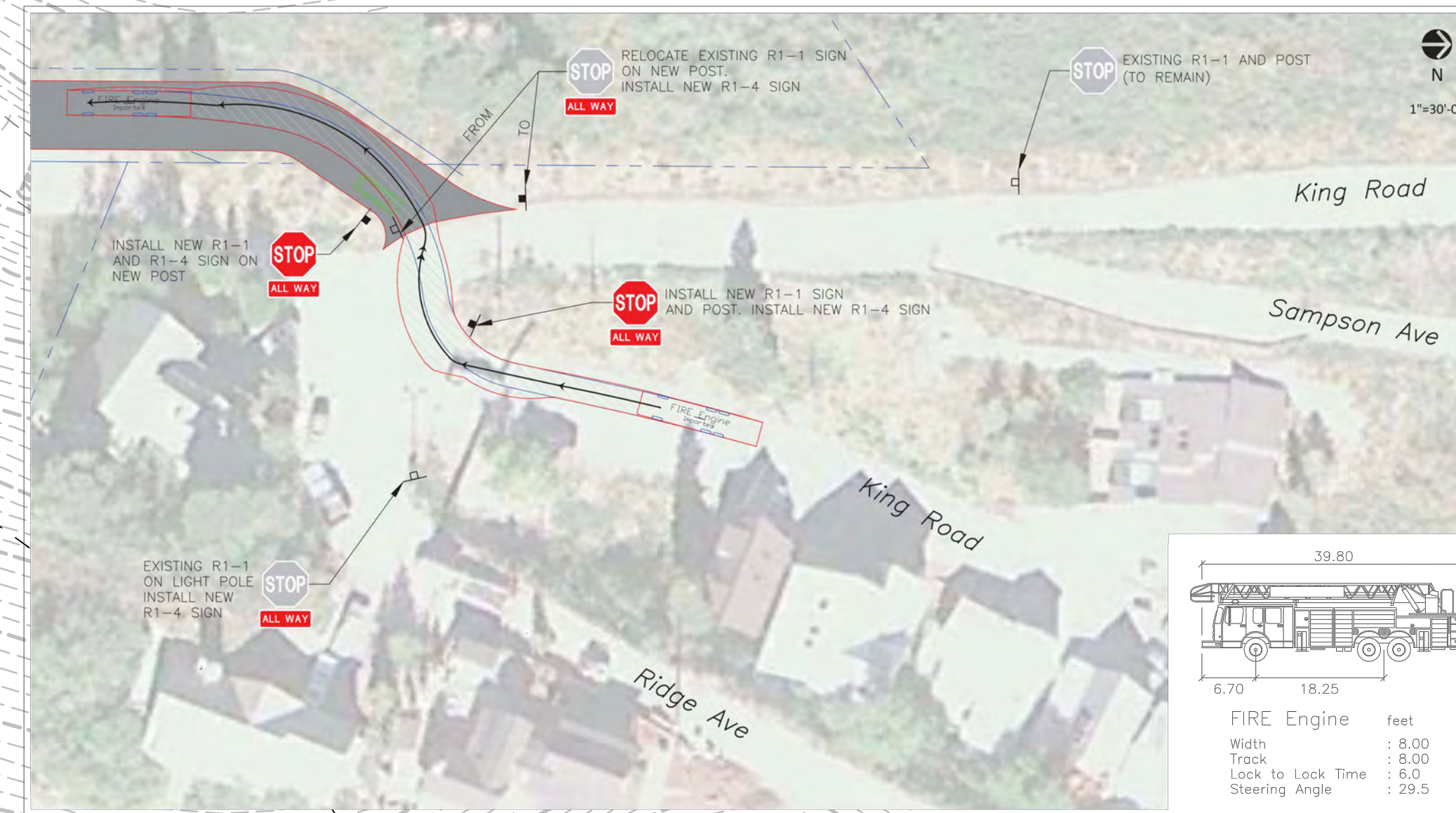

FEHR PEERS  
Proposed Sight Distance Conditions - All-Way Stop - Emergency Vehicle Turning Movement

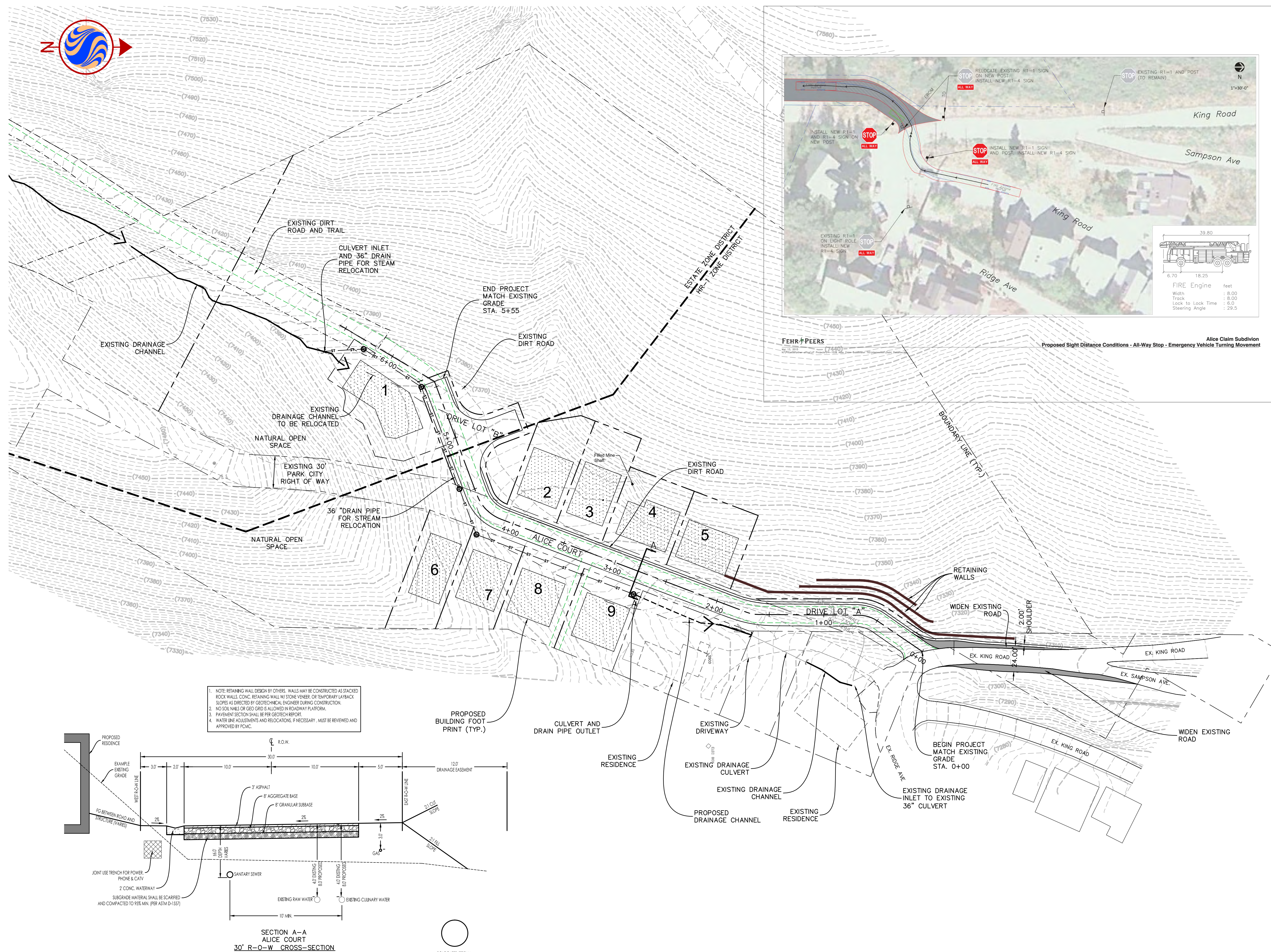

1. NOTE: RETAINING WALL DESIGN BY OTHERS. WALLS MAY BE CONSTRUCTED AS STACKED ROCK WALLS, CONC. RETAINING WALL W/ STONE VENEER, OR TEMPORARY LABACK SLOPES AS DIRECTED BY GEOTECHNICAL ENGINEER DURING CONSTRUCTION.
2. NO SOIL NAILS OR GEO GRID IS ALLOWED IN ROADWAY PLATFORM.
3. PAVEMENT SECTION SHALL BE PER GEOTECH REPORT.
4. WATERLINE ADJUSTMENTS AND RELOCATIONS, IF NECESSARY, MUST BE REVIEWED AND APPROVED BY PCMC.

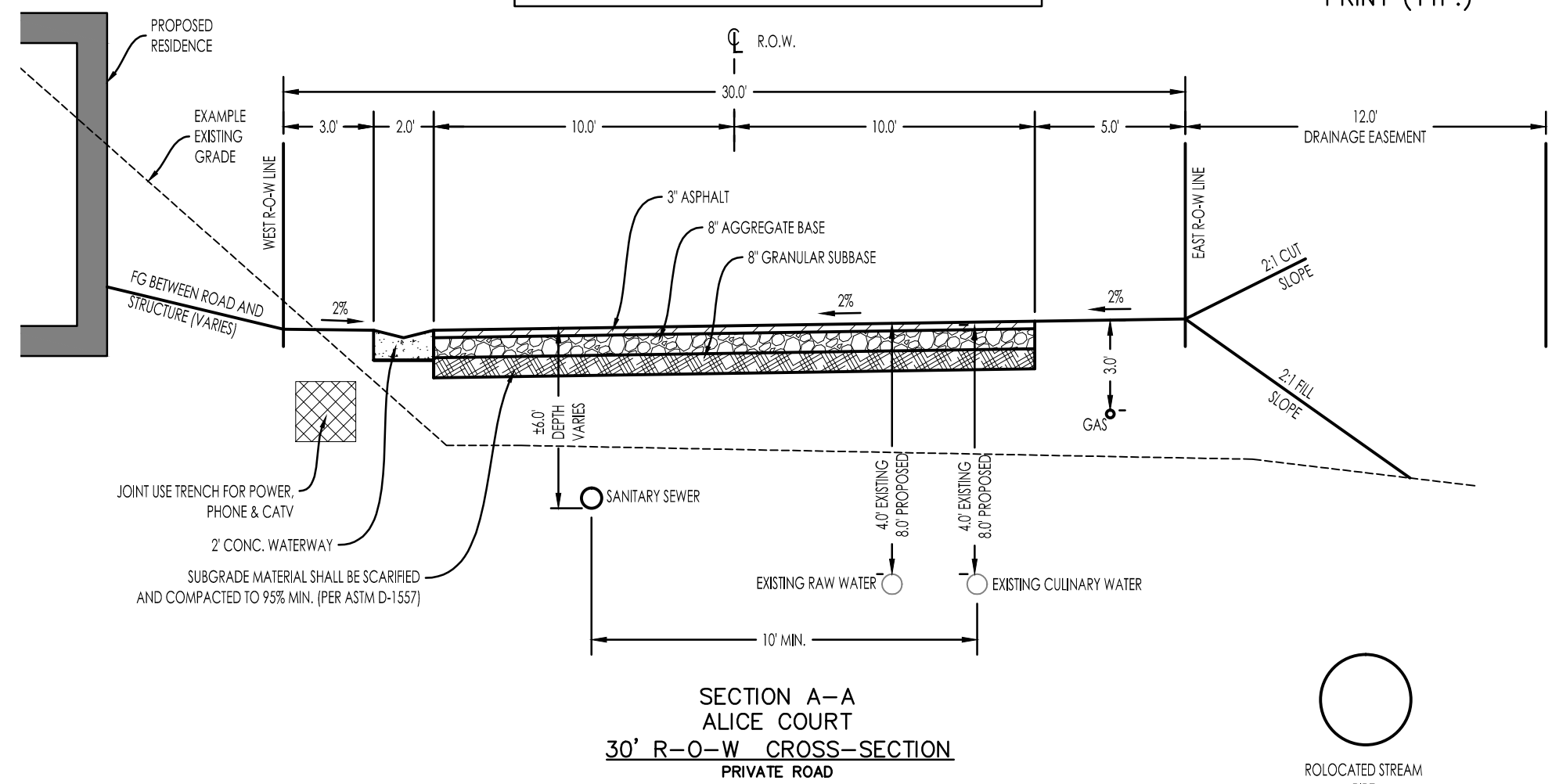

| Revision | By | Appd. | YY.MM.DD |
|----------|----|-------|----------|
| 4        | CB | SB    | 14.04.20 |
| 3        | CB | PMD   | 15.03.27 |
| 2        | CB | PMD   | 15.03.16 |
| 1        | CB | JRJ   | 15.01.23 |

|            |               |      |       |       |          |
|------------|---------------|------|-------|-------|----------|
| File Name: | C:\100.sp.dwg | SDJ  | JRJ   | EKW   | 14.12.19 |
|            |               | Dwn. | Chkd. | Dsgn. | YY.MM.DD |

Client/Project  
**KING DEVELOPMENT L.L.C.**  
 PO BOX 244  
 PARK CITY, UTAH 84060  
 ALICE CLAIM  
 Park City, Utah

Title  
**SITE PLAN**

|             |           |          |        |
|-------------|-----------|----------|--------|
| Project No. | 205303057 | Scale    | 1"=40' |
| Drawing No. | C100      | Sheet    | of     |
|             |           | Revision | 0      |







Copyright Reserved

The Contractor shall verify and be responsible for all dimensions. DO NOT scale the drawing - any errors or omissions shall be reported to Stantec without delay.  
The Copyrights to all designs and drawings are the property of Stantec. Reproduction or use for any purpose other than that authorized by Stantec is forbidden.

Owner/Project

- LOD LIMITS OF DISTURBANCE
- SF SILT FENCE (ALT. STRAW WATTLE)
- TEMPORARY RETAINING WALL
- PROPERTY/LOT LINE
- EXISTING CONTOUR LINE
- FINISH CONTOUR LINE
- # CLEAN UP AREA DESIGNATION

1. TEMPORARY RETAINING WALLS SHALL BE CONSTRUCTED ACROSS FUTURE DRIVEWAYS. FUTURE DRIVEWAYS AND FUTURE RETAINING WALLS N.I.C.
2. ALL UTILITY WORK IS FUTURE AND SUBJECT TO REVIEW AND REVISION.

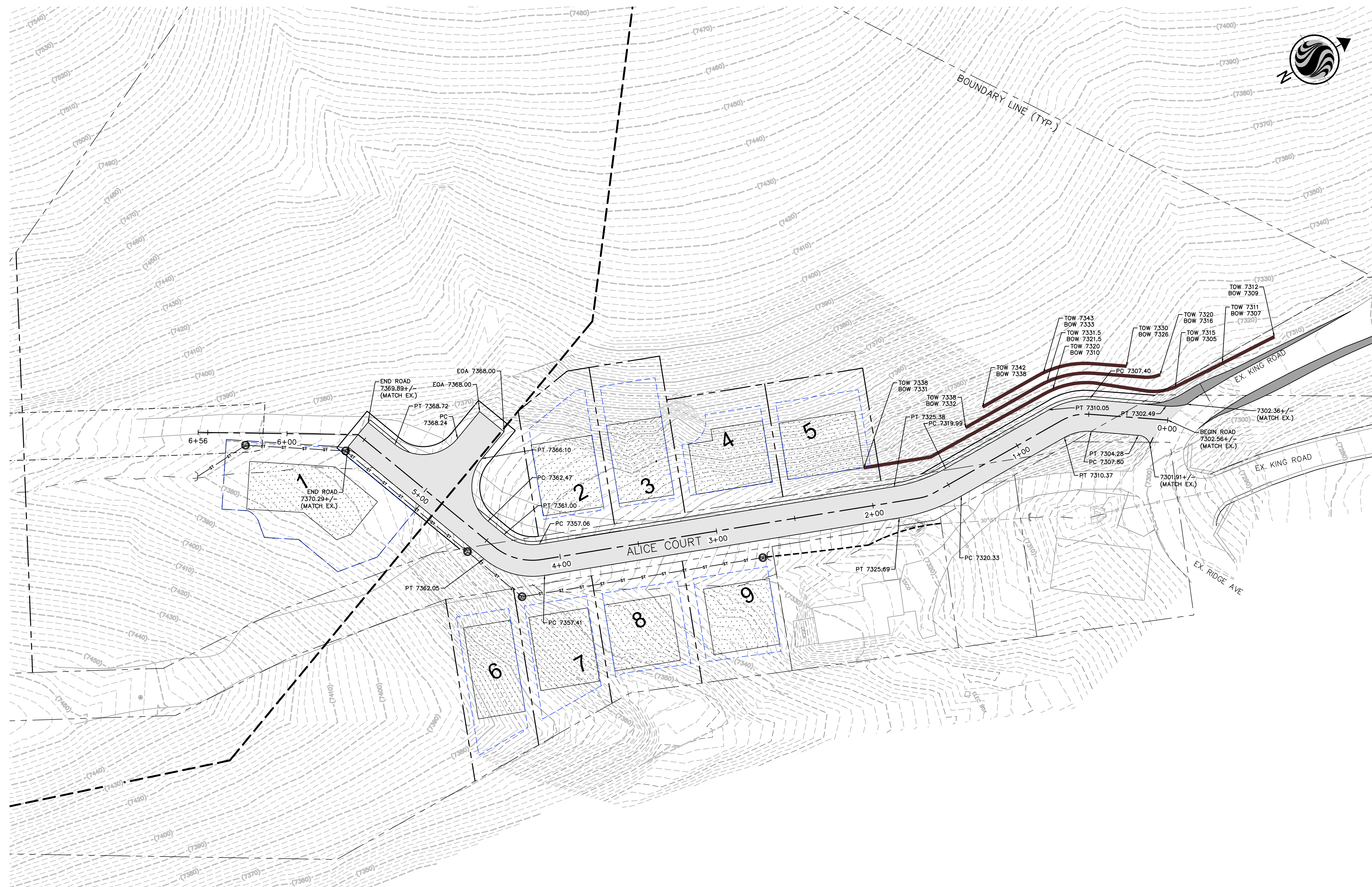

| Revision | By | Appd. | YY.MM.DD |
|----------|----|-------|----------|
|          |    |       |          |
|          |    |       |          |
|          |    |       |          |
|          |    |       |          |

|   |                        |    |     |          |
|---|------------------------|----|-----|----------|
| 4 | NEW DRAINAGE CALCS     | CB | SB  | 14.04.20 |
| 3 | PARK CITY RE-SUBMITTAL | BD | PMD | 15.03.27 |
| 2 | PARK CITY RE-SUBMITTAL | CB | PMD | 15.03.16 |
| 1 | PARK CITY SUBMITTAL    | CB | JRJ | 15.01.23 |

| Issued | By | Appd. | YY.MM.DD |
|--------|----|-------|----------|
|        |    |       |          |

| File Name:   | SDJ  | JRJ   | EKW   | 14.12.19 |
|--------------|------|-------|-------|----------|
| c-300 gp.dwg | Dwn. | Chkd. | Dsgn. | YY.MM.DD |

Permit-Seal



Client/Project

KING DEVELOPMENT L.L.C.  
PO BOX 244  
PARK CITY, UTAH 84060

ALICE CLAIM  
Park City, Utah

Title

GRADING PLAN

| Project No. | Scale  |
|-------------|--------|
| 205303057   | 1"=40' |

| Drawing No. | Sheet | Revision |
|-------------|-------|----------|
| C300        | of    | 0        |

C300 of 0



Copyright Reserved

The Contractor shall verify and be responsible for all dimensions. DO NOT scale the drawing - any errors or omissions shall be reported to Stantec without delay.  
The Copyrights to all designs and drawings are the property of Stantec. Reproduction or use for any purpose other than that authorized by Stantec is forbidden.

Owner/Project

Legend

NOTES:

- MODIFICATIONS TO EXISTING DRAINING CHANNEL WILL REQUIRE STATE STREAM ALTERATION PERMIT.

| Revision | By                     | Appd. | YY.MM.DD       |
|----------|------------------------|-------|----------------|
| 4        | NEW DRAINAGE CALCS     | CB    | SB 14.04.20    |
| 3        | PARK CITY RE-SUBMITTAL | BD    | PMD 15.03.27   |
| 2        | PARK CITY RE-SUBMITTAL | CB    | PMD 15.03.16   |
| 1        | PARK CITY SUBMITTAL    | CB    | JRJ 15.01.23   |
| Issued   |                        | By    | Appd. YY.MM.DD |

|                        |      |       |       |          |
|------------------------|------|-------|-------|----------|
| File Name: C-301dp.dwg | SDJ  | JRJ   | EKW   | 14.12.19 |
|                        | Dwn. | Chkd. | Dsgn. | YY.MM.DD |

Permit-Seal

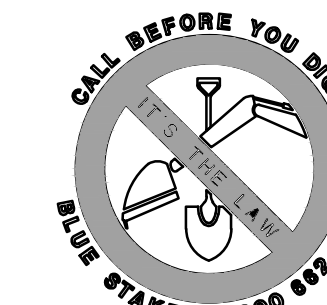
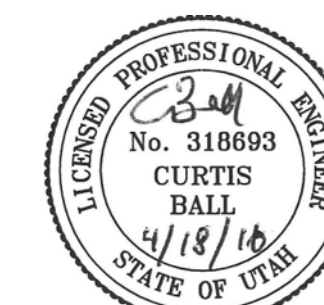

Client/Project

KING DEVELOPMENT L.L.C.  
PO BOX 244  
PARK CITY, UTAH 84060

ALICE CLAIM  
Park City, Utah

Title

DRAINAGE PLAN

|                          |                 |       |          |
|--------------------------|-----------------|-------|----------|
| Project No.<br>205303057 | Scale<br>1"=40' | Sheet | Revision |
|--------------------------|-----------------|-------|----------|

Drawing No. Sheet of Revision

C301

of

0

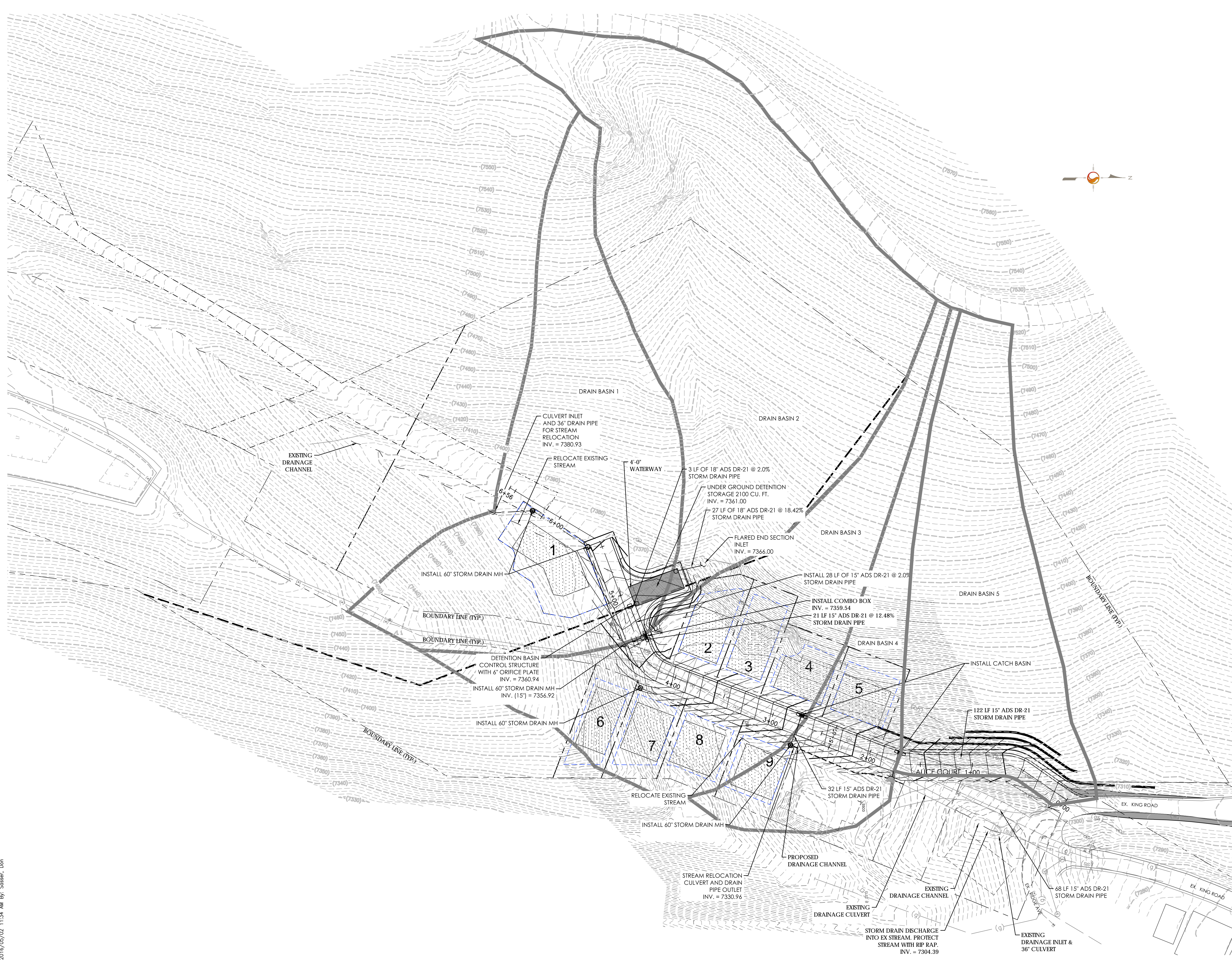

I:\2053\Active\205303057\Drawings\Sheets\C-301dp.dwg  
 20/10/25/02 11:34 AM By: Sasser, Don  
 ORIGINAL SHEET - ARCH D



Copyright Reserved

The Contractor shall verify and be responsible for all dimensions. DO NOT scale the drawing - any errors or omissions shall be reported to Stantec without delay.  
The Copyrights to all designs and drawings are the property of Stantec. Reproduction or use for any purpose other than that authorized by Stantec is forbidden.

Owner/Project

Legend

1. TEMPORARY RETAINING WALLS SHALL BE CONSTRUCTED ACROSS FUTURE DRIVEWAYS. FUTURE DRIVEWAYS AND FUTURE RETAINING WALLS N.I.C.
2. ALL UTILITY WORK IS FUTURE AND SUBJECT TO REVIEW AND REVISION.

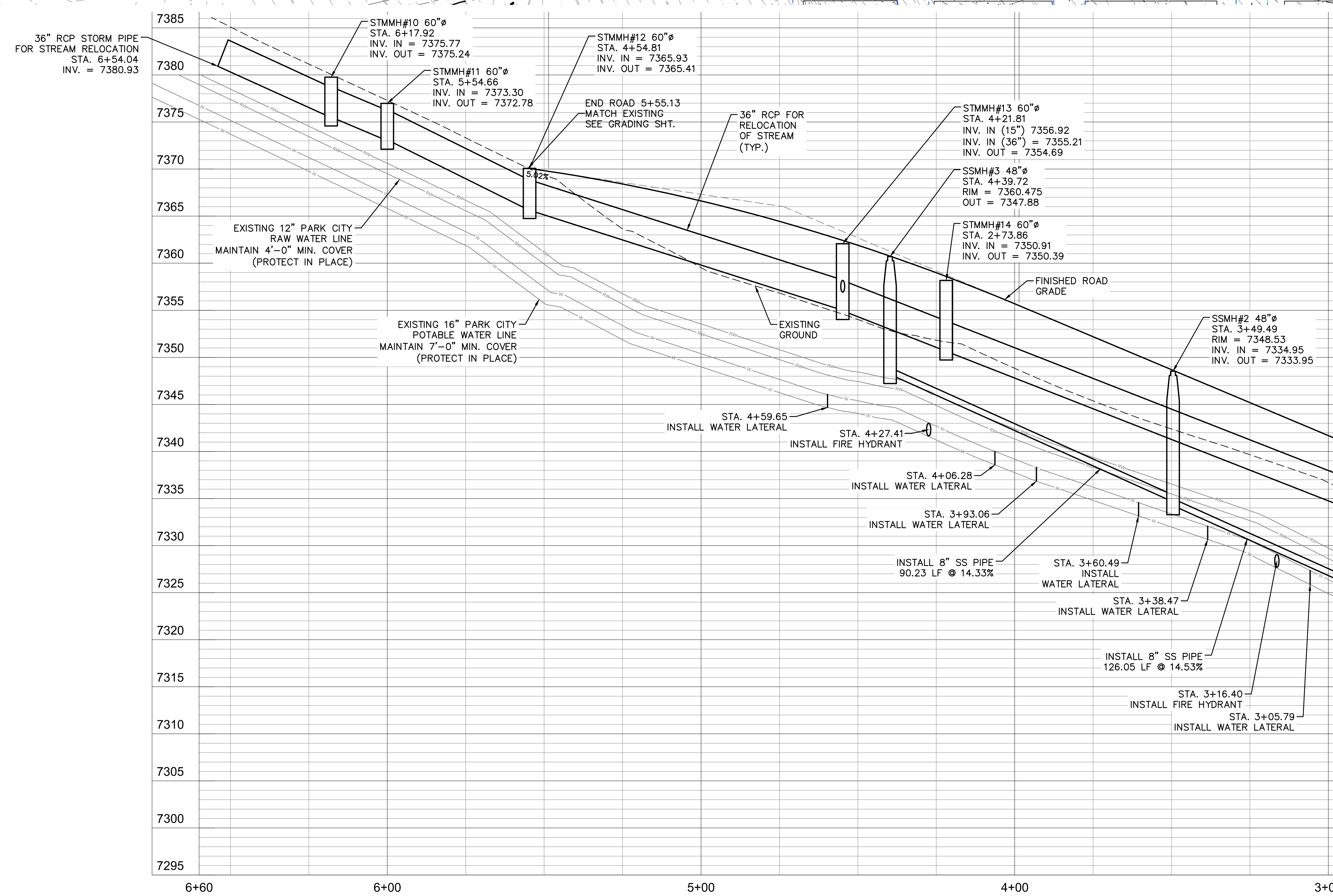
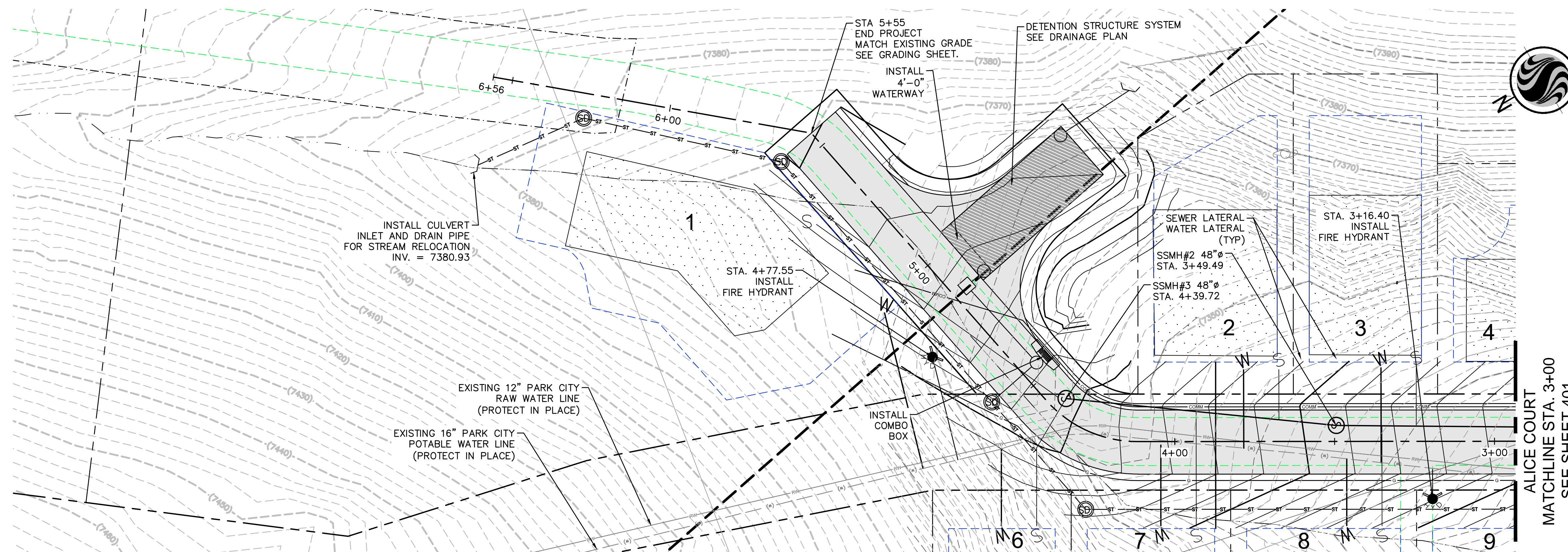

ALICE COURT  
MATCHLINE STA. 3+00  
SEE SHEET 401

|  |  |  |  |
|--|--|--|--|
|  |  |  |  |
|  |  |  |  |
|  |  |  |  |
|  |  |  |  |

| Revision | By                     | Appd. | YY.MM.DD       |
|----------|------------------------|-------|----------------|
| 3        | PARK CITY RE-SUBMITTAL | BD    | PMD 15.03.27   |
| 2        | PARK CITY RE-SUBMITTAL | CB    | PMD 15.03.16   |
| 1        | PARK CITY SUBMITTAL    | CB    | JRJ 15.01.23   |
| Issued   |                        | By    | Appd. YY.MM.DD |

|                                     |      |       |       |          |
|-------------------------------------|------|-------|-------|----------|
| File Name: C-400 PP-ALICE COURT.dwg | SDJ  | JRJ   | EKW   | 14.12.19 |
|                                     | Dwn. | Chkd. | Dsgn. | YY.MM.DD |

Permit-Seal

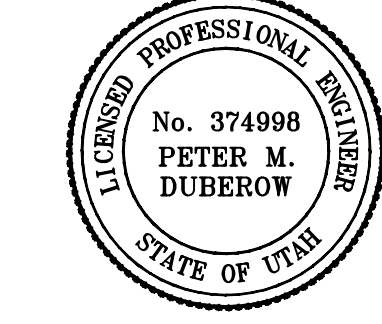

Client/Project  
**KING DEVELOPMENT L.L.C.**  
 PO BOX 244  
 PARK CITY, UTAH 84060  
  
 ALICE CLAIM  
 Park City, Utah

Title  
**ALICE GULCH  
 PLAN AND PROFILE**

|                          |                 |               |               |
|--------------------------|-----------------|---------------|---------------|
| Project No.<br>205303057 | Scale<br>1"=20' | Sheet<br>C400 | Revision<br>0 |
|--------------------------|-----------------|---------------|---------------|

Drawing No. C400 of 0





Copyright Reserved

The Contractor shall verify and be responsible for all dimensions. DO NOT scale the drawing - any errors or omissions shall be reported to Stantec without delay.  
The Copyrights to all designs and drawings are the property of Stantec. Reproduction or use for any purpose other than that authorized by Stantec is forbidden.

Owner/Project

Legend

1. TEMPORARY RETAINING WALLS SHALL BE CONSTRUCTED ACROSS FUTURE DRIVEWAYS. FUTURE DRIVEWAYS AND FUTURE RETAINING WALLS N.I.C.
2. ALL UTILITY WORK IS FUTURE AND SUBJECT TO REVIEW AND REVISION.

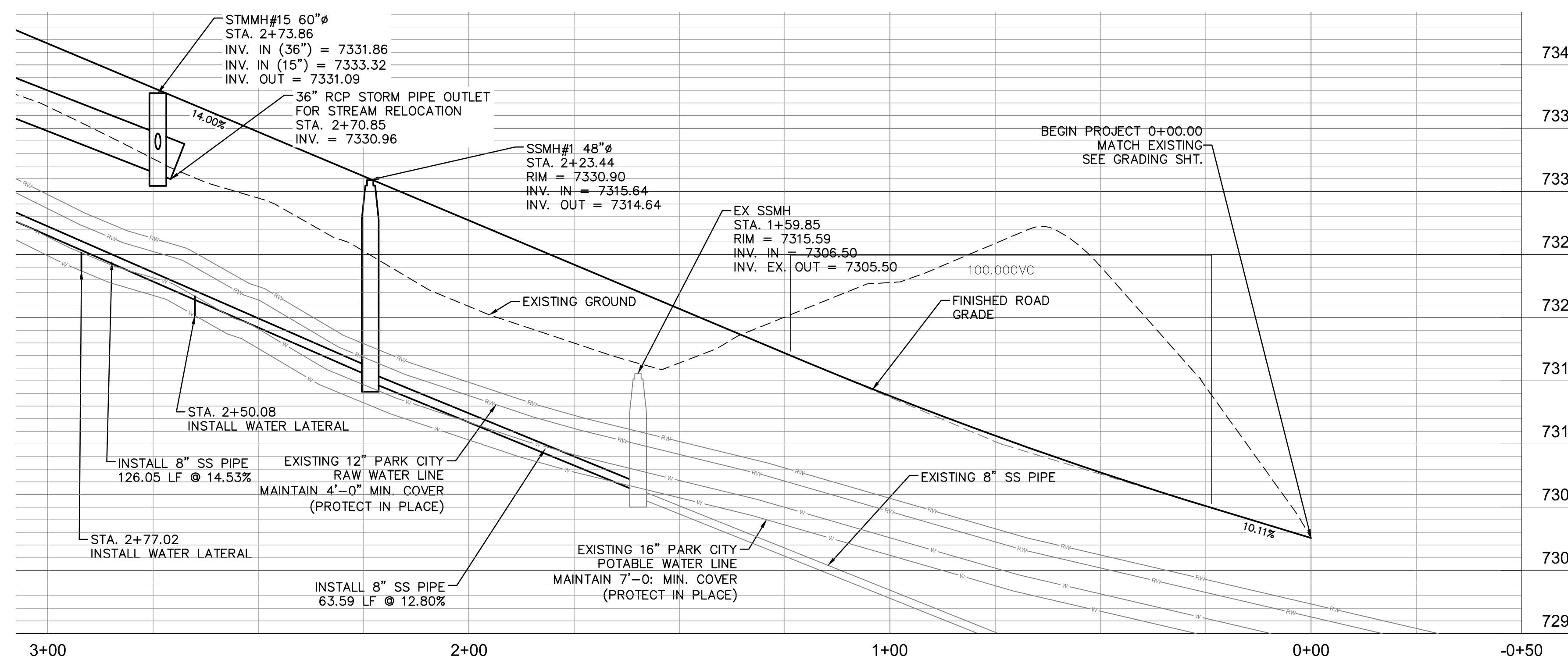
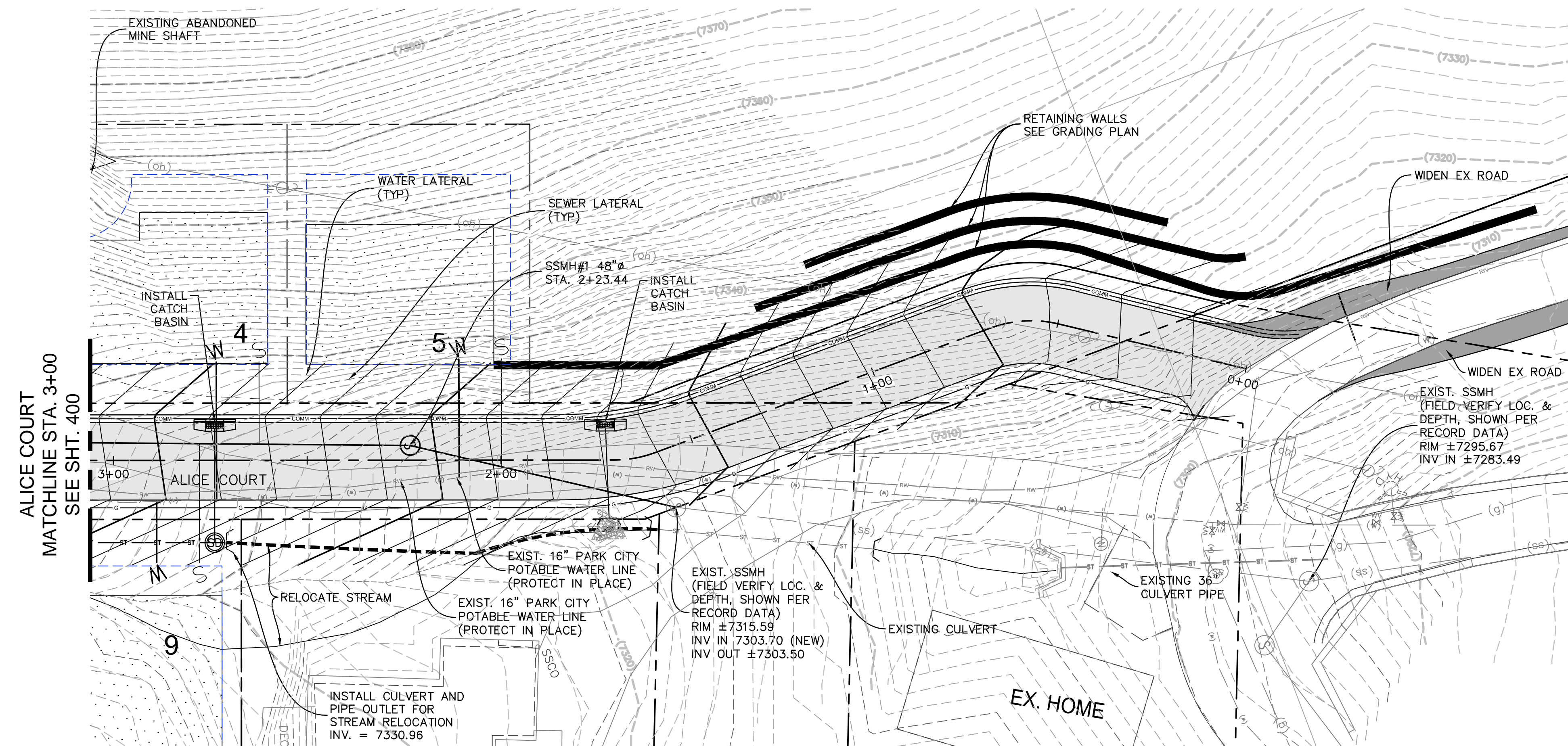

| Revision | By | Appd. | YY.MM.DD |
|----------|----|-------|----------|
|          |    |       |          |
|          |    |       |          |
|          |    |       |          |
|          |    |       |          |

|   |                        |    |     |          |
|---|------------------------|----|-----|----------|
| 3 | PARK CITY RE-SUBMITTAL | BD | PMD | 15.03.27 |
| 2 | PARK CITY RE-SUBMITTAL | CB | PMD | 15.03.16 |
| 1 | PARK CITY SUBMITTAL    | CB | JRJ | 15.01.23 |

| Issued | By | Appd. | YY.MM.DD |
|--------|----|-------|----------|
|        |    |       |          |

| File Name:                | SDJ  | JRJ   | EKW   | 14.12.19 |
|---------------------------|------|-------|-------|----------|
| C:\401 PP-ALICE COURT.dwg | Dwn. | Chkd. | Dsgn. |          |

Permit-Seal



Client/Project  
**KING DEVELOPMENT L.L.C.**  
 PO BOX 244  
 PARK CITY, UTAH 84060

Alice CLAIM  
 Park City, Utah

Title  
**ALICE GULCH  
 PLAN AND PROFILE**

Project No. 205303057  
 Scale 1"=20'

Drawing No. Sheet of Revision

**C401** of 0



**EROSION CONTROL NOTES:**

1. CONTROLLING SEDIMENT TRANSPORT AND PREVENTING AND/OR CORRECTING PROBLEMS ASSOCIATED WITH EROSION AND RUNOFF PROCESSES THAT COULD OCCUR BOTH DURING AND AFTER PROJECT CONSTRUCTION WILL BE CLOSELY MONITORED. PERIODIC MAINTENANCE AND INSPECTION OF SEDIMENT CONTROL DEVICES WILL BE SCHEDULED. PARTICULAR ATTENTION SHALL BE GIVEN TO EXISTING DRAINAGE PATTERNS THAT RUN THROUGH DISTURBED AREAS AND OVER EXTREME SLOPES. THESE PATTERNS WILL BE IDENTIFIED TO ISOLATE PROBLEM AREAS WHERE WATER WILL CONCENTRATE. PROVISIONS SHALL BE MADE TO CHANNEL RUNOFF AWAY FROM NEW OR EXISTING IMPROVEMENTS TO PREVENT UNDERMINING AND GENERAL SITE EROSION. THESE PROVISIONS SHALL BE STABILIZED AND SHALL REMAIN IN PLACE UNTIL THE PERMANENT STORM DRAINAGE FACILITIES ARE INSTALLED AND FUNCTIONAL.
2. EROSION CONTROL - A STORMWATER POLLUTION PREVENTION PLAN (SWPPP) WILL BE PROVIDED BY OTHERS IN ACCORDANCE WITH THE UTAH POLLUTANT DISCHARGE ELIMINATION SYSTEM (UPDES) PERMIT FOR CONSTRUCTION, OUTLINING HOW EROSION AND SILTATION WILL BE CONTROLLED. A NOTICE OF INTENT (NOI) WILL BE SUBMITTED BY OTHERS TO OBTAIN THE UPDES CONSTRUCTION PERMIT. A COPY OF THE PLAN MUST BE ON SITE AT ALL TIMES. THE CONTRACTOR SHALL BE RESPONSIBLE FOR IMPLEMENTING THE PLAN AND INSTALLING AND MAINTAINING THE EROSION CONTROL FACILITIES WITH EACH PHASE OF WORK. SHOULD SILT LEAVE THE SITE OR EROSION OCCURS, IT WILL BE THE CONTRACTOR'S RESPONSIBILITY TO TAKE CORRECTIVE ACTION AND REPAIR ANY DAMAGE CAUSED BY THE SILT OR EROSION IMMEDIATELY. ALL COSTS ASSOCIATED WITH THE MODIFICATION AND APPROVAL OF THE PLAN WILL BE THE RESPONSIBILITY OF THE CONTRACTOR.
3. BEFORE CONSTRUCTION BEGINS, THE LIMITS OF DISTURBANCE (LOD) BOUNDARY SHALL BE FLAGGED ON SITE AND APPROVED BY THE ENGINEER. UNDER NO CIRCUMSTANCES SHALL SITE DISTURBANCE OCCUR OUTSIDE THE DESIGNATED AREAS AT ANY TIME DURING CONSTRUCTION.
4. EXCAVATION AND EMBANKMENT OPERATIONS SHALL PROCEED IN SUCH A MANNER SO THAT FINISHING OF SLOPES, INCLUDING REVEGETATION SHALL BE ACCOMPLISHED AS SOON AS POSSIBLE AFTER ROUGH GRADING. ALL SLOPES 2:1 OR FLATTER SHALL BE SCARIFIED WITH HEAVY EQUIPMENT, LEAVING TRACKS PERPENDICULAR TO THE SLOPE.
5. CUT SLOPES SHALL BE 1:1 MAXIMUM AND FILL SLOPES 2:1 MAXIMUM UNLESS ROCK IS ENCOUNTERED OR RETAINING WALLS CONSTRUCTED. CUT SLOPES IN ROCK MAY BE STEEPENED, DEPENDING UPON GEOTECHNICAL CONSIDERATIONS. THE TOPS OF ALL CUT SLOPES IN SOIL SHALL BE ROUNDED FOR A HORIZONTAL DISTANCE OF THREE (3) FEET BEYOND THE CATCH POINT. SLOPE ROUNDING SHALL OCCUR AS THE SLOPE IS BEING BROUGHT DOWN. THE OVERALL SHAPE, HEIGHT AND GRADE OF ANY CUT AND/OR FILL SLOPE SHALL BE DEVELOPED IN CONCERT WITH THE EXISTING NATURAL CONTOURS, SCALE AND VEGETATION OF NATURAL TERRAIN.
6. STABILIZATION PRACTICES MAY INCLUDE, BUT NOT BE LIMITED TO, TEMPORARY SEEDING, PERMANENT SEEDING, MULCHING, GEOTEXTILES, SOD STABILIZATION, VEGETATIVE BUFFER STRIPS, PROTECTION OF TREES, PRESERVATION OF NATURAL VEGETATION AND OTHER APPROPRIATE MEASURES. USE OF IMPERVIOUS SURFACES FOR STABILIZATION SHALL BE AVOIDED, EXCEPT AS PROVIDED BELOW. STABILIZATION MEASURES SHALL BE INITIATED AS SOON AS POSSIBLE IN DISTURBED PORTIONS OF THE SITE WHERE CONSTRUCTION ACTIVITIES HAVE PERMANENTLY CEASED, BUT IN NO CASE MORE THAN 14 DAYS AFTER THE CONSTRUCTION ACTIVITY IN THAT PORTION OF THE SITE HAS TEMPORARILY OR PERMANENTLY CEASED.
  - A. WHERE DEEP SNOW OR FROZEN GROUND CONDITIONS PRECLUDE THE INITIATION OF STABILIZATION MEASURES BY THE 14TH DAY AFTER CONSTRUCTION ACTIVITY PERMANENTLY CEASES, STABILIZATION MEASURES SHALL BE INITIATED AS SOON AS PRACTICABLE.
  - B. WHERE CONSTRUCTION ACTIVITY ON A PORTION OF THE SITE IS TEMPORARILY CEASED, AND EARTH DISTURBING WILL RESUME WITHIN 21 WORKING DAYS, TEMPORARY STABILIZATION MEASURES NEED NOT BE INITIATED ON THAT PORTION OF THE SITE.
7. SPECIFICALLY OUTLINED DISTURBED AREAS, BOTH ON AND OFF-SITE SHALL BE REVEGETATED. THESE AREAS SHALL INCLUDE, BUT NOT BE LIMITED TO, ALL UNSURFACED AREAS WITHIN THE FLAGGED LOD, STAGING AND STORAGE AREAS, MATERIAL WASTE AREAS, UNDERGROUND UTILITY CONSTRUCTION AREAS, BENCHED AREAS, INCLUDE RETAINING WALL BENCHES, AND TEMPORARY OR EXISTING ACCESS ROADS USED FOR CONSTRUCTION ACTIVITIES. CUT AND FILL SLOPES OVER 3:1 REQUIRE THE PLACEMENT OF EROSION CONTROL/REVEGETATION MATTING. SLOPES LESS THAN 3:1 MAY BE SPRAYED WITH TACKIFIER. ROCK CUTS STEEPER THAN 1:1 WILL NOT BE REVEGETATED.
8. SEDIMENT TRAPS MUST OUTLET ONTO STABILIZED (PREFERABLY UNDISTURBED) GROUND OR LEFT TO PERCOLATE INTO THE GROUND.
9. CONTROLLED OUTLETS SHALL DIRECT COLLECTED RUNOFF THROUGH SILT FENCES OR STRAW BALES
10. TYPICAL FUGITIVE DUST SHALL BE CONTROLLED BY WATERING AND/OR CHEMICAL STABILIZATION, PROVIDING VEGETATIVE OR SYNTHETIC COVER AND WIND BREAKS ARE CONSISTENT WITH THE UTAH STATE DIVISION OF AIR QUALITY STANDARDS.
11. ANY SEDIMENT TRACKED OFF-SITE SHALL BE REMOVED PRIOR TO THE END OF THE WORK SHIFT OR PRIOR TO SUNSET, WHICHEVER COMES FIRST.
12. CONTRACTOR MAY ADJUST THE LOCATIONS OF THE CONSTRUCTION FENCE, CONSTRUCTION TRAILERS, AND CONSTRUCTION MATERIALS RECEIVING AND STORAGE AREAS, AS NEEDED TO ACCOMPLISH THE CONSTRUCTION. ALL CHANGES SHALL BE NOTATED ON THE EROSION CONTROL PLAN.
13. CONTRACTOR SHALL CONDUCT PERIODIC INSPECTIONS OF THE EROSION CONTROL MEASURES, AS REQUIRED AND NOTATED IN THE SWPPP. THE CONTRACTOR WILL MAINTAIN A LOG ON-SITE OF ALL INSPECTIONS WITH THE SWPPP.

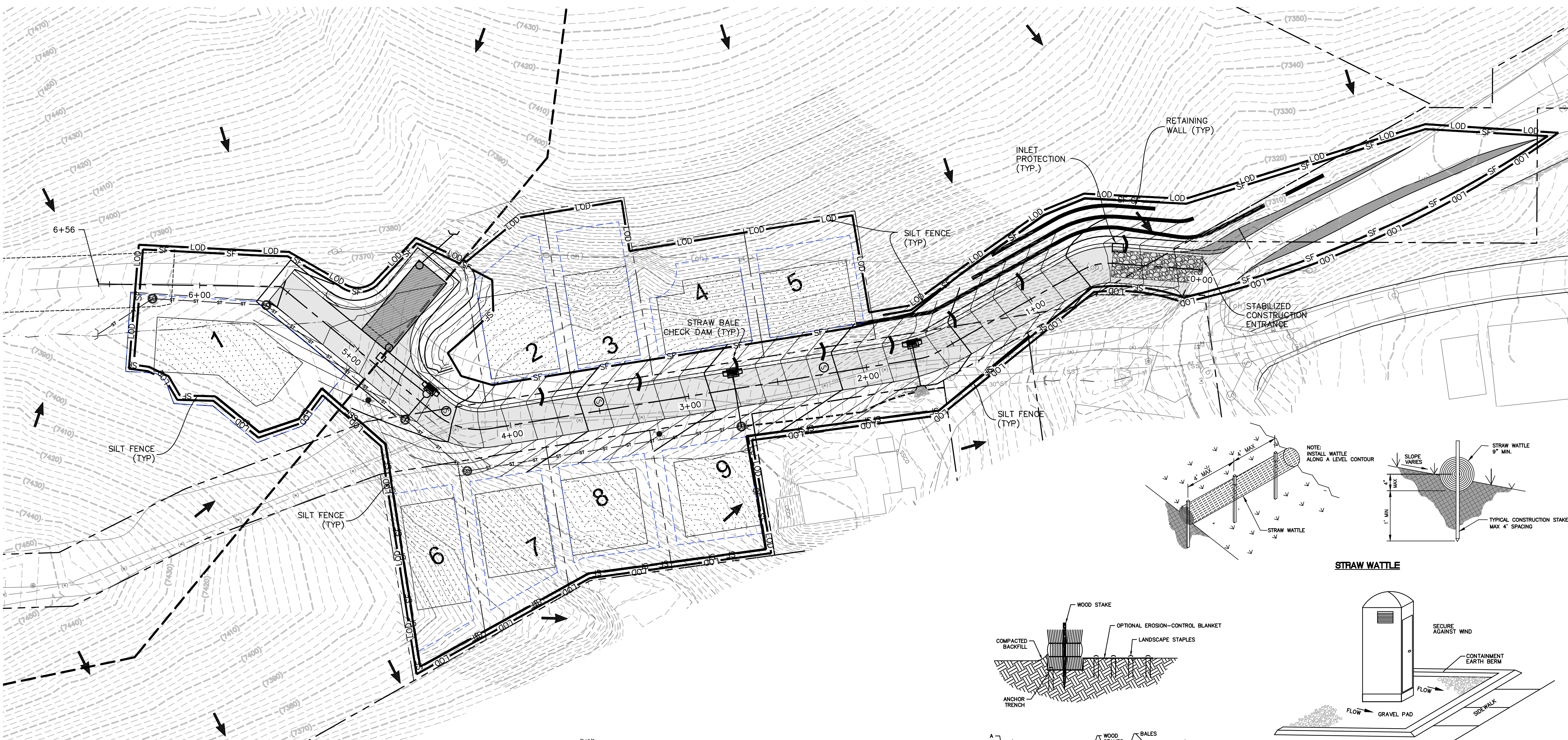

Copyright Reserved  
The Contractor shall verify and be responsible for all dimensions. DO NOT scale the drawing - any errors or omissions shall be reported to Stantec without delay.  
The Copyrights to all designs and drawings are the property of Stantec. Reproduction or use for any purpose other than that authorized by Stantec is forbidden.

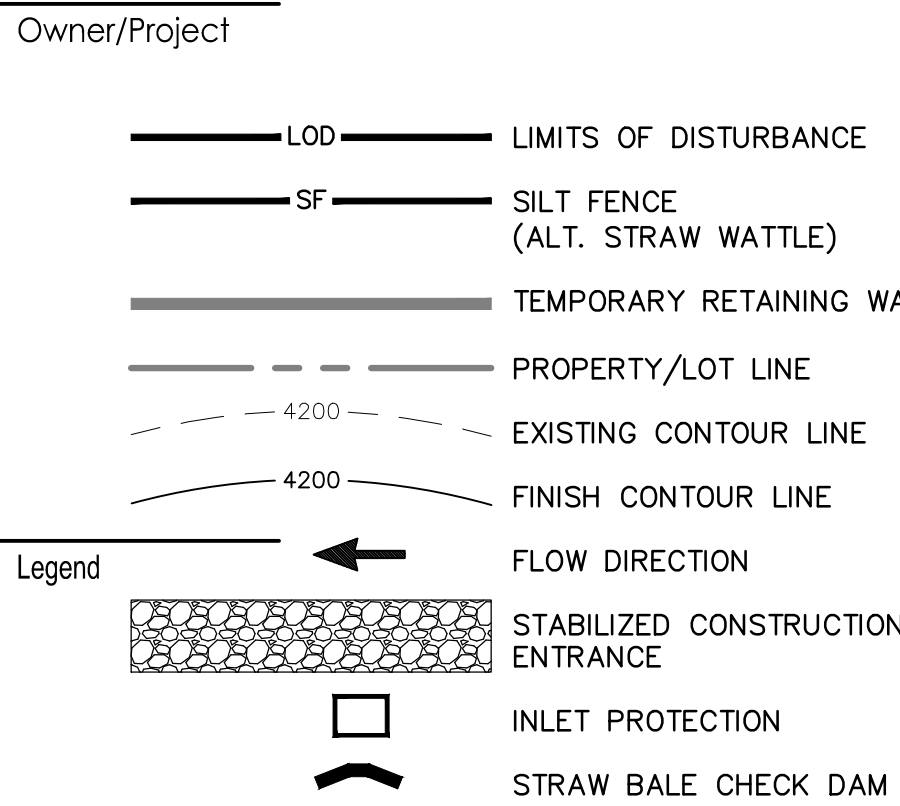

1. TEMPORARY RETAINING WALLS SHALL BE CONSTRUCTED ACROSS FUTURE DRIVEWAYS. FUTURE DRIVEWAYS AND FUTURE RETAINING WALLS N.I.C.
2. ALL UTILITY WORK IS FUTURE AND SUBJECT TO REVIEW AND REVISION.

| Revision | By                     | Appd. | YY.MM.DD     |          |
|----------|------------------------|-------|--------------|----------|
| 4        | NEW DRAINAGE CALCS     | CB    | SB 14.04.20  |          |
| 3        | PARK CITY RE-SUBMITTAL | BD    | PMD 15.03.27 |          |
| 2        | PARK CITY RE-SUBMITTAL | CB    | PMD 15.03.16 |          |
| 1        | PARK CITY SUBMITTAL    | CB    | JRJ 15.01.23 |          |
| Issued   |                        | By    | Appd.        | YY.MM.DD |

File Name: C-500 ec.dwg  
SDJ JRJ EKW 14.12.19  
Dwn. Chkd. Dsgn. YY.MM.DD

Permit-Seal

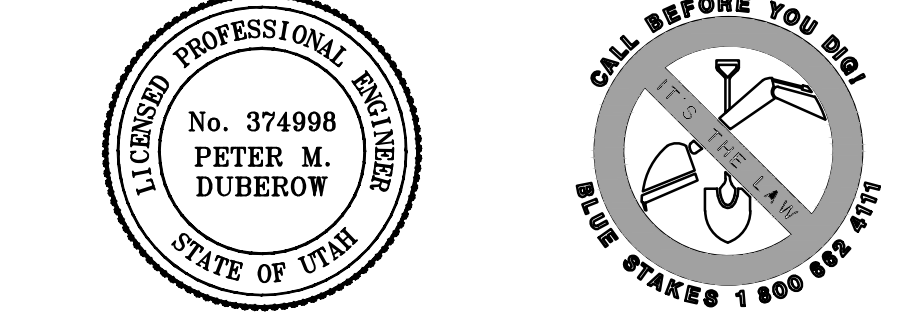

Client/Project  
KING DEVELOPMENT L.L.C.  
PO BOX 244  
PARK CITY, UTAH 84060  
ALICE CLAIM  
Park City, Utah

Title  
**EROSION CONTROL PLAN**

Project No. 205303057  
Scale 1"=40'  
Drawing No. Sheet  
Revision

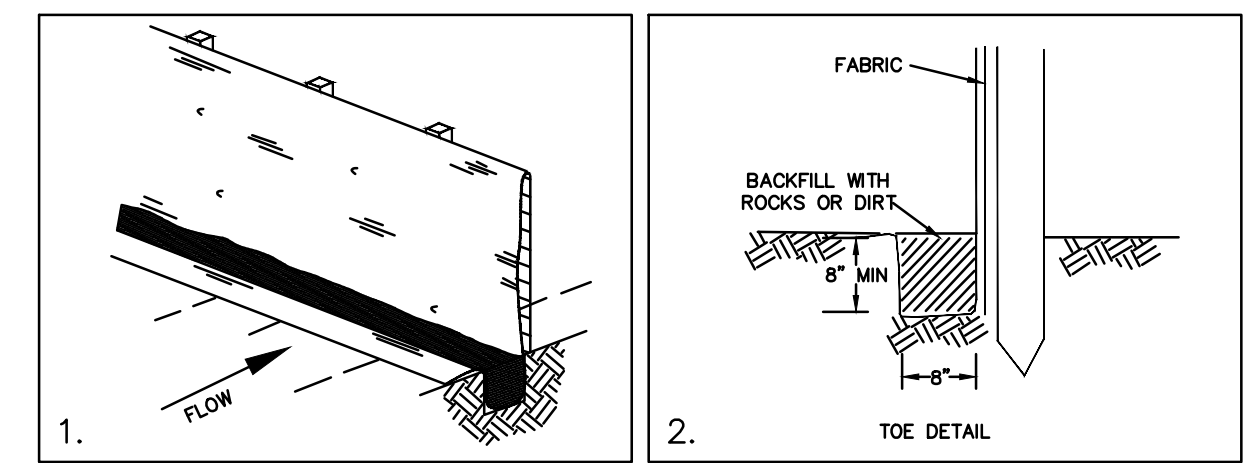

**SILT FENCE**  
SILT FENCE MAY BE INSTALLED FOR PERIMETER CONTROL. A MINIMUM 20-FOOT VEGETATED BUFFER MAY ALSO BE SUBSTITUTED FOR PERIMETER CONTROL. (PRESERVATION OF EXISTING VEGETATION).

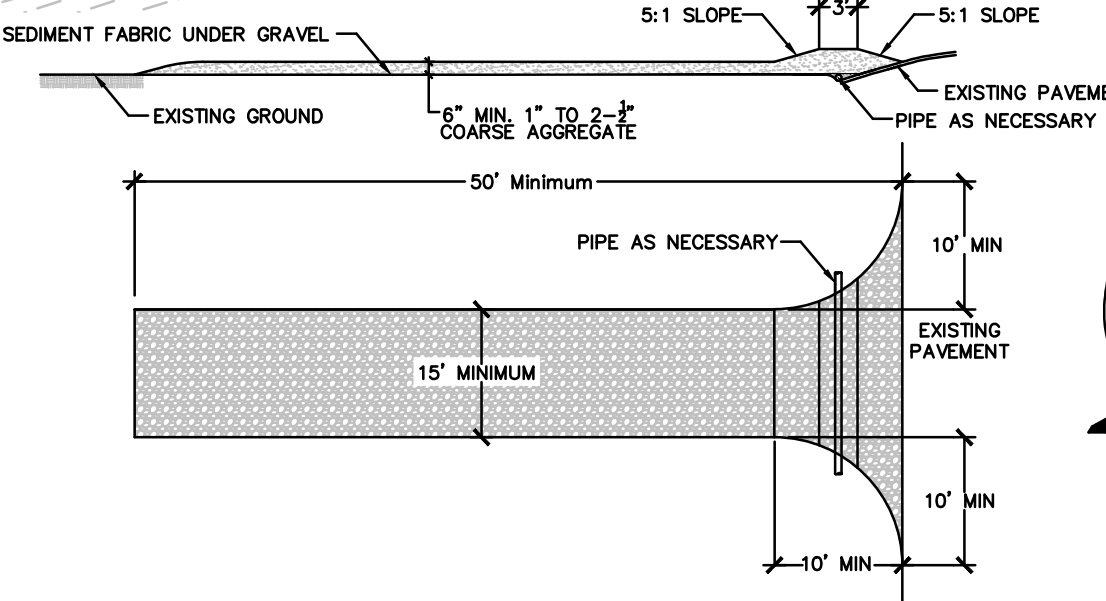

**STABILIZED CONSTRUCTION ENTRANCE**  
STABILIZED CONSTRUCTION ENTRANCE SHALL BE MAINTAINED UNTIL SUCH TIME PARK IS DEVELOPED.

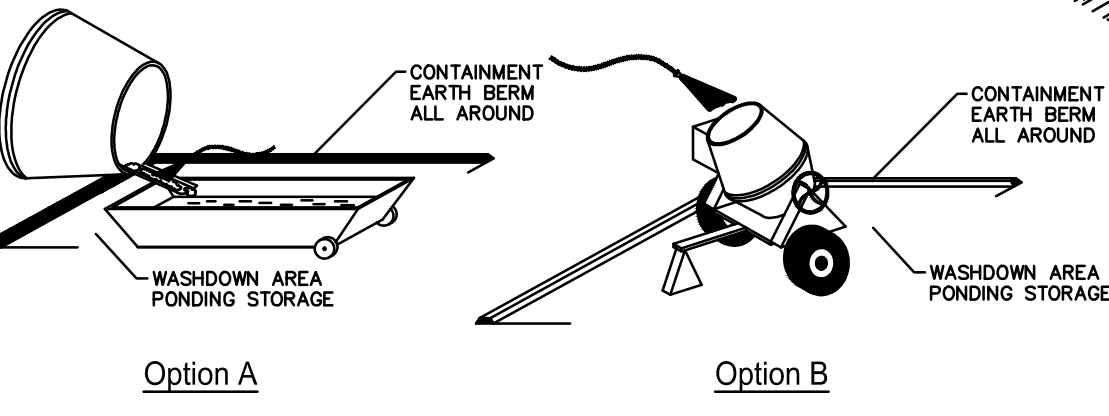

**CONCRETE WASTE MANAGEMENT**

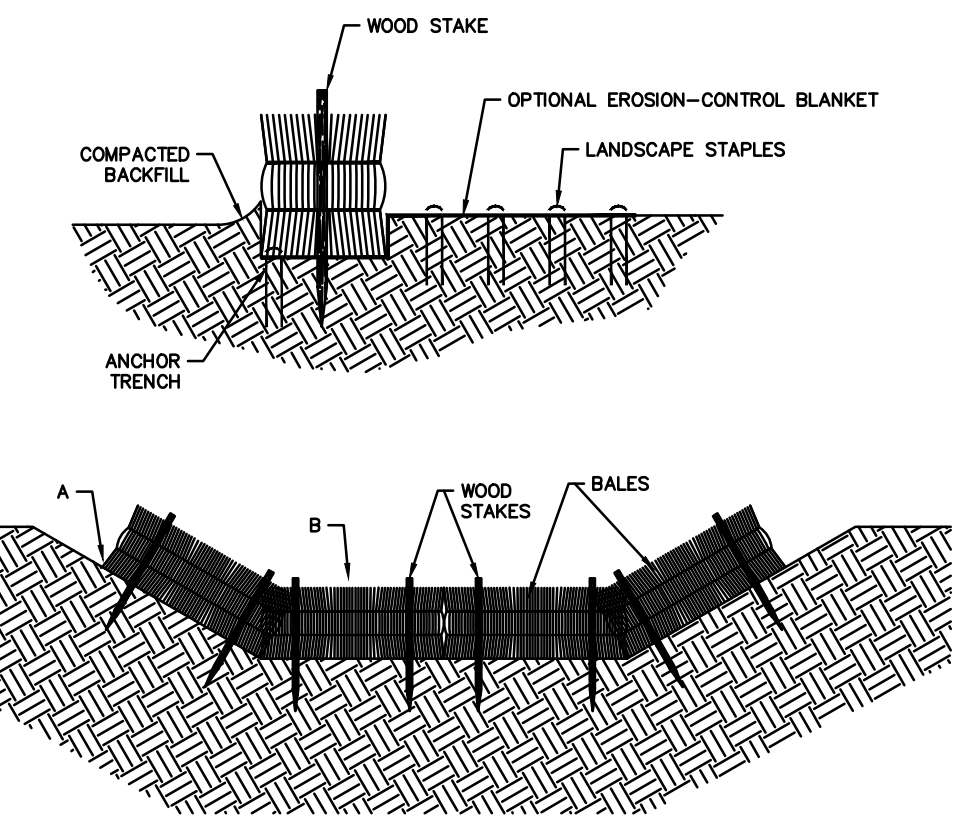

THE FOLLOWING TABLE PROVIDES CHECK DAM SPACING FOR A GIVEN DITCH GRADE.

| (A) DITCH % | (B) CHECK DAM SPACING (FEET) |
|-------------|------------------------------|
| 1.0         | 200                          |
| 2.0         | 100                          |
| 3.0         | 66                           |
| 4.0         | 50                           |
| 5.0         | 40                           |
| 6.0         | 33                           |

**STRAW BALE CHECK DAM**

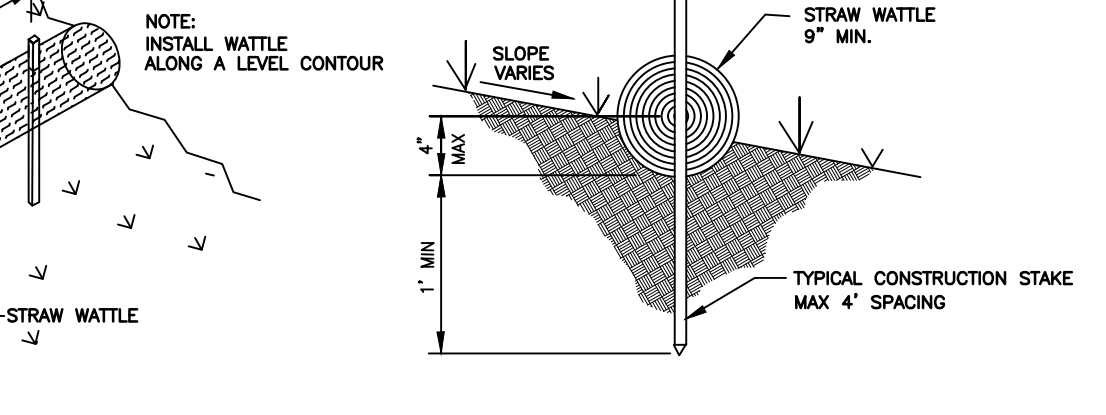

**STRAW WATTLE**

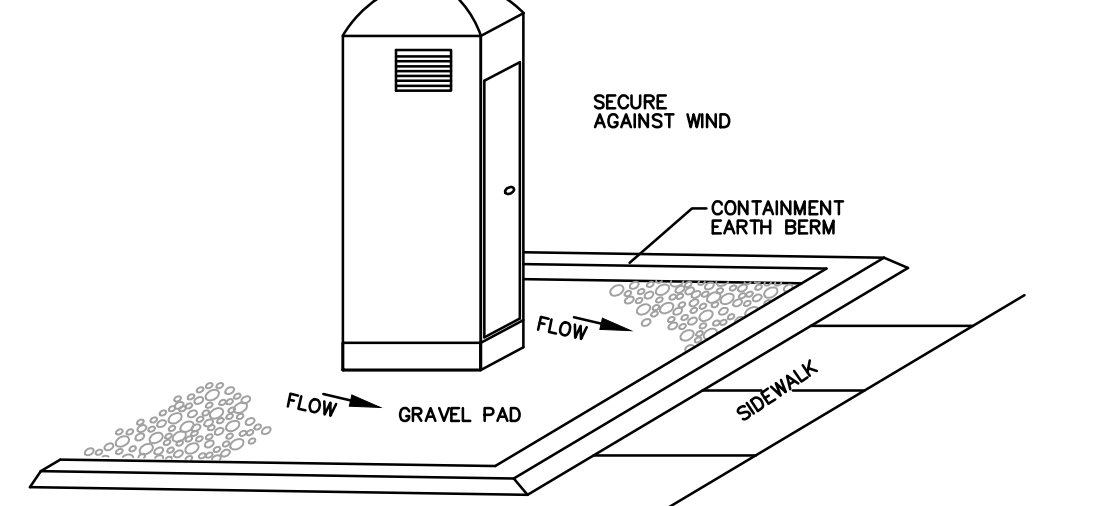

**PORTABLE TOILET**  
PORTABLE TOILETS TO BE INSTALLED DURING HOMEBUILDING PHASE.

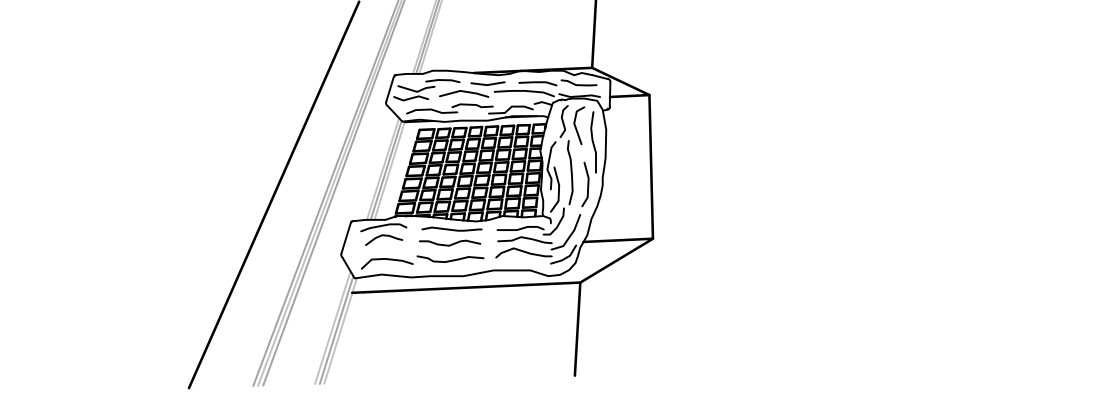

**INLET PROTECTION - WATTLE**  
WATTLE MAY BE GRAVEL FILLED OR STRAW FILLED. INSTALL WHEN CONSTRUCTION OF CURB AND GUTTER AND ROADWAYS IS COMPLETE.